

GOALS—BICYCLE STATION

- PROVIDE 3 TIERS OF STORAGE: 10-20-30
- TIER SELECTION DRIVEN BY EXISTING SITE CONDITIONS
- CREATE CONSISTENT STATION THEMES
- CONNECT TO OTHER TRANSPORTATION NETWORKS
- FUNCTIONS AS SAFE, COMFORTABLE, ACCESSIBLE & SOCIAL
- CREATE MODULAR STATIONS WITH FLEXIBLE DESIGN ELEMENTS
- SUPPORT ALTERNATIVE MODES OF TRANSPORTATION

TIER 1

SITES: 1, 3, 10, 14, 16, 17, 20, 21, 22, 23

BICYCLE STATION

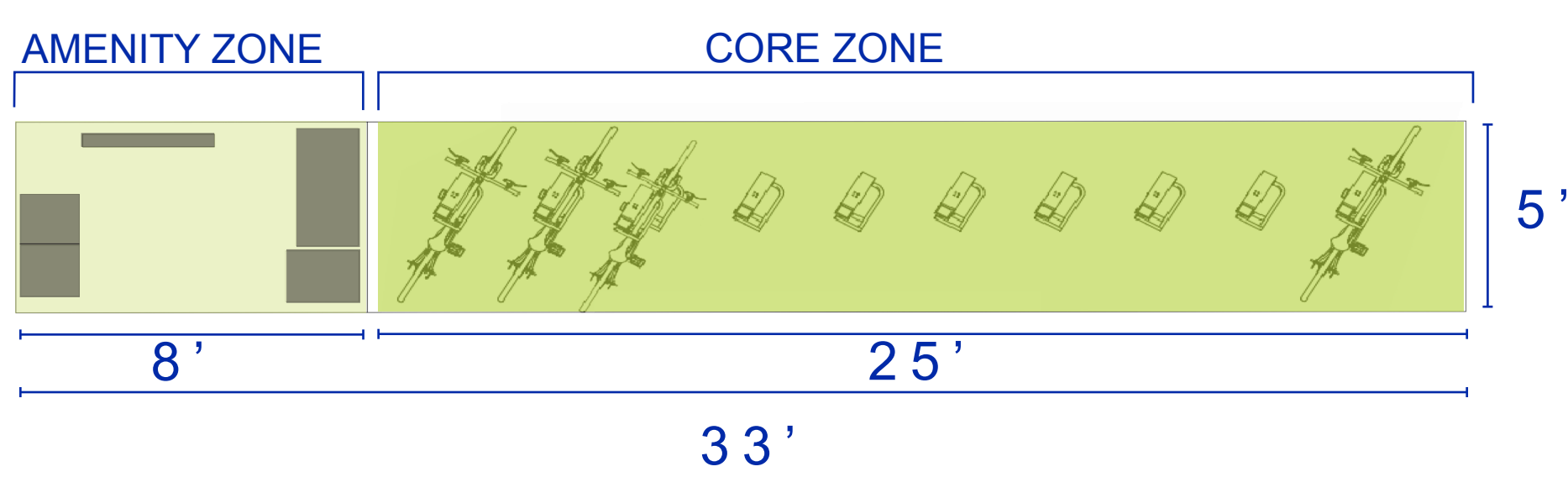

TIER 2

SITES: 2, 4, 6, 7, 9, 11, 12, 15, 18, 25, 26, 27

BICYCLE STATION

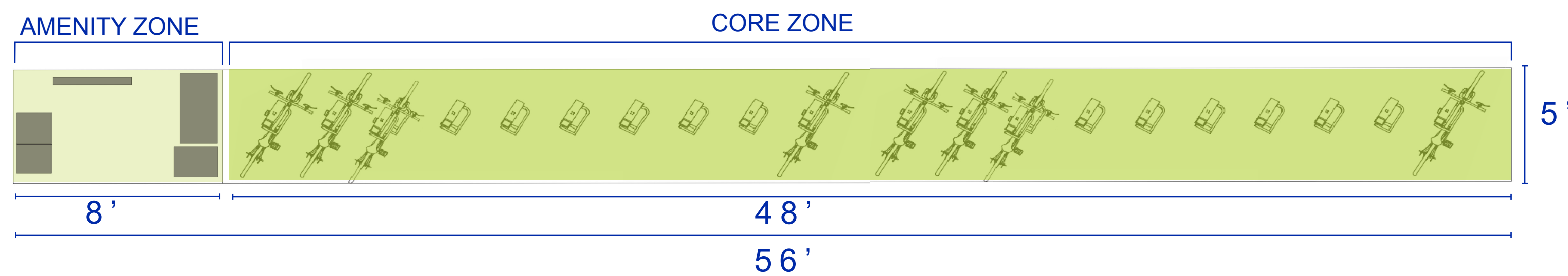

TIER 3

SITES 5, 8, 13, 19, 24

BICYCLE STATION

