

City of Scottsdale

2003



**SUPPLEMENTAL
STANDARD DETAILS
FOR
PUBLIC WORKS
CONSTRUCTION**

REVISED 8/11/03

**2100 Series
General Information**

- 2124 Accessible Signage
- 2131 Sign Post Installation
- 2132 Raised Pavement Marker Layout
- 2133 Median Nose Signing - Type A & B
- 2134-1 Street Name Signs - Type A
- 2134-2 Street Name Signs - Type B
- 2134-3 Street Name Signs - 18" And 24" Metro
- 2135 Street Name Sign Installation
- 2136 Advance Street Name Signs
- 2137 Loop Detectors
- 2138 Signal Pole Drilling Detail
- 2139 Traffic Signal Controller Cabinet Extender
- 2140 Model 330 Input Rack Wiring Instructions
- 2141 Tape Color Codes for Traffic Signal Wiring
- 2146-1 Refuse Enclosure
- 2146-2 Refuse Enclosure With Grease Containment Area
- 2147-1 Double Refuse Enclosure
- 2147-2 Double Refuse Enclosure With Grease Containment Area
- 2165-1 16' Sliding Gate & Hinged Door
- 2165-2 16' Sliding Gate

**2200 Series
Street Information**

- 2200 * Pavement Replacement
- 2201 Trench Bedding & Backfill
- 2202 Trench Plating
- 2207 Residential Unpaved Road
- 2210 Grading Behind The Curb

**2200 Series
Street Information Cont'd**

- 2220 Curb And Gutter - Types "A" & "B"
- 2221 Curb And Gutter - Types "M" & "W"
- 2225 Median Nose & Reverse Curve Details
- 2226 16' Median Nose Details
- 2228 Cut-Off Wall
- 2230 Sidewalk Cut-Off For Utility Poles
- 2232 Sidewalk Ramp Retrofit
- 2238 Concrete Paver Crosswalk
- 2239 Median Concrete Pavers
- 2240 6' Valley Gutter & Apron
- 2250 Driveway Entrances
- 2255 Residential Driveways
- 2256 Commercial/Industrial Driveways-Type CL
- 2257 Commercial/Industrial Driveways-Type CH
- 2258 Commercial/Industrial Driveways-Type CI
- 2266-1 Mid-Block Bus Bay - Type "A"
- 2266-2 Mid-Block Bus Bay - Type "B"
- 2267 Far Side Bus Bay
- 2268 Base Slab And Foundations For Bus Stop Bench And Receptacles
- 2269 Transit Shelter Pad
- 2270 Frame & Cover Grade Adjustment
- 2281 Multi-Use Path Crossing Sign
- 2282 Multi-Use Path Striping And Signing
- 2283 Multi-Use Path Details
- 2284 Multi-Use Path Wet Crossing Sign
- 2285 Double Bicycle Rack

**2300 Series
Water Information**

- 2305-1 Butterfly Valve Operator Manhole
- 2305-2 Butterfly Valve Operator Manhole
- 2315 Nonpotable Water Valve Box & Cover
- 2330 * Water Service Line Connection
- 2332 Chlorine Injection Tap
- 2333 Tap For Future Chlorine Injection
- 2342-1 Pressure Reducing Valve
- 2342-2 Pressure Reducing Valve
- 2345-1 3", 4", 6" Water Meter
- 2345-2 3", 4", 6" Water Meter
- 2346 Temporary Construction Meter
- 2348 Air / Vacuum Release Valve
- 2349 Water Quality Sampling Station
- 2351 Double Check Valve Backflow Prevention Assembly For Assemblies 3" Thru 10"
- 2352 Double Check Valve Backflow Prevention Assembly For Assemblies 3/4" Thru 2 1/2"
- 2353 Reduced Pressure Principle Backflow Prevention Assembly For Assemblies 3" Thru 10"
- 2354 Reduced Pressure Principle Backflow Prevention Assembly For Assemblies 3/4" Thru 2 1/2"
- 2355 Pressure Vacuum Breaker Assembly For Assemblies 1/2" Thru 2"
- 2356 Guard Posts For Backflow Prevention Assemblies

NOTE: * - Indicates New Or Revised Details For 2003 Supplement.

DETAIL NO.
2100-1

**City of Scottsdale
Standard Details**

INDEX

DETAIL NO.
2100-1

2300 Series
Water Information Cont'd

- 2357 Fill Pipe Details For Portable Tanks w/
Air Gap Separation
- 2358 Backflow Prevention For Portable Tanks
With No Air Gap Separation
- 2359 "N" Shaped Double Check Valve
Backflow Prevention Assembly For
Assemblies 3" Thru 10"
- 2360 "N" Shaped Reduced Pressure Principle
Backflow Prevention Assembly For
Assemblies 3" Thru 10"
- 2361 Fire Hydrant Bypass Assembly
- 2362 1-1/2" - 2" Fire Line Connection
- 2363 Pavement Markers For Fire Hydrants
- 2364 Fire And Emergency Access And
Delineation
- 2365 Fire Lane Sign
- 2366 * Concrete Collar For Fire Hydrants
- 2370 Vertical Realignment Of Water Mains
- 2372 Minimum Utility Separation
Requirements
- 2397 Electronic Ballmarker Placement
- 2398 * Antenna Mast Detail

2400 Series
Sanitary Sewer Information

- 2402 Force Main Discharge Manhole
- 2403 2-Way F.M. Cleanout, 3" & Above
- 2404 F.M. Cleanout W/ Sewer Release A.V.
- 2405 Sewer Air Release Valve
- 2420 Water Tight Concrete Sewer Manhole
- 2460 Sewer Building Connection
- 2460 Monitoring/Sampling Vault

2500 Series
Irrigation & Storm
Drain Information

- 2508 Handrail Detail
- 2515-1 Wall Opening & Erosion Protection -
Type 1
- 2515-2 Drainage Grate At Block Wall
- 2515-3 Wall Opening Erosion Protection -
Type 2
- 2535 Catch Basin Grates
- 2554 Concrete Invert Paving For Corrugated
Metal Pipe And Pipe Arch
- 2562-1 Storm Sewer Outfall Access Barrier
- 2562-2 Barrier Specifications Schedule

2600 Series
Landscape Information

- 2600-1 Minimum Tree Size Requirements
- 2600-2 Minimum Tree Size Requirements
- 2600-3 Minimum Tree Size Requirements
- 2610 * Typical Wire Connection
- 2620-1 Landscape Details
- 2620-2 Landscape Details

2600 Series
Landscape Information

- 2620-3 Landscape Details
- 2631 Irrinet Pedestal Mounted Controller
- 2632 Scorpio Pedestal Mounted Controller
- 2633 * Scorpio Wall Mounted Controller
- 2634 Irrinet Wall Mounted Controller
- 2635-1 Solar Controller
- 2635-2 Solar Controller & Backflow Enclosure
- 2636 Irrigation Push Button Control
- 2641-1 Single & Multi-Outlet Emitters
- 2641-2 Irrigation Emitter Layout
- 2642 * Irrigation Trenching
- 2643 Irrigation Thrust Block
- 2644 Rotor Sprinkler Assembly
- 2645 Pop-Up Sprinkler Assembly
- 2646 Shrub Pop-Up Sprinkler Assembly
- 2647 * Drip Filter & Pressure Regulator
- 2648 Emitter Flush Cap Assembly
- 2649 * Quick Coupler Assembly
- 2650 * 1-1/2" & Smaller Mainline Ball Valve
- 2651 * 2" & Larger Mainline Isolation Valve
- 2652 * 2" Or Smaller Master Valve/Flow Meter
- 2653 * 3" Or Larger Master Valve/Flow Meter
- 2654 * Remote Control Valve Assembly
- 2680-1 Trail Access Gates
- 2680-2 Trail Access Gates
- 2681 Trail Water Bars
- 2682 Trail Safety Barriers
- 2683 Trail Signs

NOTE: * - Indicates New Or Revised
Details For 2003 Supplement.

DETAIL NO.
2100-2

City of Scottsdale
Standard Details

INDEX

DETAIL NO.
2100-2

REVISED 2/26/01

NOTE:

Lettering shall be FHWA Series "B" alphabet, or Helvetica Med. Cond.

MOUNTING OPTIONS (SEE PLANS)

- A) Flexible P.E. Post With Surface Mount Base – Epoxy To Pavement Surface
- B) Perforated Galvanized Tubing Per COS Detail 2131. Install In Landscape Areas Only.
- C) Surface Mount To Structure
- D) Mount As Detailed On Plans

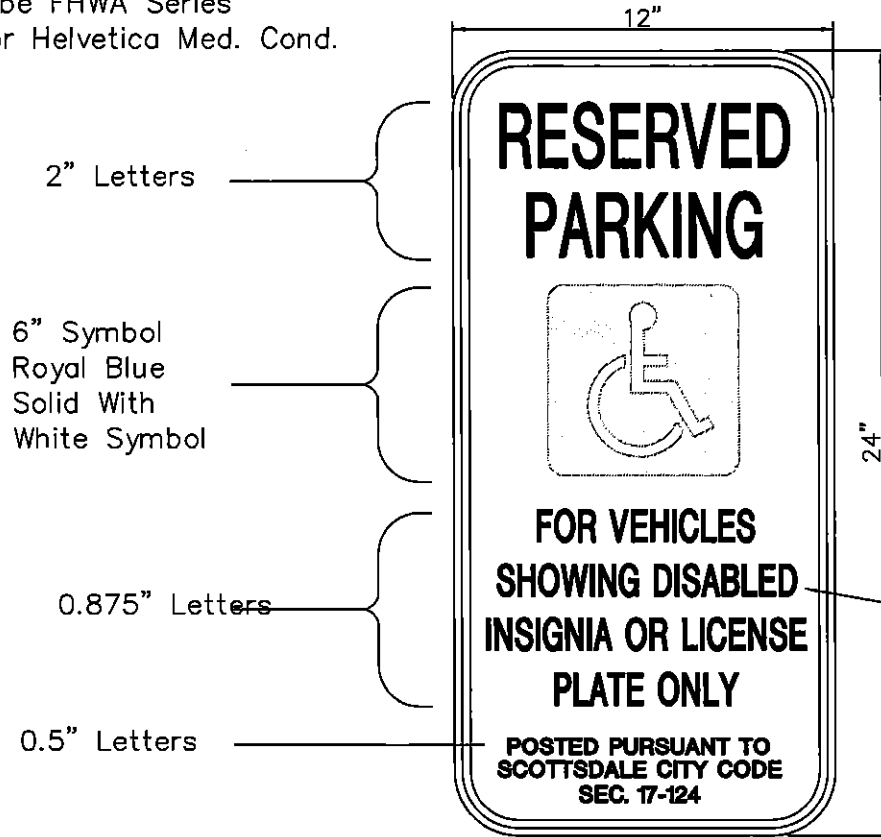

Green Borders and Text, and Blue Symbol on White Retroreflective Background (Typ.)
 Background: Super Engineer Grade Or High Intensity Sheeting
 Copy: Same As Above
 Substrate: 0.080 Gauge Treated Aluminum

Bottom Of Sign Shall Be Not Less Than 3 Feet Nor More Than 6 Feet Above Finish Surface

ACCESSIBLE SIGNAGE

One Sign At Each Accessible Parking Stall

REVISED 1/3/94

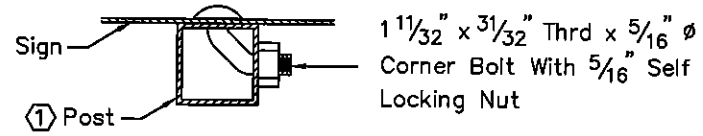
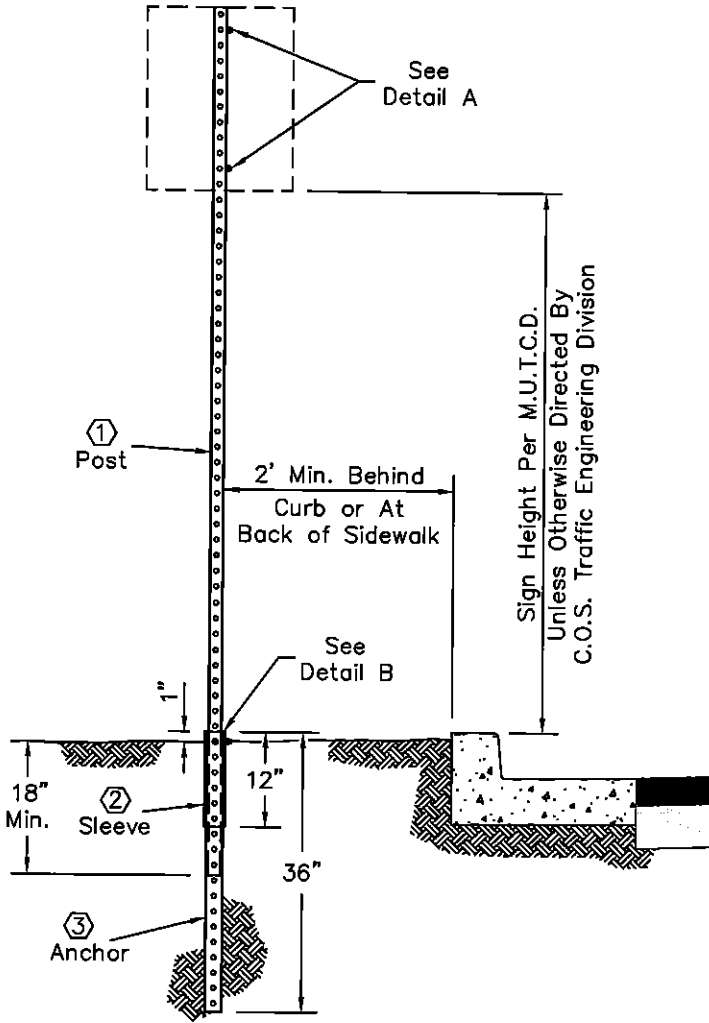

Detail A
Sign Mounting

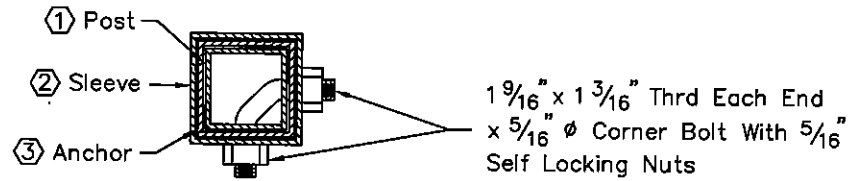

Detail B
Anchor Assembly

Legend

- ① Post - 1-3/4" x 1-3/4" Square Perforated 0.105" Galvanized Steel Tubing (Green Finish)
- ② Sleeve - 2-1/4" x 2-1/4" x 12", Square Perforated 0.105 Galvanized Steel Tubing (Green Finish)
- ③ Anchor - 2" x 2" x 36", Square Perforated 0.105" Galvanized Steel Tubing (Green Finish)

NOTE:

1. Sign Post, Sleeve And Anchor Per COS Supplemental Spec. Section 402.3

DETAIL NO. 2131 City of Scottsdale Standard Details APPROVED BY: _____

SIGN POST INSTALLATION

DETAIL NO. 2131

REVISED 5/7/07

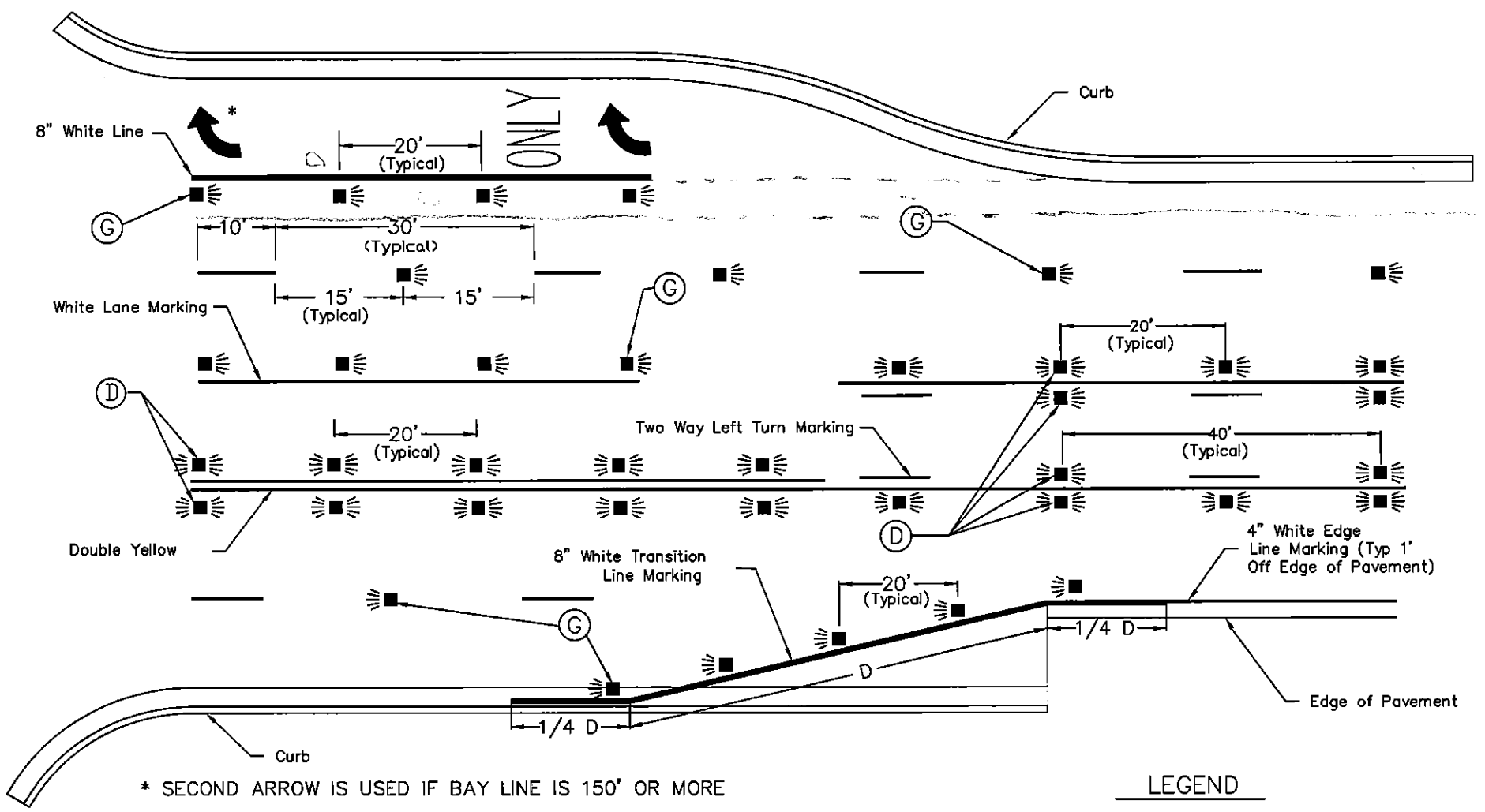

* SECOND ARROW IS USED IF BAY LINE IS 150' OR MORE

LEGEND

- ⊙ - TYPE "G" WHITE, ONE WAY REFLECTIVE
- ⊙ - TYPE "D" YELLOW, TWO WAY REFLECTIVE
- ■ ≡
- ≡ ■ ≡

REFERENCE ADOT STD DRAWINGS 4-M-2.03 AND 4-M-2.04
 SEE STANDARD DETAIL 2363 FOR FIRE HYDRANT MARKERS

DETAIL NO. 2132 City of Scottsdale
 Standard Details

RAISED PAVEMENT MARKER LAYOUT

DETAIL NO. 2132

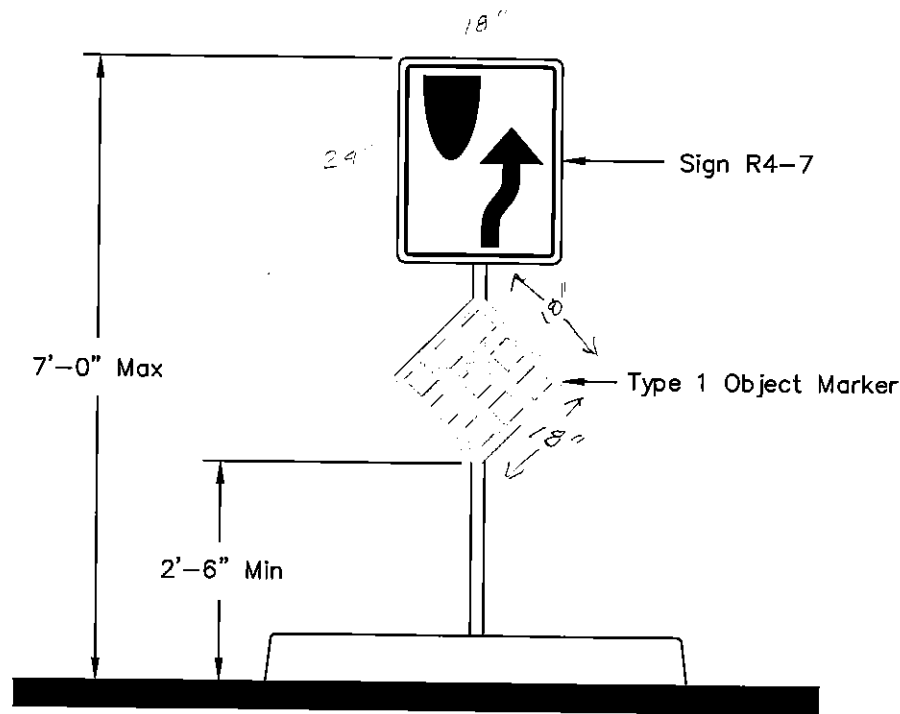

TYPE "A"

(AT SIGNALIZED INTERSECTIONS
OR AS SHOWN ON PLANS AND FIRST &
LAST NOSE ON A STRING OF MEDIANS)

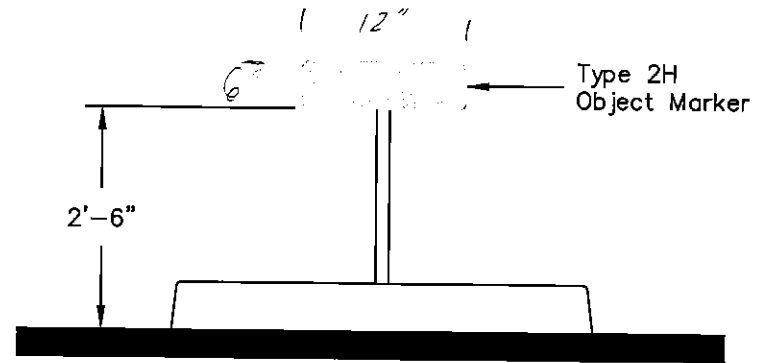

TYPE "B"
(ALL OTHER MEDIANS)

NOTES:

1. See COS Std Det 2225 Or 2226
For Typical Location.
2. Sign Posts Per COS Std Det 2131.

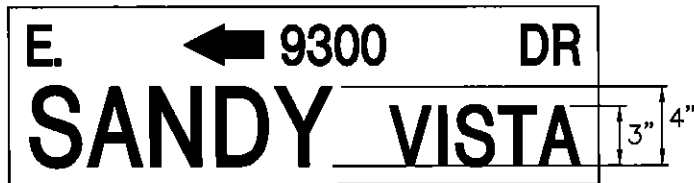
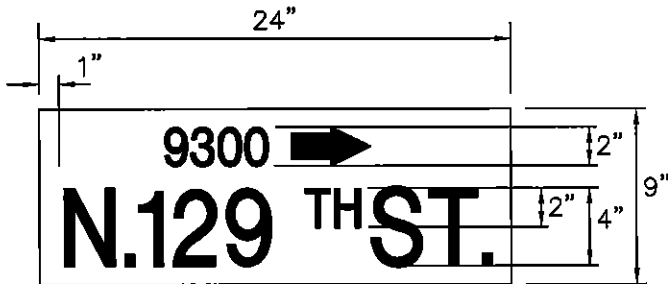

TYPE A SIGNS

Type IIA Super Engineering Grade
Green/White (2 Sides)

Blank Sizes: 9"x 24", 9"x 30",
9"x 36", 9"x 42"

Intended Usage: Type "A" Street Name Signs shall be used in residential areas where Residential Streets intersect with Local Collector Streets. See the COS General Plan for Street Designations.

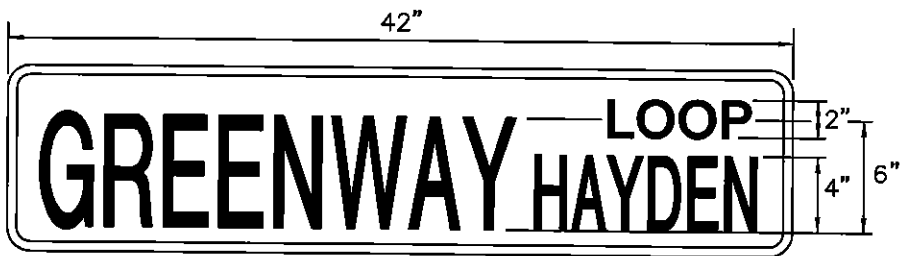
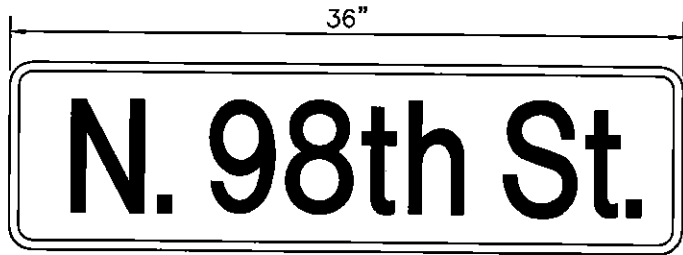

TYPE B SIGNS

Type III High Intensity Grade
Green/White (2 Sides)

Blank Sizes: 10"x 36", 10"x 42"

Intended Usage: Type "B" Street Name Signs shall be used where a Residential Street or a Local Collector Street intersects with a street with a classification of Major Collector or larger. See the COS General Plan for Street Designations.

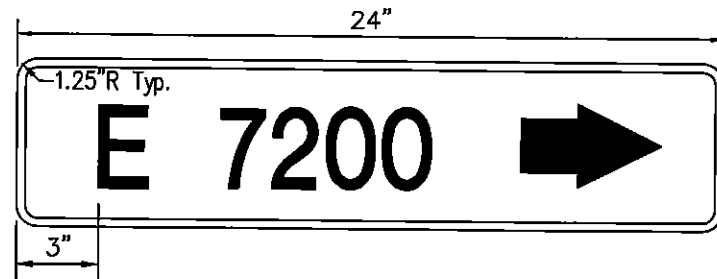
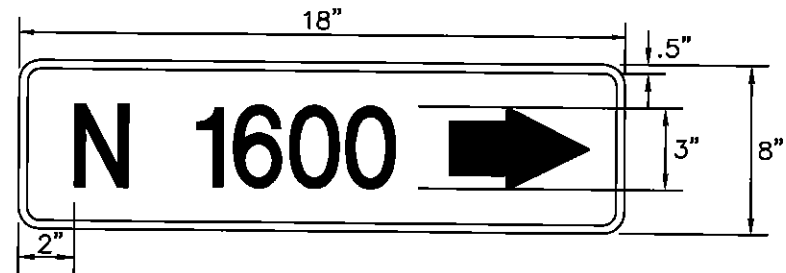

TYPE B BLOCK NUMBERS

Type III High Intensity Grade
Green/White (1 Side)

Blank Sizes: 8"x 18", 8"x 24"

Type "B" Block Numbers to be mounted with Type "B" Street Name Signs.

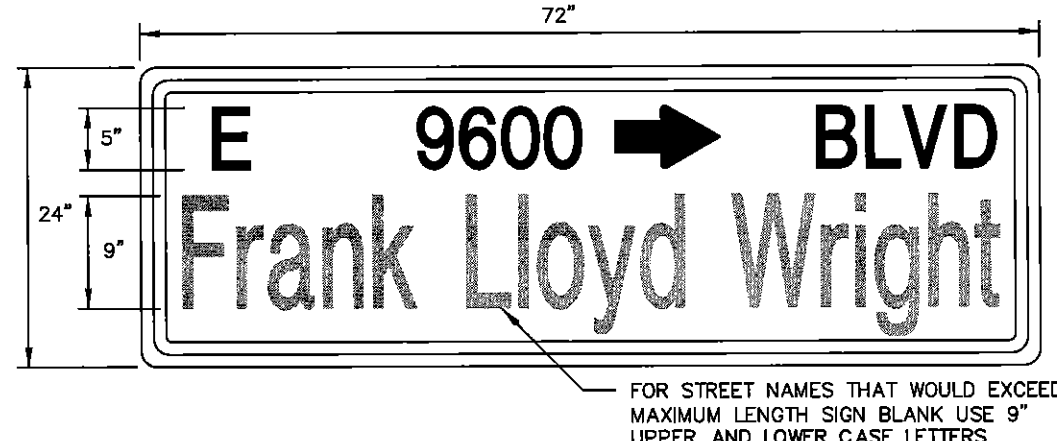
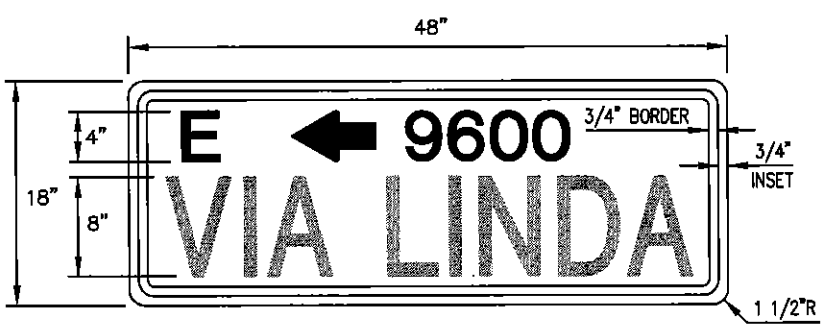
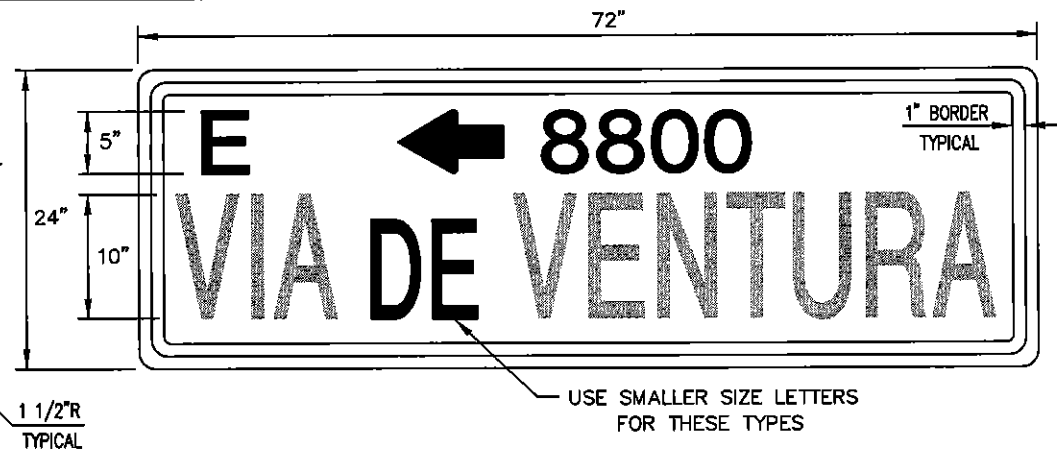
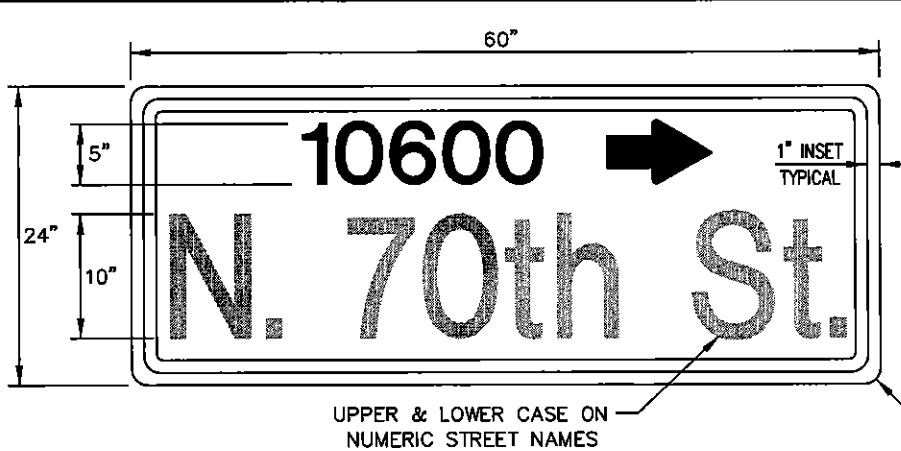

18" METRO SIGNS

Diamond Grade Intensity – Green/White (1 Side)
 Typestyle = Highway Gothic, Modify C or D
 Blank Sizes: 18"x 48", 18"x 60", 18" x 72"
 Intended Usage: 18" Metro Street Name Signs shall be used on minor roads with a speed limit of 35MPH or lower. See the COS General Plan for Street Designations.

24" METRO SIGNS

Diamond Grade Intensity – Green/White (1 Side)
 Typestyle = Highway Gothic, Modify C or D
 Blank Sizes: 24"x 60", 24"x 72", 24" x 84"
 Intended Usage: 24" Metro Street Name Signs shall be used on major roads with a speed limit of 35MPH or higher. See the COS General Plan for Street Designations.

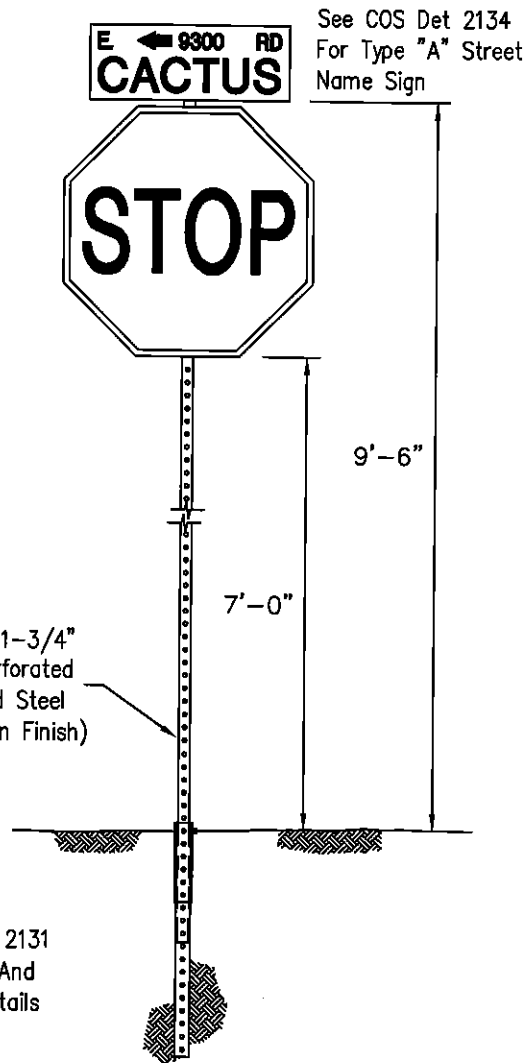

NOTES:

Street name sign and stop sign mounting height shall be measured from adjacent grade of sidewalk, top of curb or top of nearest pavement.

When no stop sign is required the street name sign is mounted at 9 feet 6 inches.

When two street name signs are mounted one on top of the other, the height is measured to the bottom sign.

DETAIL NO.
2135

City of Scottsdale
Standard Details

STREET NAME SIGN INSTALLATION

DETAIL NO.
2135

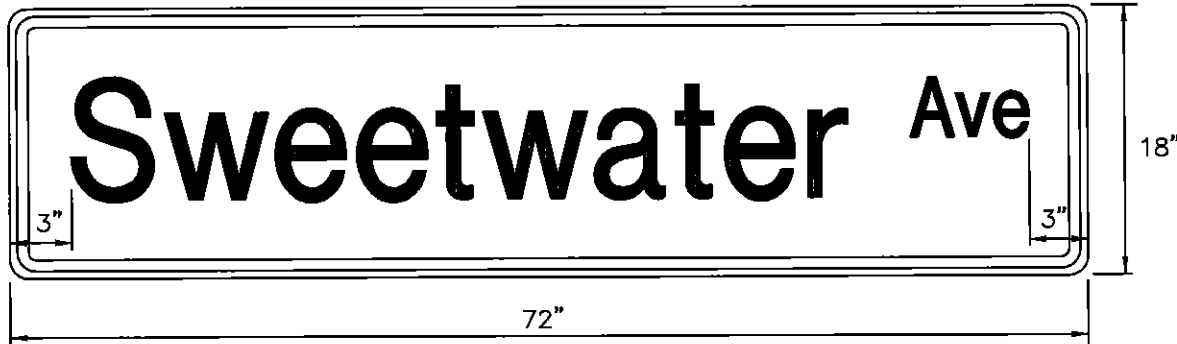
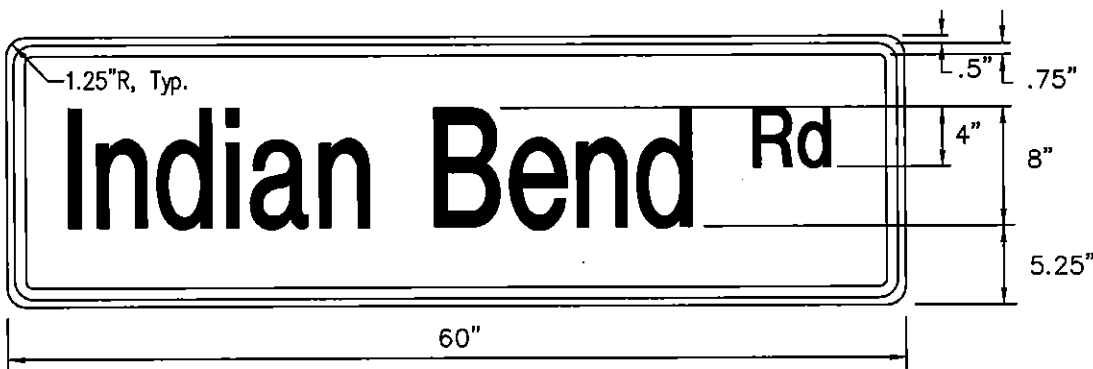

Type III High Intensity, Green/White (1 Side)
 Blank Sizes: 18"x 48", 18"x 60", 18"x 72"

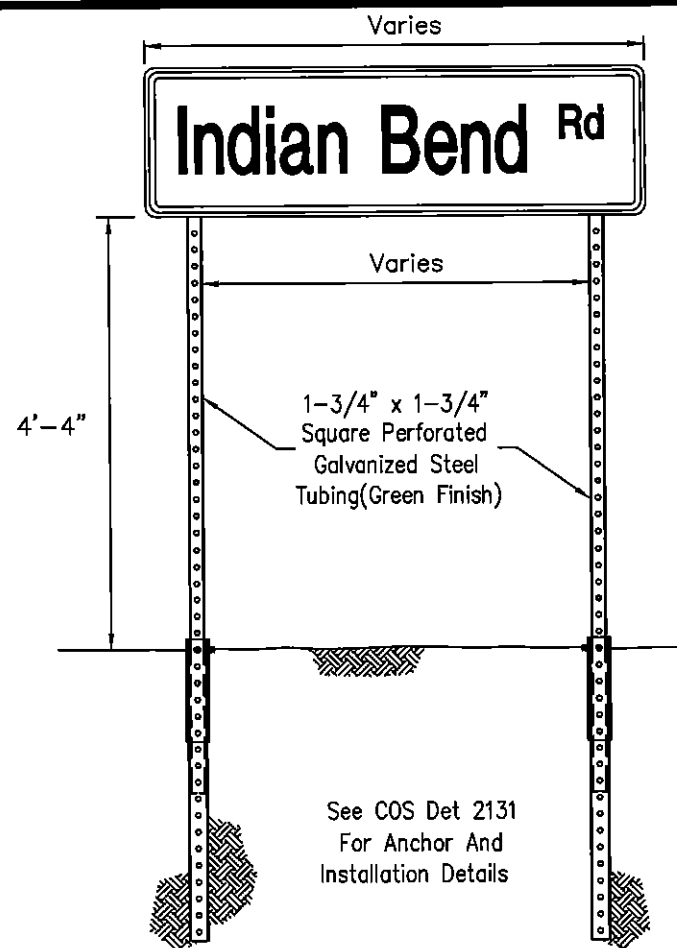

Intended Usage: To be used in advance of the specified street where an unsignalized collector street intersects a minor/major arterial or expressway. Location determined by multiplying the posted speed limit by 10. Sign is typically placed in a median when available, otherwise on the right hand side of the road.

DETAIL NO. **2136**
City of Scottsdale
Standard Details

ADVANCE STREET NAME SIGNS

DETAIL NO. **2136**

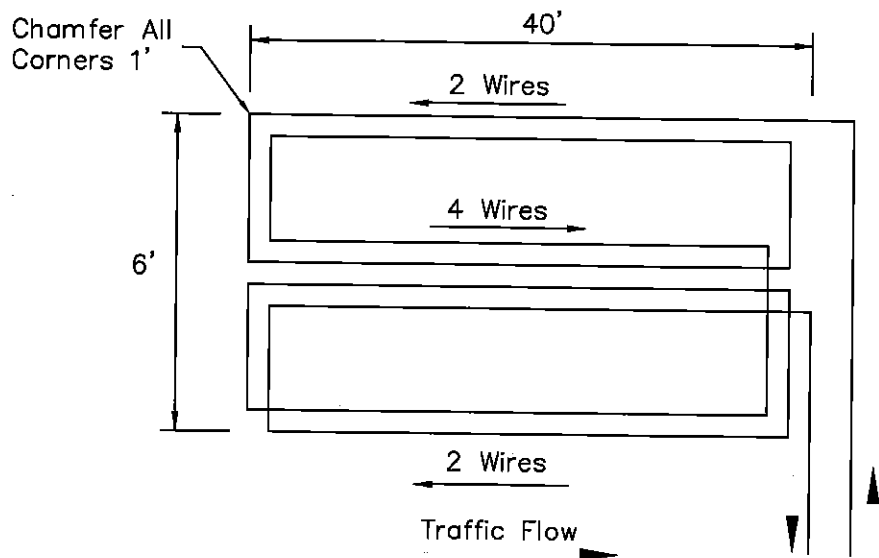

QUADRUPOLE LOOP DETECTOR
For Left Turn Lanes Only

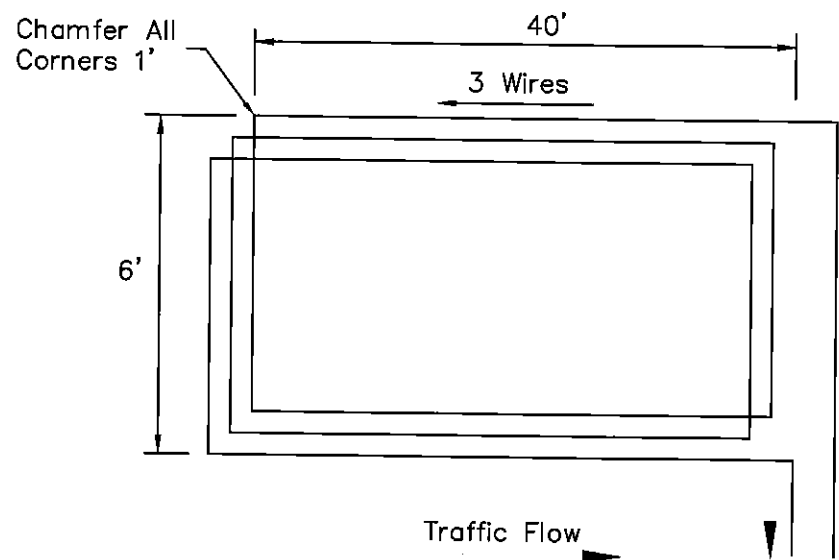

STANDARD LOOP DETECTOR

NOTES:

1. All loop detectors shall be wire-in-duct type wire. (Detect-a-Duct or approved equivalent, #14 stranded inside a 1/4" PVC tubing (IMSA 51-5).
2. All loop detectors shall be centered in the middle of the applicable traffic lane. Loop shall be sufficiently dimensioned on the plans. Loop detectors shall extend five feet into the crosswalk unless directed otherwise by the Traffic Engineering Department.
3. A rectangular loop with 3 turns (6 feet x 40 feet) shall be used for all through lanes.
4. A quadrupole loop with 2 outside turns and 4 inside turns (6 feet x 40 feet) shall be used in all exclusive left-turn lanes. (Wire in middle cut shall run the same direction).
5. Loop detectors shall not be installed in exclusive right turn lanes.
6. The location of permanent count detector loops shall be specified by the Traffic Engineering Department. Count detector loops shall consist of a minimum of 4 turns (6 feet x 6 feet).

7. Pre-formed loop detectors conforming to the latest ADOT specifications shall be used under decorative pavement, "pavers", concrete, or other "special" roadway surfaces, or as directed by the Traffic Engineering Department.
8. Lead-in cable between loop wire and controller shall be latest ADOT specification or approved equivalent (IMSA 50-2).
9. Loop lead-in and splices in pull box shall be twisted and soldered. Griggs Loop Detector Sealant, 3-M Loop Sealant, or approved equivalent shall be used.
10. Loops shall be installed prior to the installation of the final pavement lift (if part of a paving project).
11. Loops shall be inspected and tested prior to acceptance by the City.
12. See ADOT TS 7-1 for installation details.

DETAIL NO. **2137** **City of Scottsdale**
Standard Details

LOOP DETECTORS

DETAIL NO. **2137**

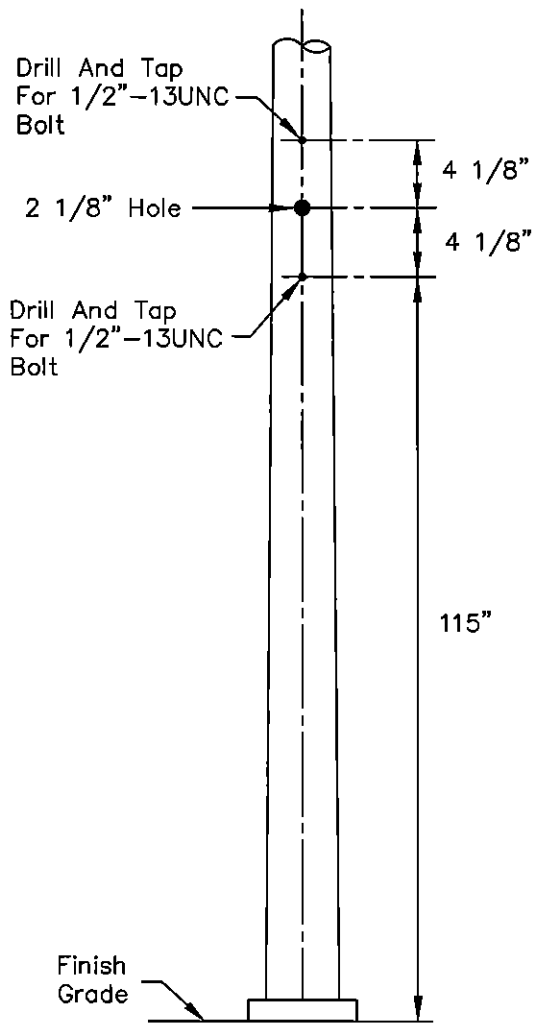

SIDE MOUNT DRILLING DETAIL

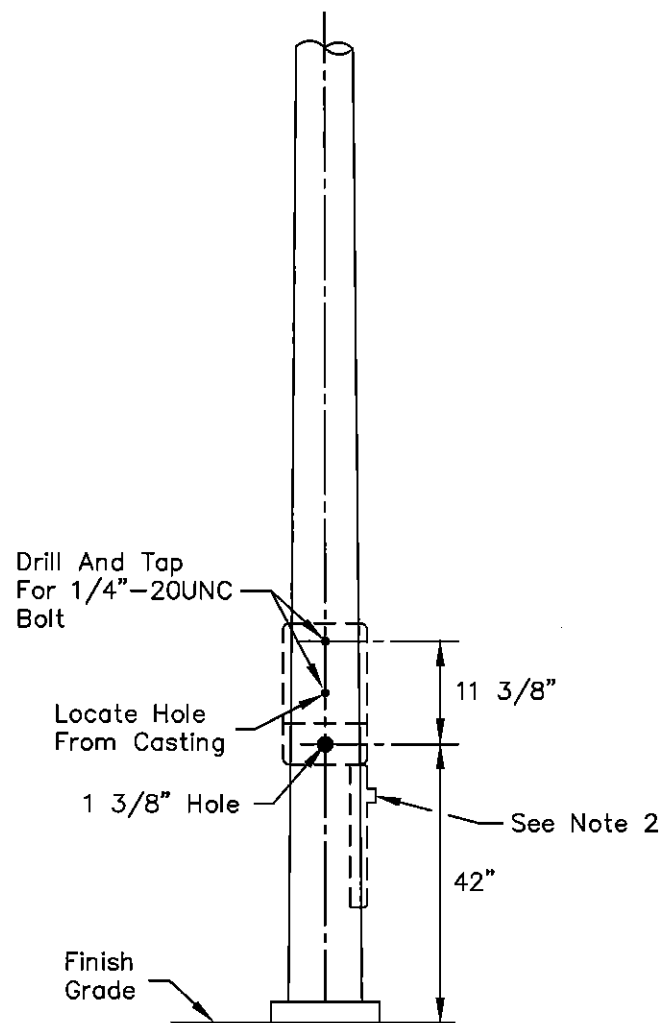

PUSH BUTTON DRILLING DETAIL

NOTES:

1. Drilling of pole to be oriented according to pole layout, or as directed by C.O.S. Engineer in the field.
2. When two pedestrian push button assemblies are mounted on a small diameter pole the lower assembly shall be positioned upside down so that the push button is at the top and the sign is below.
3. Top mounting holes to be field drilled in order to allow for manufacturing variations.
4. Push button shall be A.D.A large target style (ADOT Type I).

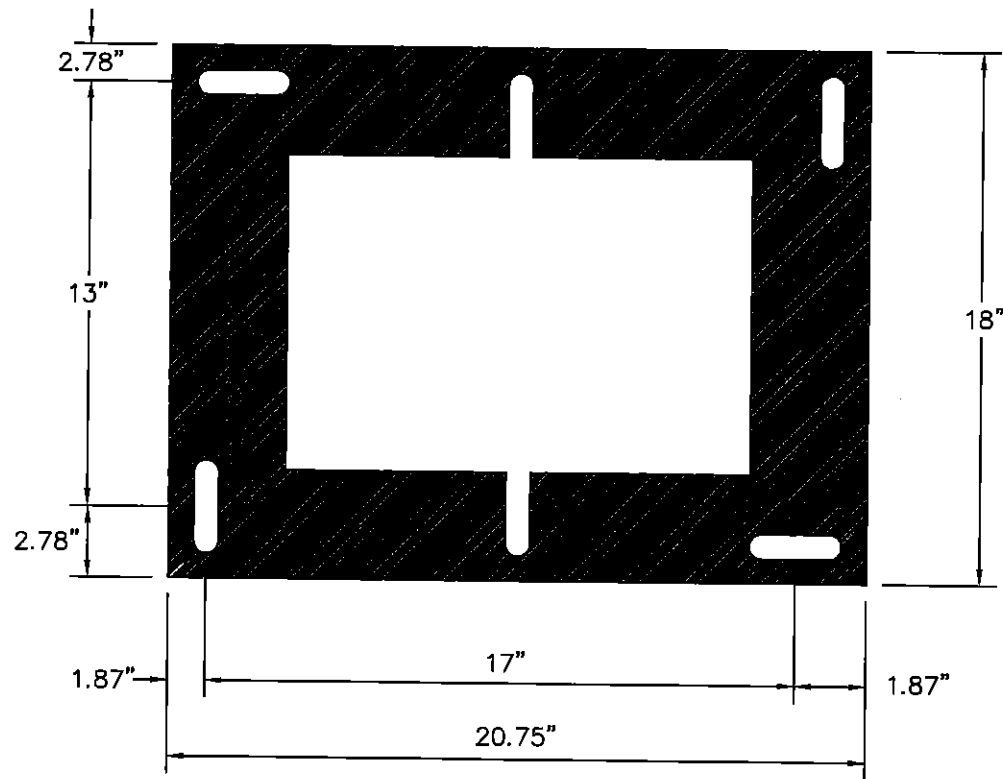

INSIDE VIEW OF BOTH
SIDES OF BASE EXTENDER

1. Model 330 cabinet base extenders will include cutouts that will accommodate replacement with all other Scottsdale 330 cabinets and model 336S. These base extenders are available from the cabinet manufacturer. All Scottsdale cabinets are foundation mounted.
2. Foundation must include a 4" x 24" x 24" concrete pad in front of the cabinet door.
3. The cabinet shall be mounted in such a way that when the technician has the door open and is facing the cabinet, he is also facing the intersection.
4. Cabinet base extender shall have a 12" x 12" removable access panel. Base extender shall be installed so that access panel is on door side of cabinet.

DETAIL NO.
2139

City of Scottsdale
Standard Details

TRAFFIC SIGNAL CONTROLLER CABINET BASE EXTENDER

DETAIL NO.
2139

LOOP AND PEDESTRIAN PUSH BUTTON INPUTS

Slot 1	Slot 2	Slot 3	Slot 4	Slot 5	Slot 6	Slot 7	Slot 8	Slot 9	Slot 10	Slot 11	Slot 12	Slot 13	Slot 14
1 AB Ph 1	3 AB Ph 2	5 AB Ph 3	7 AB Ph 4	9 AB Ph 5	11 AB Ph 6	13 AB Ph 7	15 AB Ph 8	17 AB 2 PPB	19 AB 4PPB	21 AB RRPre	23 AB AdvEn	25 AB EV A	27 AB Stop Time
2 AB Ph 1	4 AB Ph 2	6 AB Ph 3	8 AB Ph 4	10 AB Ph 5	12 AB Ph 6	14 AB Ph 7	16 AB Ph 8	18 AB 6 PPB	20 AB 8PPB	22AB Flash	24 AB Adv	26 AB EV B	28 AB 6 Call
Det Loops	Det Loops	Det Loops	Det Loops	Det Loops	Det Loops	Det Loops	Det Loops	Ped Push Buttons	Ped Push Buttons	-----	-----	Pre- Empt	Slot 14 ----- Slot 14

1. All Scottsdale model 330 cabinet input racks have 14 slots.
2. Slots 1–8 are for vehicle detector loops.
3. Phase 4 loops are terminated on slot 4 (7A&B and/or 8A&B).
4. Phase 4 pedestrian push button is terminated on 19A and ppb neutral on 19B.
5. 19B shall have a jumper to the neutral bar.
6. All two phase intersections are to be wired to phases 2 and 4.
7. Field output wiring for 2 phase signals shall be wired to 2R, 2Y, 2G and 4R, 4Y, 4G.
8. Ped field wiring shall be wired to 9R, 9G (Phase 2 Ped) and 10R, 10G (Phase 4 Ped).
9. Call COS Traffic Signals (480)312–5635 prior to wiring cabinet for instructions for intersections with more than 2 phases.

DETAIL NO.
2140

**City of Scottsdale
Standard Details**

MODEL 330 INPUT RACK WIRING INSTRUCTIONS

DETAIL NO.
2140

MAIN DIRECTIONS

**LEFT TURN DIRECTIONS
(Main Color + White)**

**RIGHT TURN DIRECTIONS
(Main Color + Black)**

**Color Of Wire For
Power/Neutrals/Pushbuttons**

Direction	Color
WB	Blue
EB	Green
NB	Red
SB	Yellow

Direction	Color
WBLT	Blue + White
EBLT	Green + White
NBLT	Red + White
SBLT	Yellow + White

Direction	Color
WBRT	Blue + Black
EBRT	Green + Black
NBRT	Red + Black
SBRT	Yellow + Black

Wire	Color
AC+ Power	Black
AC- (Neutral)	White
24V Pushbutton	Orange, Stranded

WBLT = West Bound Left Turn and shall be the phase for vehicles facing west and turning to south
 EBLT = East Bound Left Turn and shall be the phase for vehicles facing east and turning to north
 NBLT = North Bound Left Turn and shall be the phase for vehicles facing north and turning to west
 SBLT = South Bound Left Turn and shall be the phase for vehicles facing south and turning to east

WBRT = West Bound Right Turn and shall be the phase for vehicles facing west and turning to north
 EBRT = East Bound Right Turn and shall be the phase for vehicles facing east and turning to south
 NBRT = North Bound Right Turn and shall be the phase for vehicles facing north and turning to east
 SBRT = South Bound Right Turn and shall be the phase for vehicles facing south and turning to west

DETAIL NO.
2141

**City of Scottsdale
Standard Details**

TAPE COLOR CODES FOR TRAFFIC SIGNAL WIRING

DETAIL NO.
2141

REVISED 5/9/02

NOTE:

- 1. 1/2" Expansion Joint, ASTM D-1751 Per MAG Section 729.

30' x 14' x 6" Thick Concrete Approach Slab With Thickened Edges, Class "B" Concrete w/ 6"x 6", 1.4 x 1.4 WWF, On Compacted Subgrade. Approach Slab Shall Have A Constant Slope Which Matches The Enclosure Slab.

30' x 14' x 6" Thick Concrete Approach Slab With Thickened Edges, Class "B" Concrete w/ 6"x 6", 1.4 x 1.4 WWF, On Compacted Subgrade. Approach Slab Shall Have A Constant Slope Which Matches The Enclosure Slab.

* In locations where a 30' approach slab is not possible, approval from the City of Scottsdale Quality Compliance Division is required.

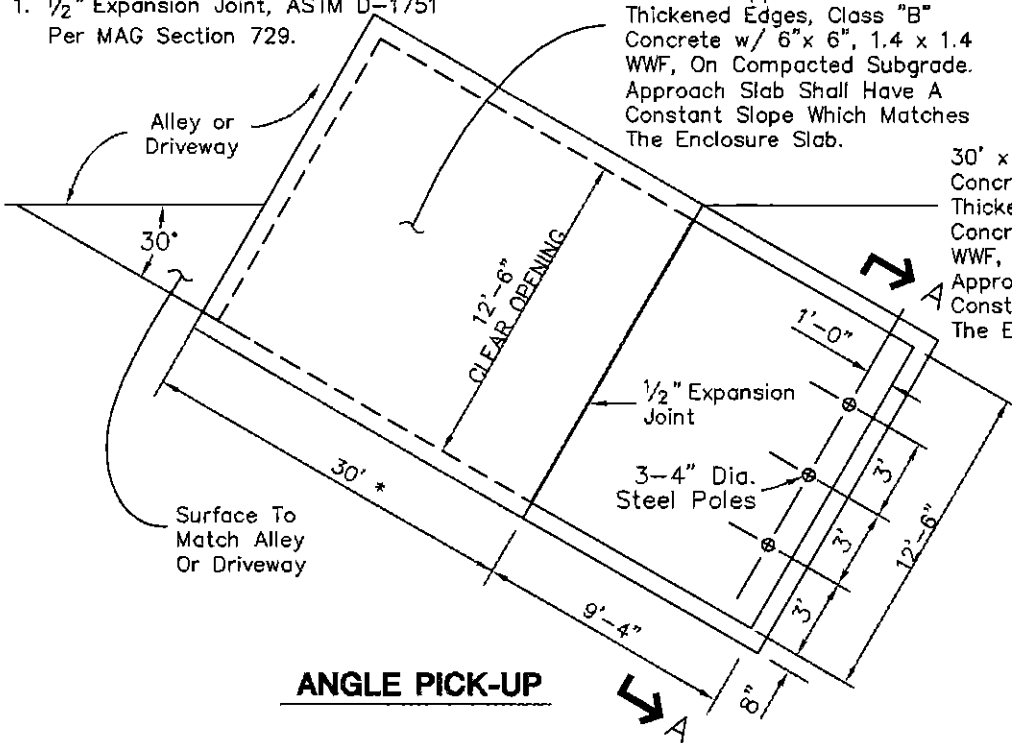

8" CMU Or Block Or Stucco To Match Building

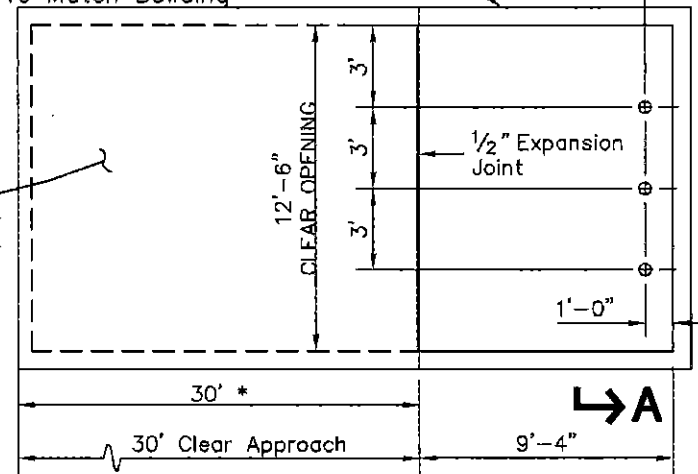

HEAD ON PICK-UP

ANGLE PICK-UP

Place 3-4" Dia. Steel Poles 60" Above Grade Cap Or Grout Full. Paint To Match Wall Color.

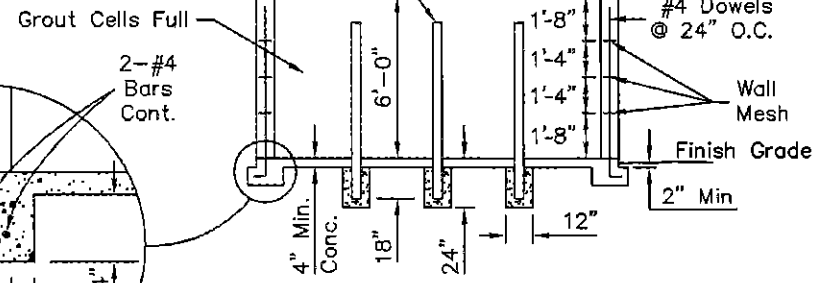

SECTION A-A

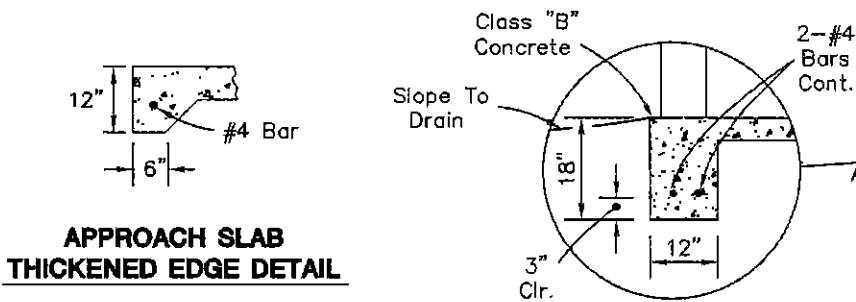

APPROACH SLAB THICKENED EDGE DETAIL

DETAIL NO. **2146-1** City of Scottsdale Standard Details

REFUSE ENCLOSURE

DETAIL NO. **2146-1**

REVISED 5/9/02

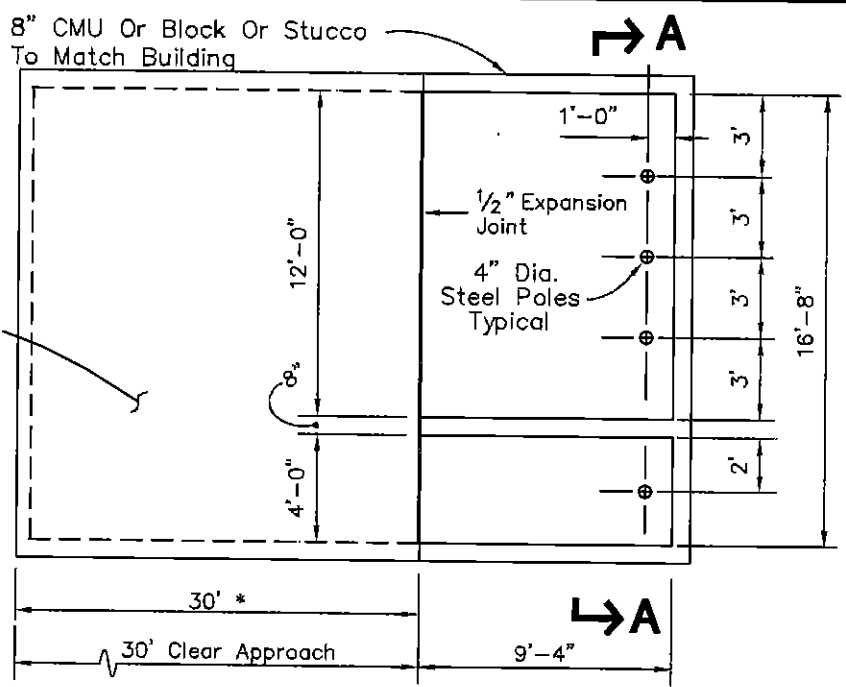
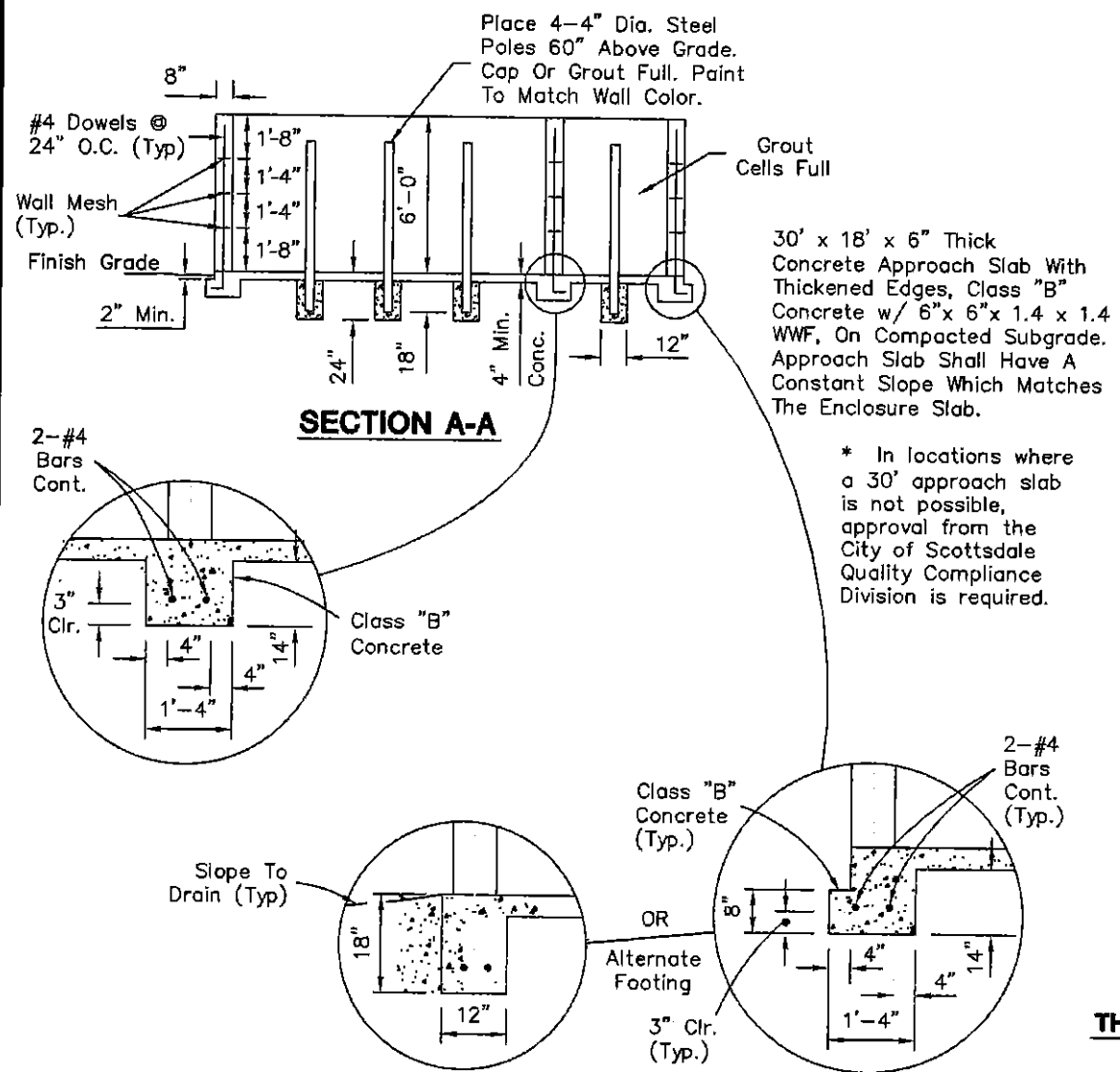

* In locations where a 30' approach slab is not possible, approval from the City of Scottsdale Quality Compliance Division is required.

PLAN

- NOTES:**
1. Enclosure For Angle Pick-up Similar To COS Detail 2146-1
 2. 1/2" Expansion Joint, ASTM D-1751 Per MAG Section 729.

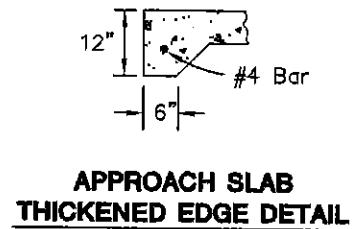

DETAIL NO. **2146-2** City of Scottsdale Standard Details

REFUSE ENCLOSURE W/ GREASE CONTAINMENT AREA

DETAIL NO. **2146-2**

Place 6-4" Dia. Steel Poles 60" Above Grade Cap Or Grout Full. Paint To Match Wall Color.

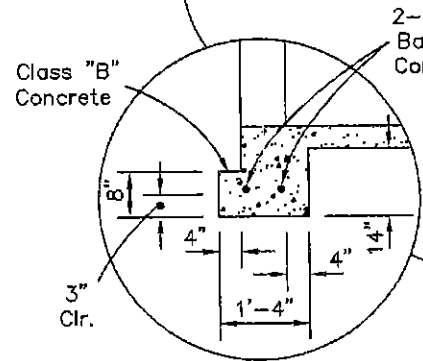
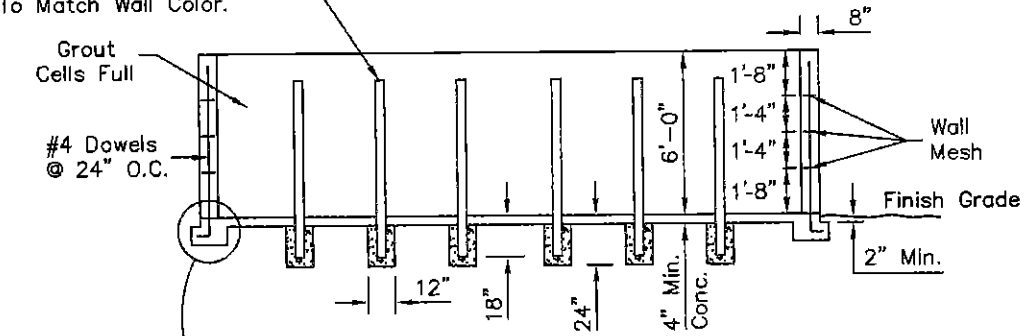

SECTION A-A

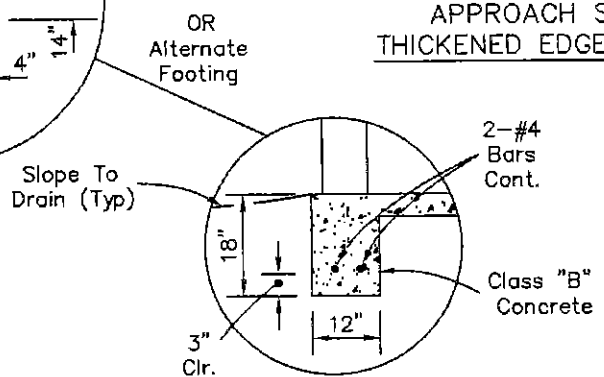
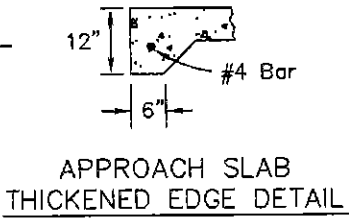

30' x 23' x 6" Thick Concrete Approach Slab With Thickened Edges, Class "B" Conc. w/ 6"x 6", 1.4 x 1.4 WWF, On Compacted Subgrade. Approach Slab Shall Have A Constant Slope Which Matches The Enclosure Slab.

* In locations where a 30' approach slab is not possible, approval from the City of Scottsdale Quality Compliance Division is required.

8" CMU Or Block Or Stucco To Match Building

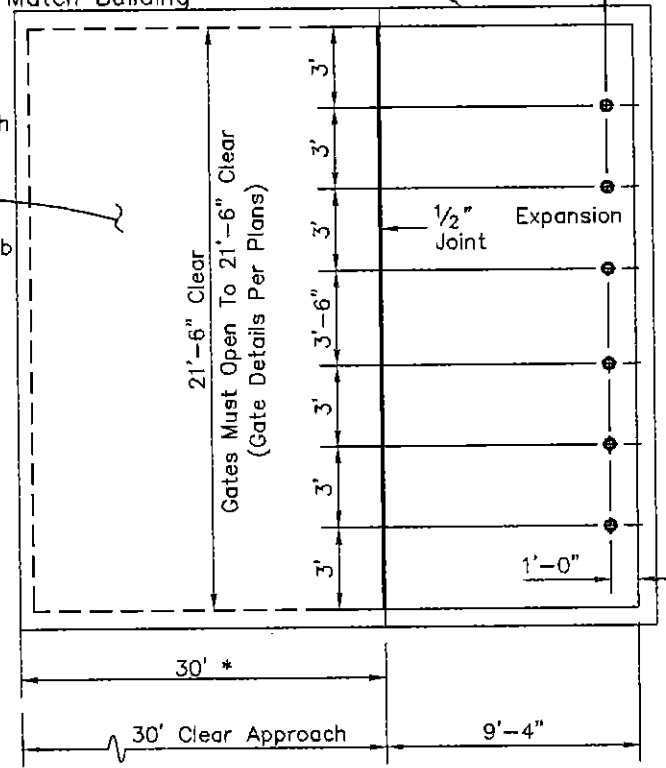

PLAN

- NOTE:
1. Double Enclosure For Angle Pick-Up Similar To COS Det. 2146-1
 2. 1/2" Expansion Joint, ASTM D-1751 Per MAG Section 729.

REVISED 3/9/02

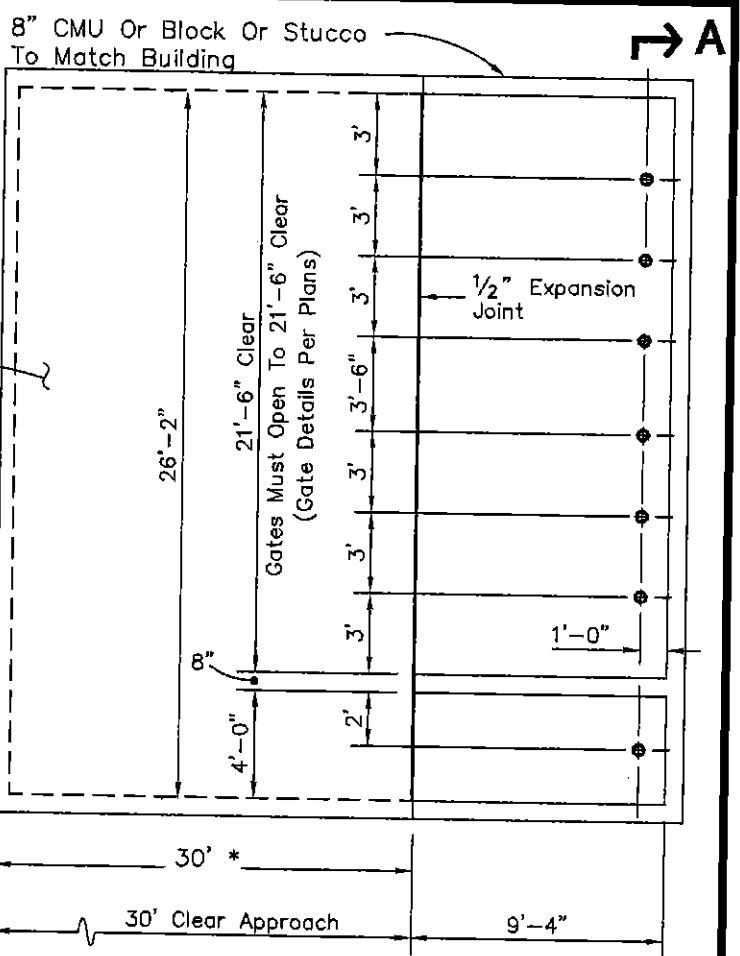
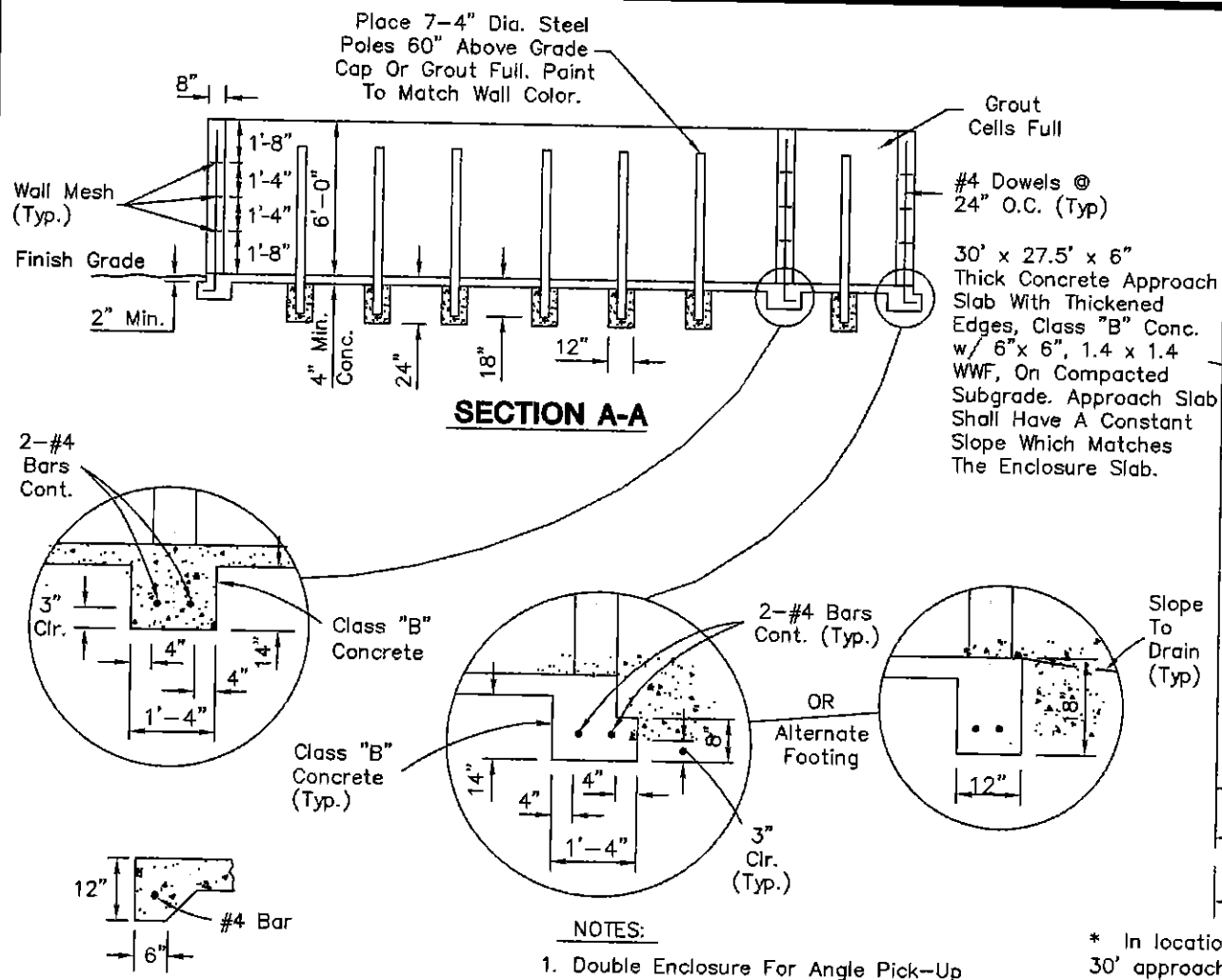

APPROACH SLAB THICKENED EDGE DETAIL

NOTES:

1. Double Enclosure For Angle Pick-Up Similar To COS Det. 2146-1
2. 1/2" Expansion Joint, ASTM D-1751 Per MAG Section 729.

* In locations where a 30' approach slab is not possible, approval from the City of Scottsdale Quality Compliance Division is required.

PLAN

DETAIL NO. **2147-2** City of Scottsdale Standard Details

DOUBLE REFUSE ENCLOSURE W/ GREASE CONTAINMENT AREA

DETAIL NO. **2147-2**

REVISED 1/3/00

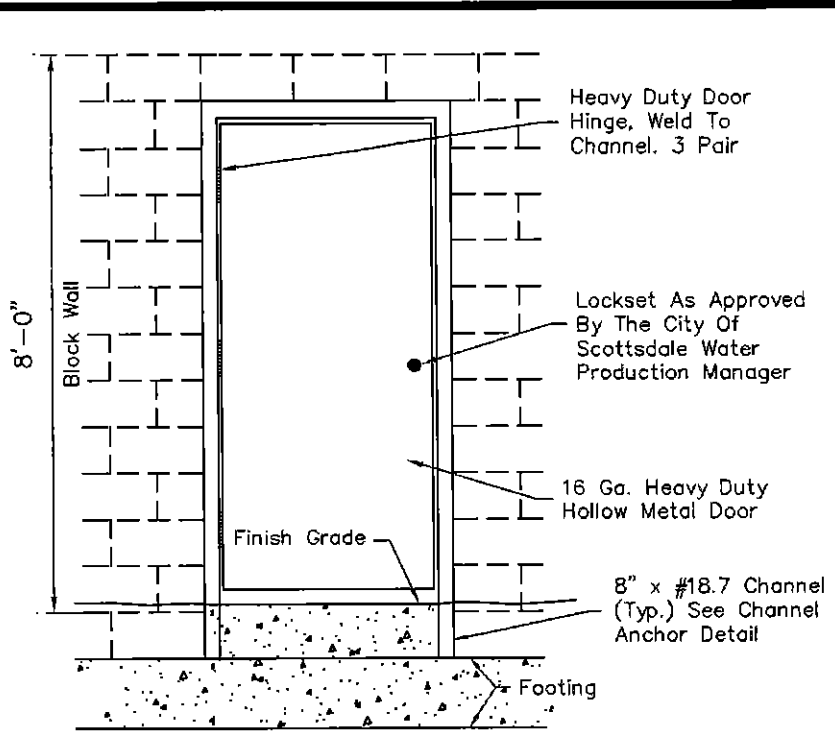

HINGED DOOR

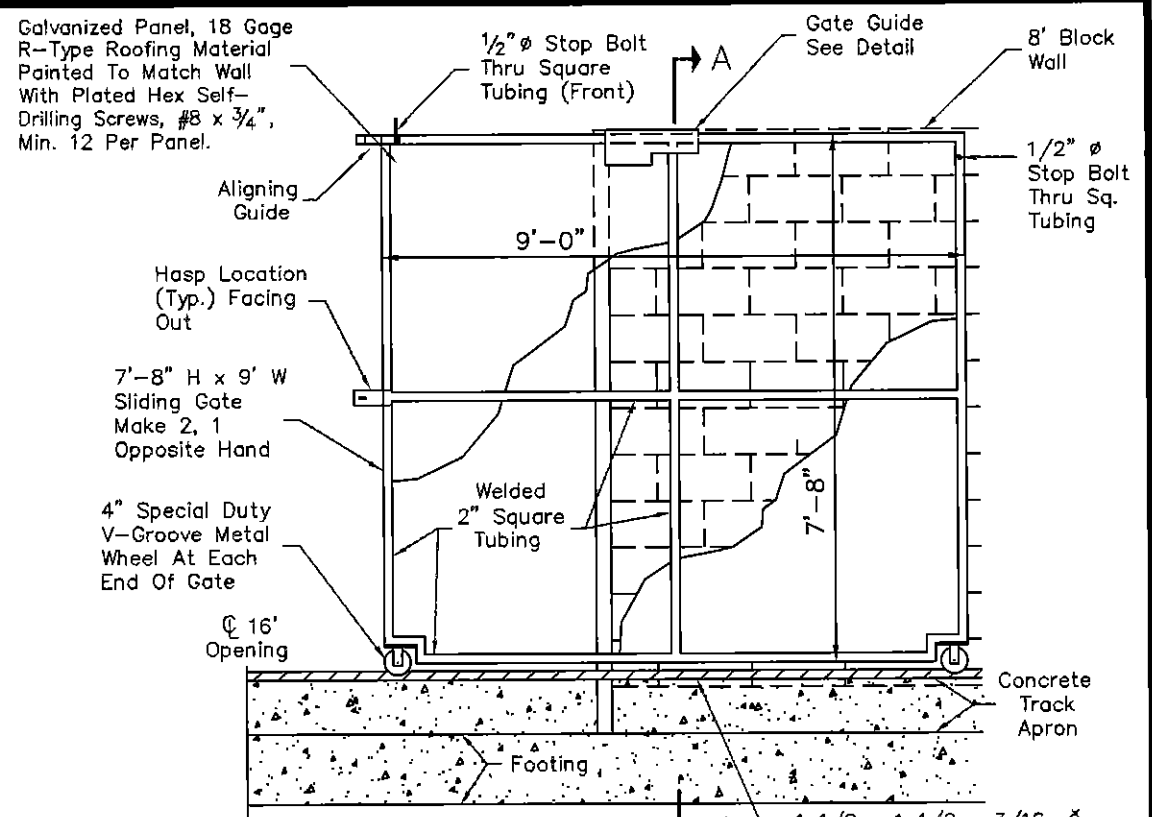

ELEVATION

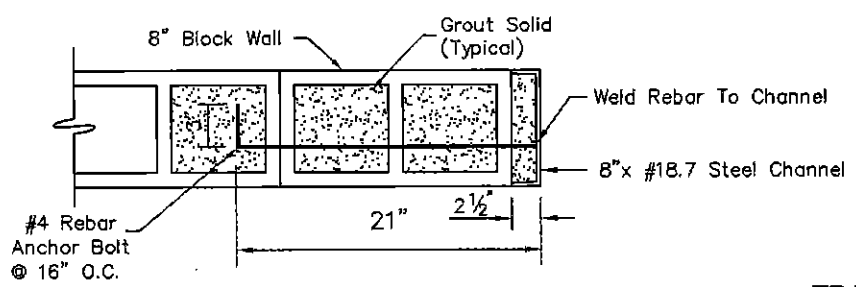

CHANNEL ANCHOR DETAIL

TRACK DETAIL

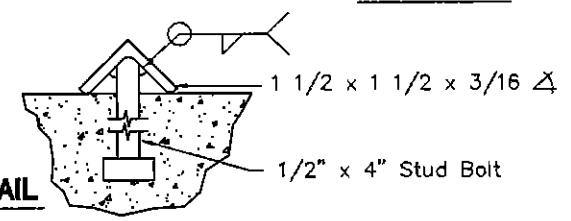

DETAIL NO. **2165-1** City of Scottsdale Standard Details

16' SLIDING GATE & HINGED DOOR

DETAIL NO. **2165-1**

REVISED 5/10/88

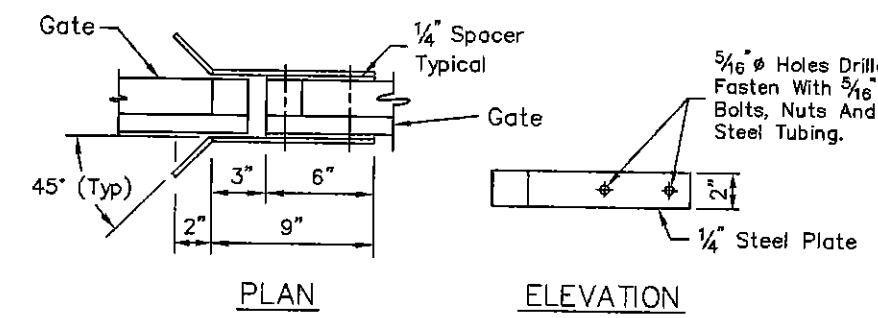
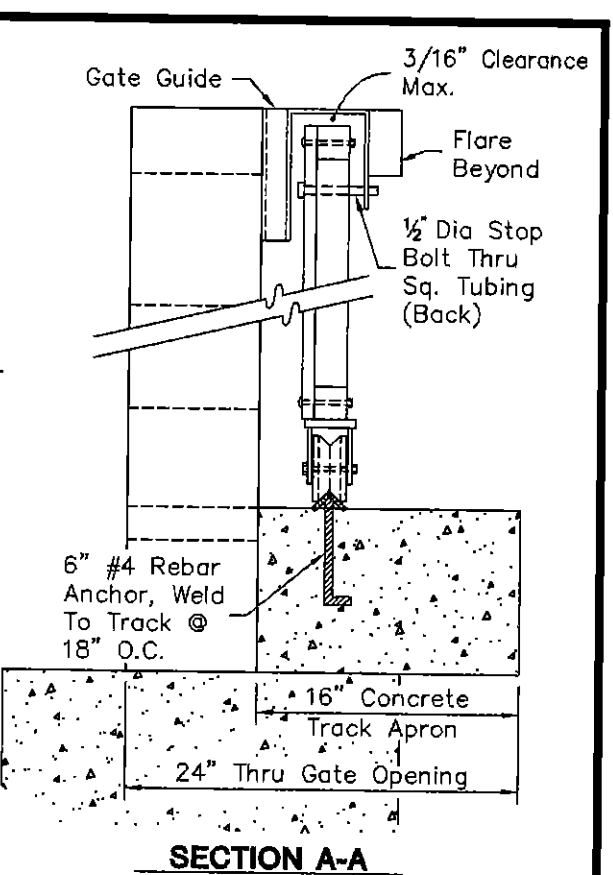
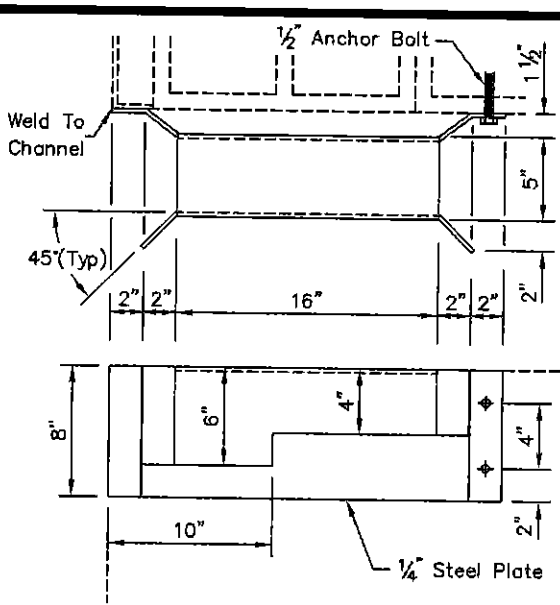
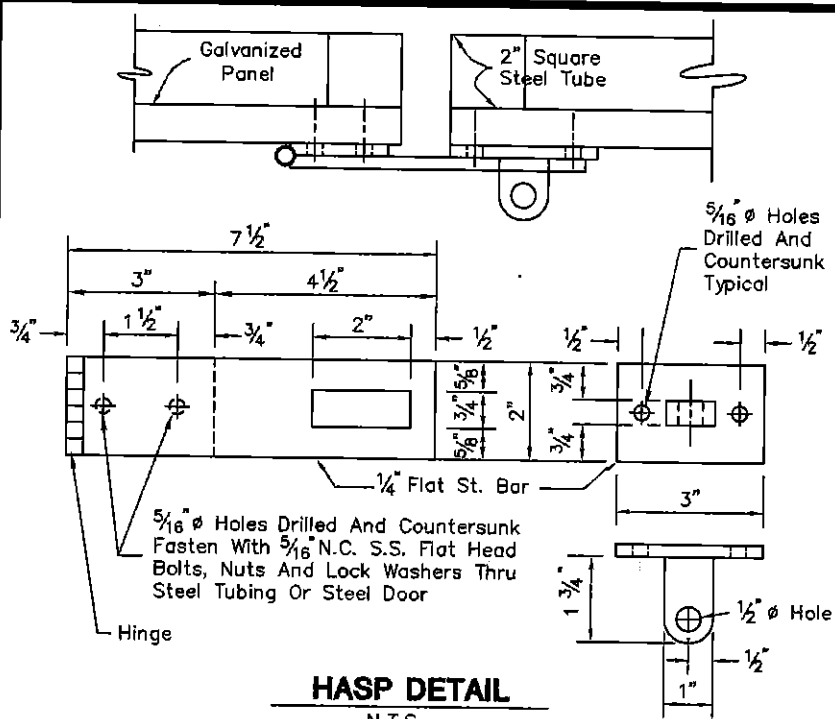

- NOTES:**
1. Contractor shall prime and paint all metal surfaces. Before application, the color and manufacturer of the paint shall be approved by the City.
 2. Prior to painting, all surfaces shall be cleaned free of concrete, mortar, rust, dirt and any other objectionable materials.
 3. Apply one (1) primer coat and two (2) exterior alkyd gloss enamel coats to metal.

DETAIL NO. 2165-2	City of Scottsdale Standard Details	APPROVED BY: _____	16' SLIDING GATE	DETAIL NO. 2165-2
-----------------------------	---	-----------------------	-------------------------	-----------------------------

REVISED 3/7/28/02

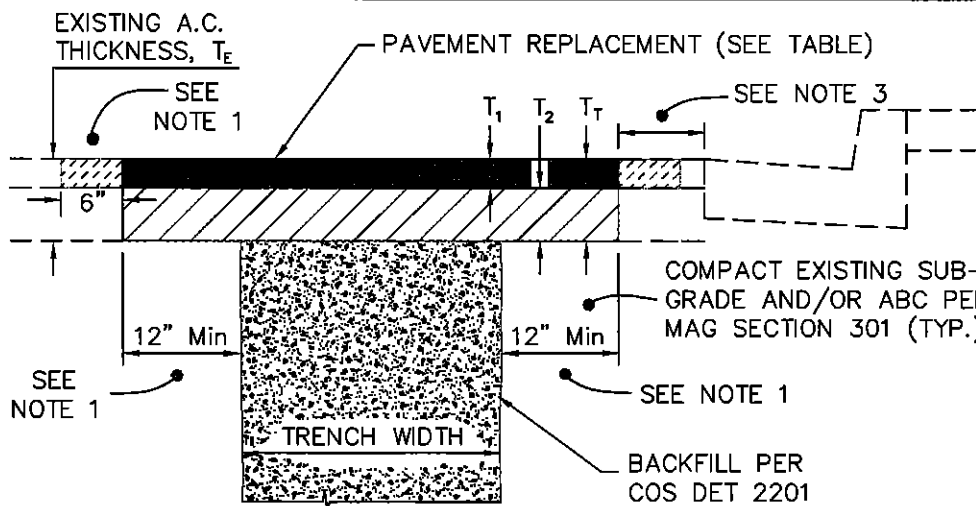

EXISTING PAVEMENT THICKNESS, T_E	AC PAVEMENT REPLACEMENT TABLE		
	AC SINGLE COURSE OR SURFACE COURSE, T_1	AC BASE COURSE, T_2	TOTAL THICKNESS, T_T
$T_E \leq 3"$	3" MINIMUM	NONE	3" MINIMUM
$T_E > 3"$	2" MINIMUM	2" MINIMUM	T_E (MATCH EXIST)

PAVEMENT REPLACEMENT NOTES

1. "T"-TOP REQUIRED FOR ALL TRENCHES. A.C. SURFACE COURSE REPLACEMENT TO BE MILLED DOUBLE "T" CONFIGURATION AS SPECIFIED BELOW FOR PAVEMENTS 4" AND THICKER.
 - a. FOR PAVEMENT 4 YEARS AND OLDER: INITIAL A.C. REMOVAL TO BE THE MINIMUM WIDTH REQUIRED FOR PROPER TRENCH COMPACTION. SAWCUT & REMOVE 12" OF A.C. MINIMUM ON EACH SIDE OF THE TRENCH FOR THE "T"-TOP AFTER THE BACKFILL MATERIAL IS PLACED. PAVEMENTS 4" AND THICKER, MILL AND REMOVE THE TOP 2" OF THE SURFACE COURSE A MINIMUM OF 6" ON EACH SIDE OF THE T-TOP PRIOR TO PLACEMENT OF THE FINAL SURFACE COURSE LIFT.
 - b. FOR NEW AND OVERLAYED PAVEMENT LESS THAN 4 YEARS OLD AND WHEN ALLOWED UNDER THE PROVISIONS OF SCOTTSDALE REVISED CODE SECTIONS 47-79 AND ALL PAVEMENTS WITH RUBBERIZED SURFACE COURSES: INITIAL A.C. REMOVAL TO BE THE MINIMUM WIDTH REQUIRED FOR PROPER TRENCH COMPACTION. SAWCUT & REMOVE 12" OF A.C. MINIMUM ON EACH SIDE OF THE TRENCH FOR THE "T"-TOP AFTER THE BACKFILL MATERIAL IS PLACED. PAVEMENTS 4" AND THICKER, MILL AND REMOVE THE TOP 2" OF THE SURFACE COURSE EQUALLY ON BOTH SIDES OF THE TRENCH TO A MINIMUM TOTAL WIDTH OF 10 FEET. FOR PAVEMENTS LESS THAN 4" THICK SAWCUT, REMOVE AND REPLACE THE ENTIRE PAVEMENT SURFACE TO A MINIMUM TOTAL WIDTH OF 10 FEET, AS DIRECTED BY THE ENGINEER.
 - c. FOR DEEP PAVEMENT STRUCTURES REQUIRING TWO OR MORE PAVEMENT BASE LIFTS: INITIAL A.C. REMOVAL TO BE THE MINIMUM WIDTH REQUIRED FOR PROPER TRENCH COMPACTION. SAWCUT, REMOVE AND REPLACE A.C. ON BOTH SIDES OF THE TRENCH AS NECESSARY TO ACCOMMODATE A RIDE ON TYPE VIBRATORY ROLLER COMPACTOR FOR PLACEMENT OF THE A.C. BASE COURSE LIFTS, MATCH EXISTING A.C. DEPTH. MILL AND REMOVE THE TOP 2" OF THE SURFACE COURSE EQUALLY ON BOTH SIDES OF THE TRENCH TO A MINIMUM TOTAL WIDTH OF 10 FEET.
2. ASPHALT CONCRETE SHALL BE IN ACCORDANCE WITH THE REQUIREMENTS OF MAG SECTION 321.
3. IF PAVEMENT REMNANT IS LESS THAN 36", REMOVE AND REPLACE PAVEMENT AS PER THIS DETAIL.
4. AGGREGATE BASE COURSE PER MAG SECTION 702 SHALL BE PROVIDED TO MATCH EXISTING ABC THICKNESS IN ADJACENT ROADWAY.
5. REFER TO COS SUPPLEMENTAL SPECIFICATIONS, SECTION 336.2.4 FOR PAVEMENT SMOOTHNESS REQUIREMENTS.

PAVEMENT REPLACEMENT FOR TRENCHES (T-TOP)

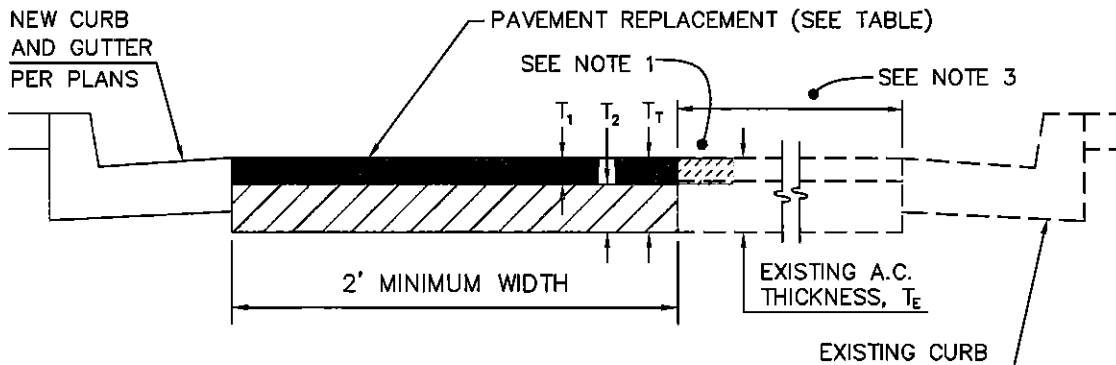

PAVEMENT REPLACEMENT

DETAIL NO.
2200

**City of Scottsdale
Standard Details**

PAVEMENT REPLACEMENT

DETAIL NO.
2200

REVISED 4/25/02

BACKFILL DETAILS

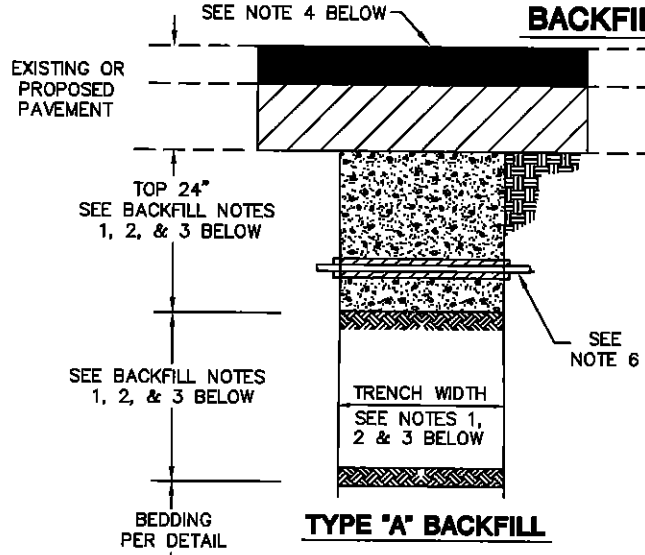

TYPE 'A' BACKFILL

**UNDER EXIST. OR PROPOSED PAVEMENT
OR EXIST. SURFACE TREATMENT**

BACKFILL NOTES

1. TRENCHES 24" IN WIDTH OR LESS - 1/2 SACK C-S-LM, MAG 728, FULL DEPTH OF BACKFILL BOTTOM OF ABC LAYER IN PAVEMENT STRUCTURE OR 6" BELOW PAVEMENT IN FULL DEPTH PAVEMENT STRUCTURES. CONSTRUCT PAVEMENT STRUCTURE TO MATCH EXISTING AND IN ACCORDANCE WITH COS DETAIL 2200.
2. TRENCHES 24" TO 6' IN WIDTH - 1/2 SACK C-S-LM AS DESCRIBED IN NOTE 1 ABOVE WITHIN THE TOP 24" OF THE TRENCH; MAG 601.4.3 FOR BALANCE OF BACKFILL.
3. TRENCHES OVER 6' IN WIDTH - MAG 601.4.3 FULL DEPTH OF BACKFILL.
4. TREAT ENTIRE DISTURBED SURFACE OF UNPAVED ALLEYS WITH LIGNIN-BASED DUST PALLATIVE, MAG 792, 1:1 DILUTION RATIO, 0.50 GAL/SY APPLICATION RATE.
5. C-S-LM SHALL NOT BE USED FOR WATER OR SEWER PIPE BEDDING. SEE BEDDING DETAIL.
6. EXPOSED COPPER OR POLYETHYLENE WATER PIPES IN SIZES 1/2" TO 2" SHALL BE WRAPPED WITH 1/2" WIDE BLACK INSULATION BEFORE PLACING C-S-LM.
7. RECYCLED ASPHALT SHALL NOT BE USED FOR BACKFILL.

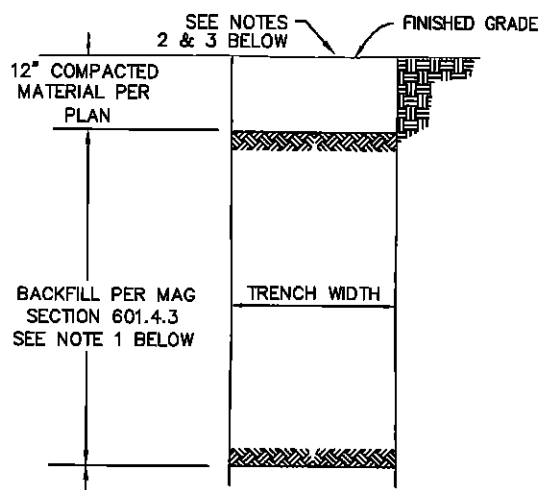

TYPE 'B' BACKFILL

**UNDER UNPAVED
ROADWAY, PARKING LOT
AND VACANT LAND**

BACKFILL NOTES

1. MAG 601.4.3 FULL DEPTH OF BACKFILL.
2. ENTIRE DISTURBED EXISTING SURFACE TO BE RESTORED WITH A LIKE MATERIAL.
3. TREAT ENTIRE DISTURBED SURFACE WITH LIGNIN-BASED DUST PALLATIVE, MAG 792, 1:1 DILUTION RATIO, 0.50 GAL/SY APPLICATION RATE.
4. RECYCLED ASPHALT SHALL NOT BE USED FOR BACKFILL.

BEDDING DETAILS

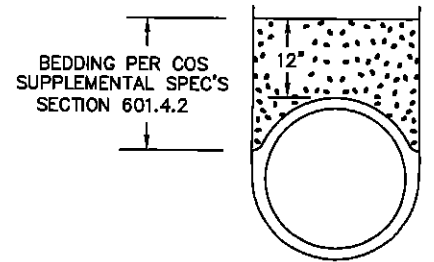

**BEDDING DETAIL
CAST-IN-PLACE PIPE**

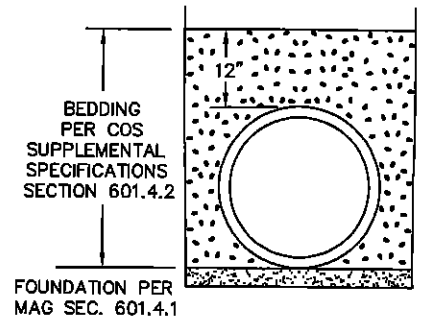

**BEDDING DETAIL
ALL OTHER PIPE**

NOTES:

1. FOR HDPE PIPE - SEE COS SUPPLEMENTAL SPECIFICATIONS SECTION 603.4.2
2. RECYCLED ASPHALT SHALL NOT BE USED FOR BEDDING OR FOUNDATION MATERIAL.

DETAIL NO.
2201

**City of Scottsdale
Standard Details**

TRENCH BEDDING & BACKFILL

DETAIL NO.
2201

REVISED: 4/25/02

NOTES:

1. The contractor shall provide adequate overlap of plate on asphalt to assure no slippage of plate and no collapsing of trench.
2. "Posted Speed" does not include temporary construction signing.

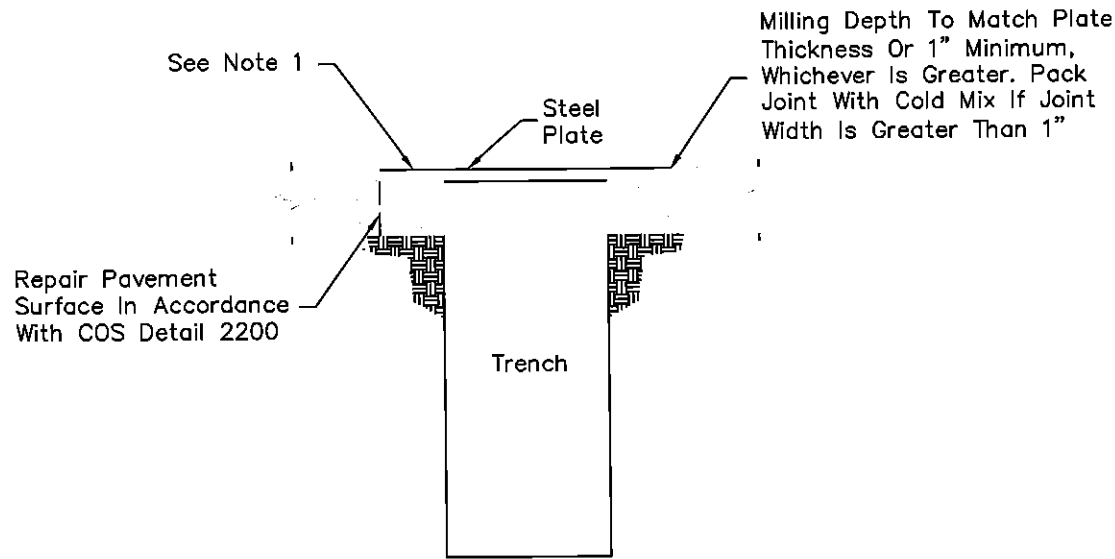

TYPE 'A' PLATING

CITY POSTED SPEEDS OF 35 MPH AND GREATER OR BUS & TRUCK ROUTE

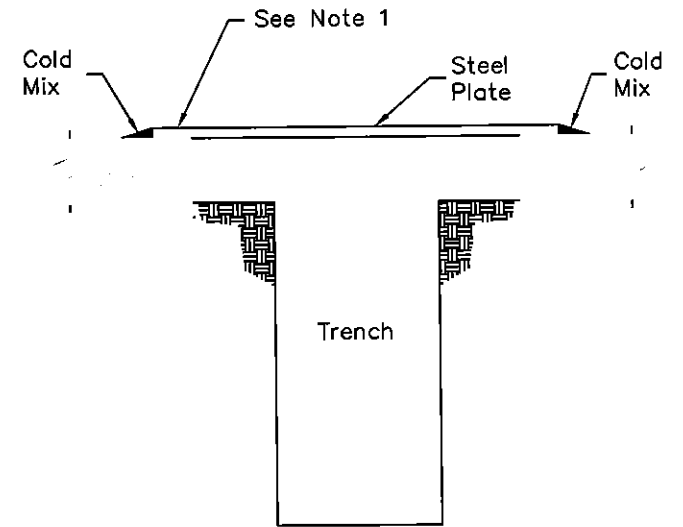

TYPE 'B' PLATING

CITY POSTED SPEEDS UNDER 35 MPH

DETAIL NO.
2202

**City of Scottsdale
Standard Details**

APPROVED BY:

TRENCH PLATING

DETAIL NO.
2202

REVISED: 3/28/02

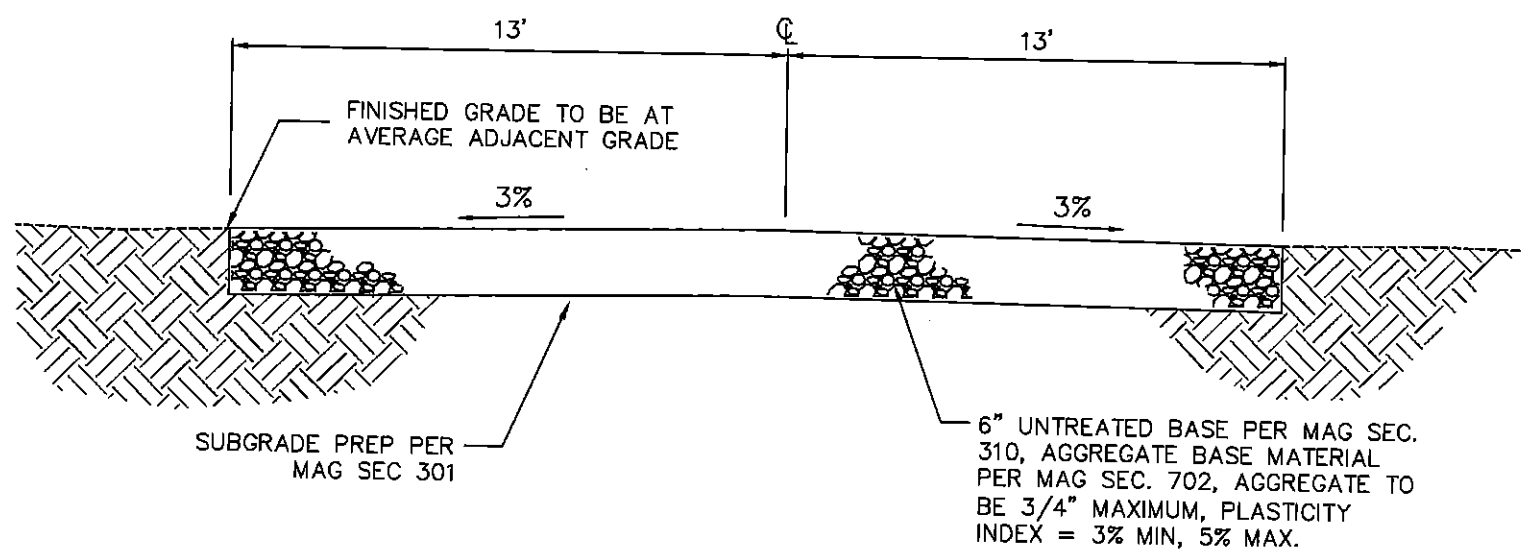

UNPAVED ROAD DETAIL

DETAIL NO. 2207	City of Scottsdale Standard Details
---------------------------	---

RESIDENTIAL UNPAVED ROAD

DETAIL NO. 2207

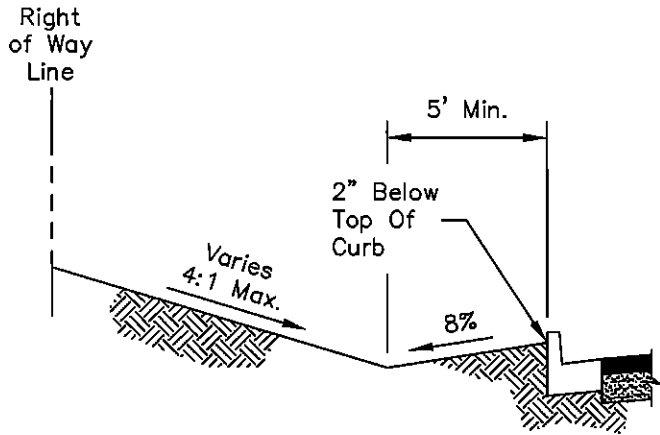

NO SIDEWALK

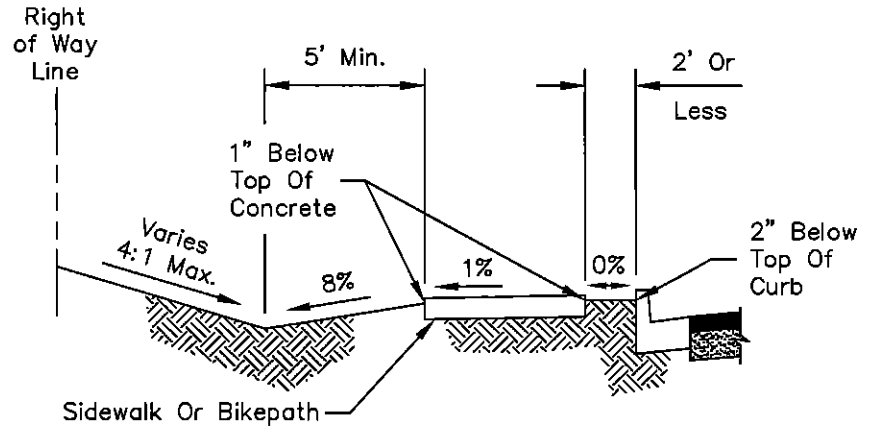

SIDEWALK LESS THAN 2' BEHIND CURB

NOTE:

Runoff Shall Not Be Directed To Cross Over The Top Of A Sidewalk.

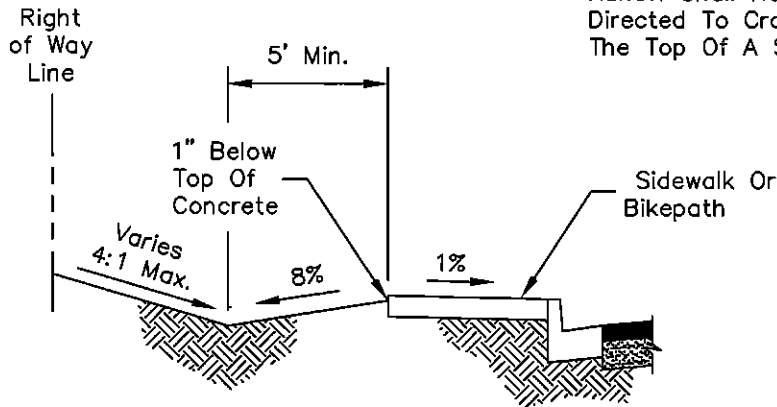

SIDEWALK AT BACK OF CURB

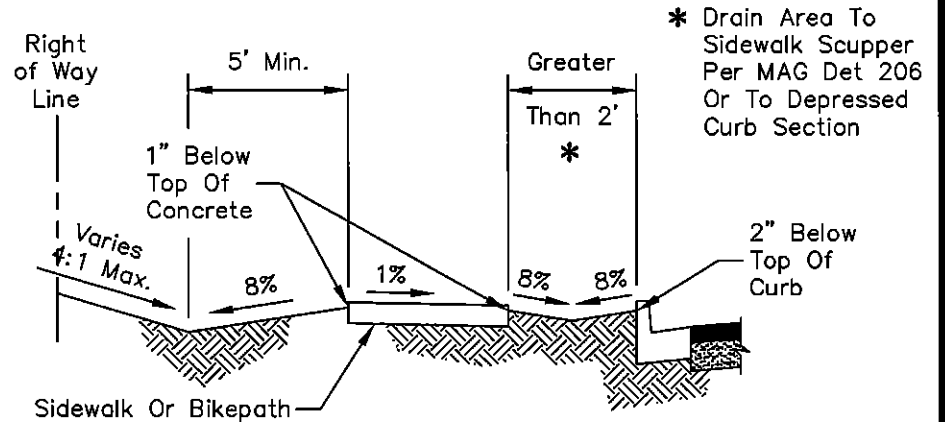

SIDEWALK MORE THAN 2' BEHIND CURB

DETAIL NO.
2210

**City of Scottsdale
Standard Details**

APPROVED BY:

GRADING BEHIND THE CURB

DETAIL NO.
2210

REVISED 4/7/00

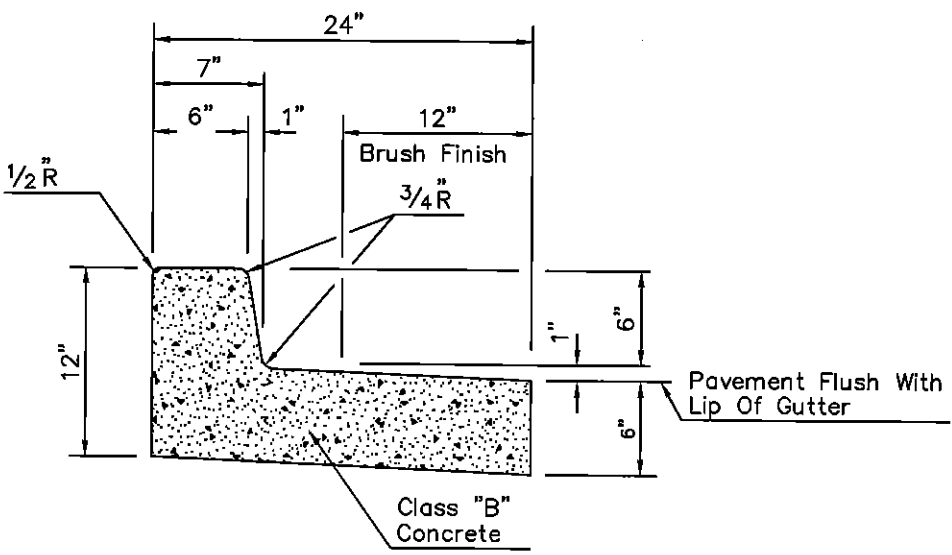

**VERTICAL CURB & GUTTER
WITH DEPRESSED LIP**
TYPE 'A'

NOTES

1. All exposed surfaces to be trowel finished except as shown. See M.A.G. Section 340.
2. Contraction joint spacing 10' maximum.
3. Construct curb and install 1/2" mastic expansion joints, A.S.T.M. D-1751, per M.A.G. Sec. 340 & 729 and COS Sec. 340.
4. Colored concrete shall be colored integrally.

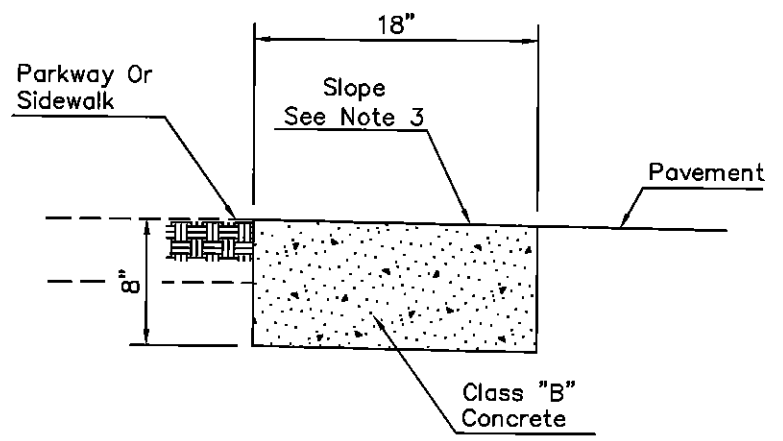

RIBBON CURB
TYPE 'B'

NOTES

1. Construct curb and install 1/2" mastic expansion joints, A.S.T.M. D-1751, per M.A.G. Sec. 340 & 729 and COS Sec 340.
2. Broom finish all surfaces.
3. Ribbon curb may slope towards pavement or parkway. Match cross slope of road unless indicated otherwise on plans.
4. Contraction joint spacing 10' maximum.
5. Colored concrete shall be colored integrally.

DETAIL NO. **2220** **City of Scottsdale**
Standard Details

CURB AND GUTTER - TYPES A & B

DETAIL NO. **2220**

REVISED 3/28/02

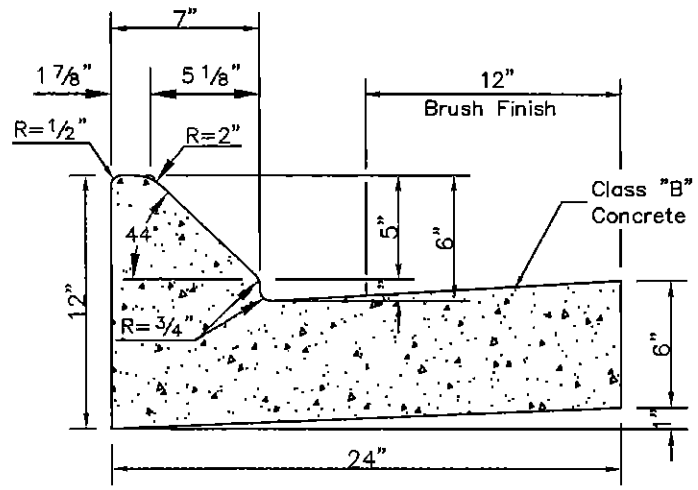

MOUNTABLE/MEDIAN CURB & GUTTER
TYPE "M"

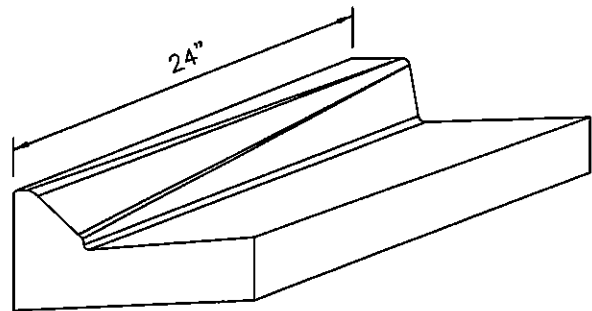

MOUNTABLE CURB TO VERTICAL CURB TRANSITION

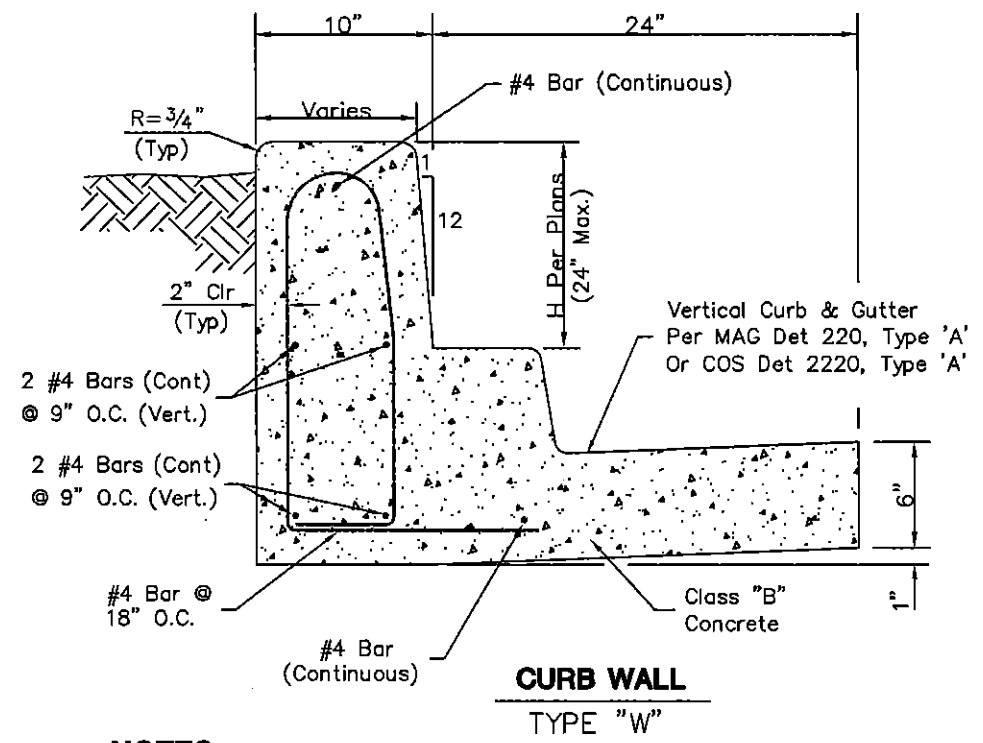

NOTES

1. All exposed surfaces to be trowel finished except as shown. See M.A.G. Section 340.
2. Contraction joint spacing 10' maximum.
3. Construct curb and install 1/2" mastic expansion joints, A.S.T.M. D-1751, per M.A.G. Sec. 340 & 729 and C.O.S. Sec. 340.
4. Gutter lip may be depressed where indicated on plans and constructed as shown on COS Detail 2220, Type "A".
5. Colored concrete, if called for on the plans, shall be colored integrally.
6. Steel reinforcement Per M.A.G. Section 727.

DETAIL NO. 2221	City of Scottsdale Standard Details	APPROVED BY: _____
---------------------------	---	-----------------------

CURB & GUTTER - TYPES M & W

DETAIL NO. 2221

MEDIAN NOSE CURVE DATA

CURVE	RADIUS*	LENGTH	TANGENT	CHORD	DELTA
C3	59.5'	19.06'	9.61'	18.97'	18°20'59"
C4	0.50'	1.41'	3.10'	0.99'	161°39'01"

 Paint Top And Front Of Curb With ReflectORIZED Yellow Traffic Paint And Add Type "D" Yellow Two Way Reflective Raised Pavement Markers to Median Nose, Spaced at 5-feet.

Note: Extend Median Treatment to a Width of 6 feet or as shown on the plans.

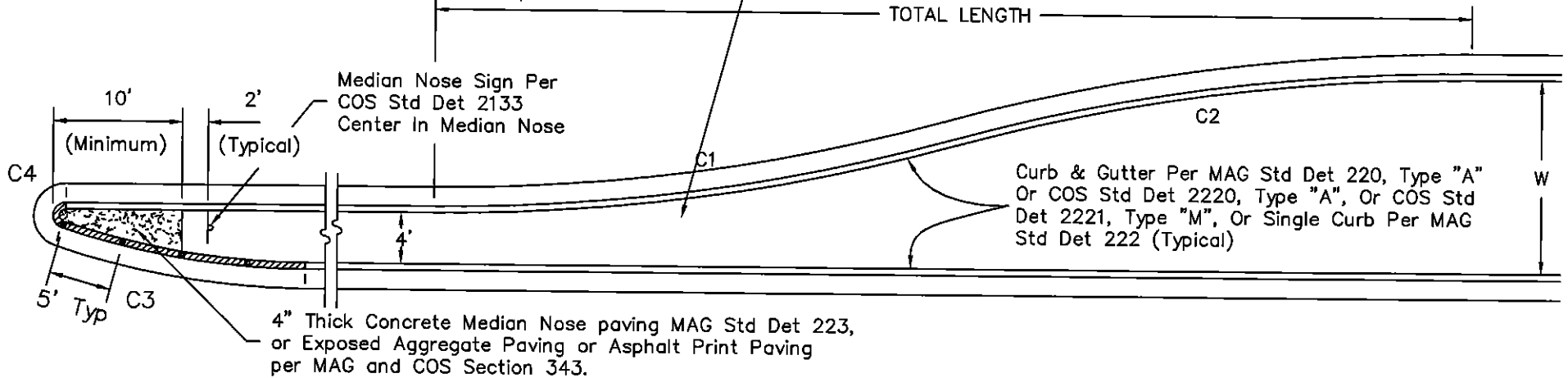

STREET CLASSIFICATION	TYPE A COLLECTOR STREET		TYPE B MINOR ARTERIAL		TYPE C MAJOR ARTERIAL		TYPE D DUAL LEFT TURN LANES		TYPE E MINOR ARTERIAL		TYPE F MAJOR ARTERIAL	
TOTAL LENGTH	80.49'		98.89'		114.36'		164.53'		103.23'		153.62'	
MEDIAN WIDTH, W	15'		15'		15'		27'		16'		24'	
CURVE NUMBER	C1	C2	C1	C2	C1	C2	C1	C2	C1	C2	C1	C2
RADIUS *	150.00'	150.00'	150.00'	300.00'	300.00'	300.00'	300.00'	300.00'	150.00'	300.00'	300.00'	300.00'
DELTA	15°33'49"	15°33'49"	12°41'40"	12°41'40"	10°59'17"	10°59'17"	15°54'56"	15°54'56"	13°15'41"	13°15'41"	14°50'06"	14°50'06"
LENGTH	40.75'	40.75'	33.23'	66.47'	57.53'	57.53'	83.33'	83.33'	34.72'	69.44'	77.68'	77.68'
TANGENT	20.50'	20.50'	16.69'	33.37'	28.86'	28.86'	41.94'	41.94'	17.44'	34.87'	39.06'	39.06'
CHORD	40.62'	40.62'	33.17'	66.33'	57.45'	57.45'	83.07'	83.07'	34.64'	69.28'	83.07'	83.07'

* ALL RADII AND DIMENSIONS TO BACK OF CURB

NOTE: Curve Data Shown Is For Streets On Linear Alignments Only.

DETAIL NO.
2225 City of Scottsdale
Standard Details

MEDIAN NOSE & REVERSE CURVE DETAILS

DETAIL NO.
2225

REVISED 3/28/02

REVISED 3/28/02

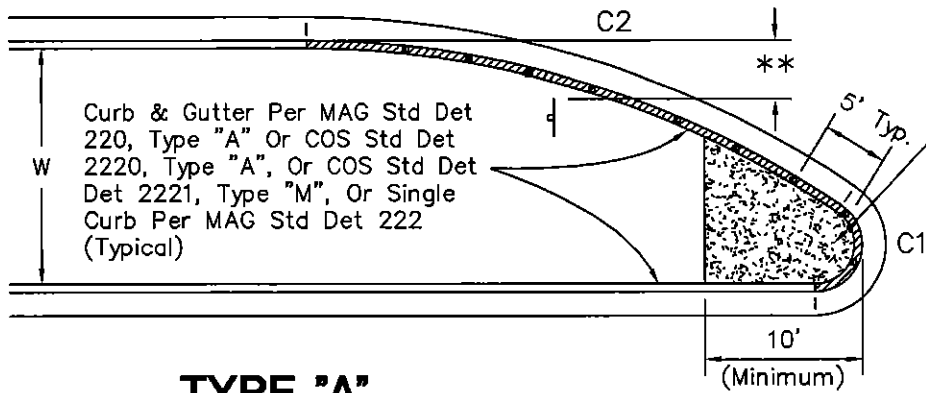

TYPE "A"

Curb & Gutter Per MAG Std Det 220, Type "A" Or COS Std Det 2220, Type "A", Or COS Std Det 2221, Type "M", Or Single Curb Per MAG Std Det 222 (Typical)

4" Thick Concrete Median Nose Paving
MAG Std Det 223, or Exposed Aggregate Paving or Asphalt Print Paving per MAG and COS Section 343 (Typical)

* ALL RADII AND DIMENSIONS TO BACK OF CURB

** OFFSET TO BE NO MORE THAN 3' FROM FACE OF CURB AT TANGENT TO EDGE OF SIGN

CURVE DATA - W=15'

CURVE	RADIUS*	LENGTH	TANGENT	CHORD	DELTA
C1	2.50'	6.35'	8.06'	4.78'	145°32'39"
C2	59.50'	35.78'	18.45'	35.24'	34°27'21"
C3	2.50'	5.74'	5.57'	4.56'	131°38'42"
C4	59.50'	25.11'	12.74'	24.92'	24°10'39"

Paint Top And Front Of Curb With ReflectORIZED Yellow Traffic Paint And Add Type "D" Yellow Reflective Raised Pavement Markers to Median Nose, Spaced at 5-feet.

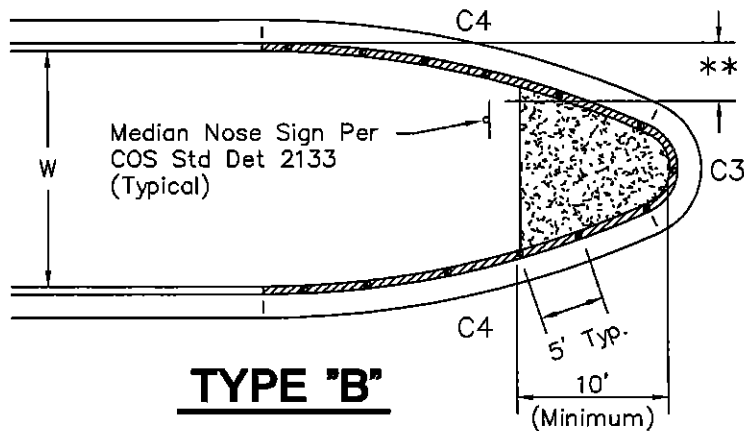

TYPE "B"

Median Nose Sign Per COS Std Det 2133 (Typical)

CURVE DATA - W=16'

CURVE	RADIUS*	LENGTH	TANGENT	CHORD	DELTA
C1	2.50'	6.27'	7.65'	4.75'	143°48'20"
C2	59.50'	37.59'	19.44'	36.97'	36°11'40"
C3	2.50'	5.64'	5.27'	4.52'	129°14'46"
C4	59.50'	26.35'	13.40'	26.14'	25°22'37"

CURVE DATA - W=24'

CURVE	RADIUS*	LENGTH	TANGENT	CHORD	DELTA
C1	2.50'	5.75'	5.59'	4.56'	131°48'37"
C2	59.50'	50.04'	26.61'	48.58'	48°11'23"
C3	2.50'	4.93'	3.77'	4.17'	112°53'08"
C4	59.50'	34.85'	17.94'	34.35'	33°33'26"

DETAIL NO.
2226

**City of Scottsdale
Standard Details**

MEDIAN NOSE DETAILS

DETAIL NO.
2226

REVISED 2/22/99

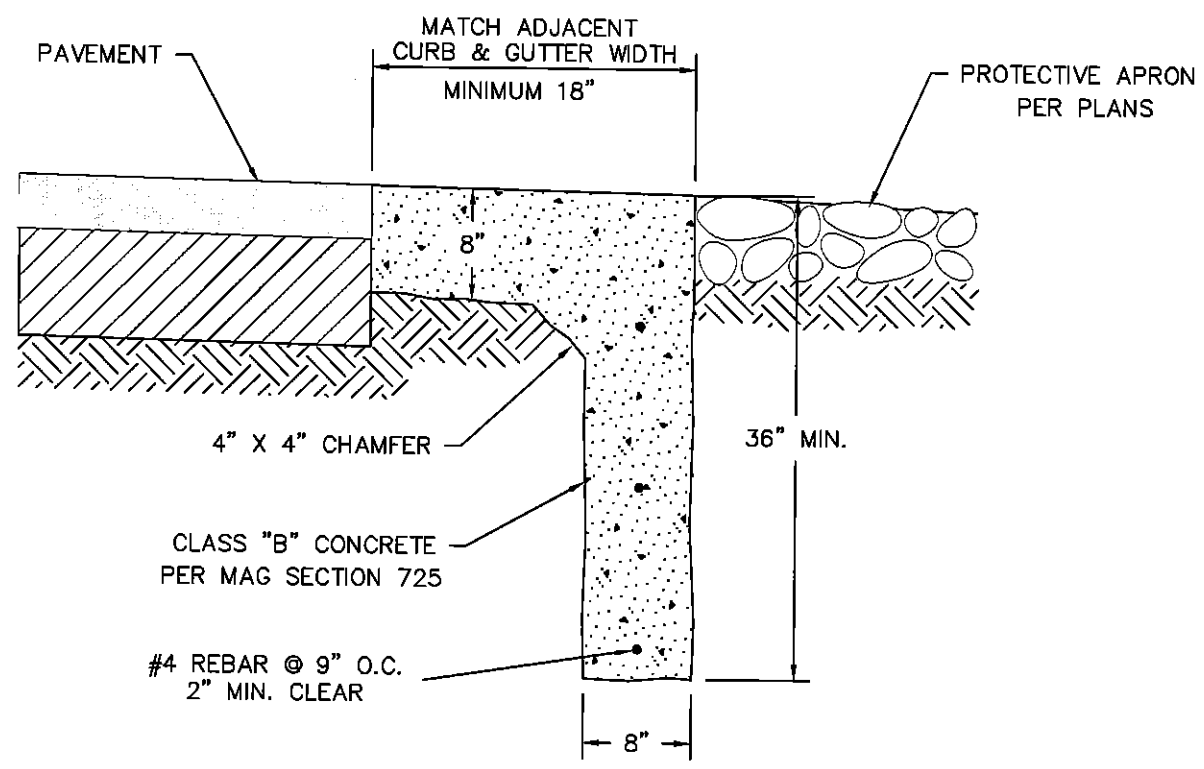

NOTE: Form The Top 8" Of Cut-Off Wall

DETAIL NO.
2228

City of Scottsdale
Standard Details

APPROVED BY:

CUT-OFF WALL

DETAIL NO.
2228

D = Pole Diameter
Range: 12"–17"

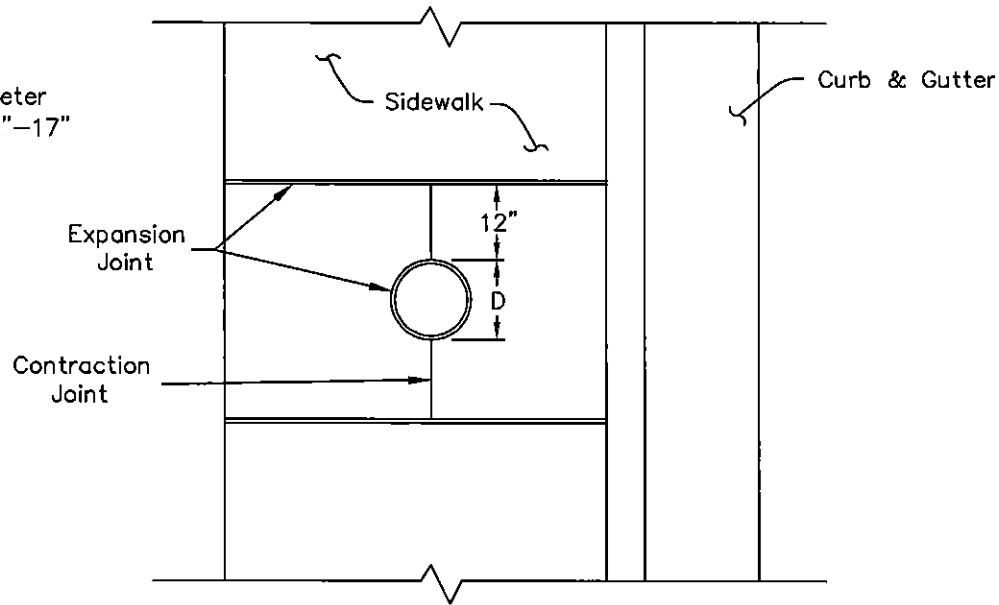

NOTES

Install expansion joint around wood pole.

Install expansion joint at sidewalk 1/4" lower than sidewalk

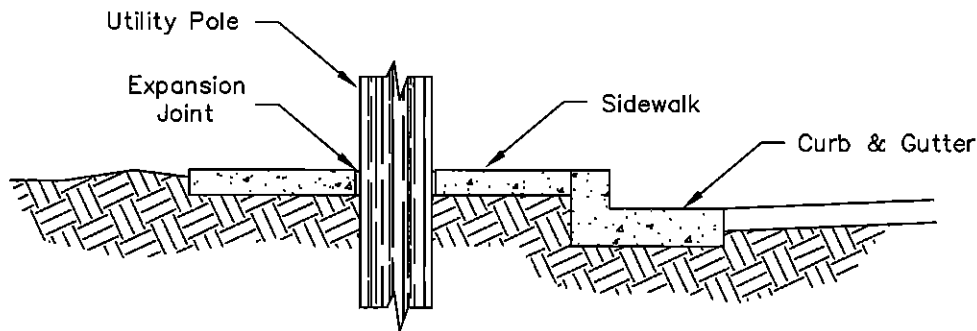

DETAIL NO.
2230

City of Scottsdale
Standard Details

APPROVED BY:

SIDEWALK CUTOUT FOR UTILITY POLES

DETAIL NO.
2230

REVISED 3/28/02

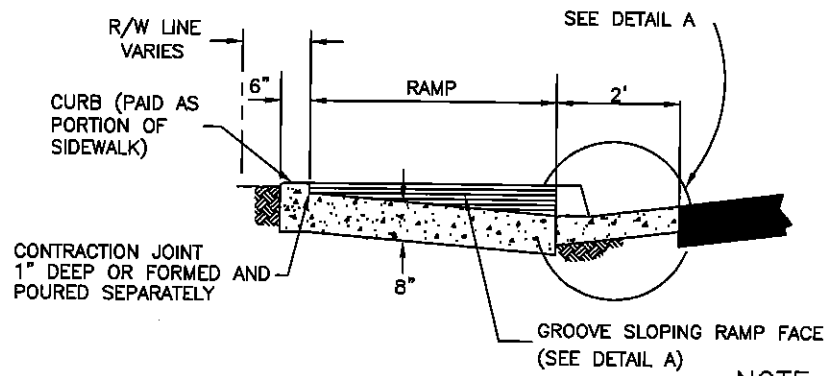
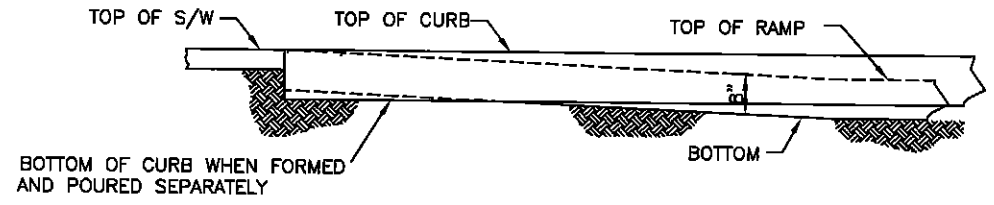
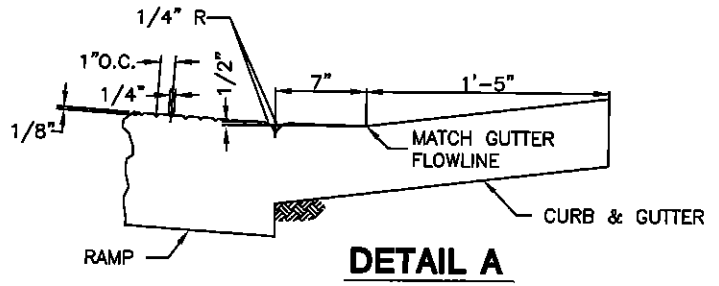
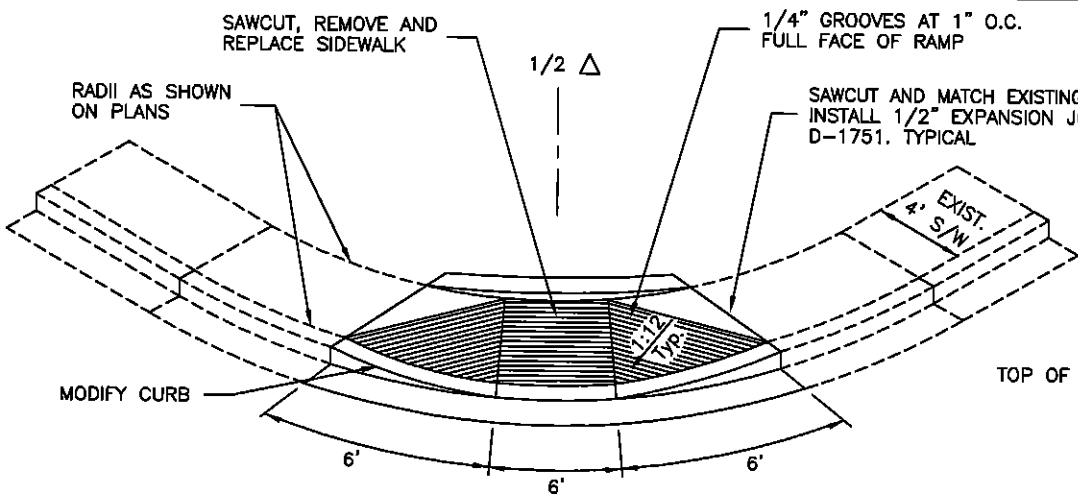

SECTION A-A

SECTION B-B

* IF EXISTING CURB IS OTHER THAN 6", ADJUST OTHER HEIGHTS ACCORDINGLY

** T.R. IS ALWAYS 3"

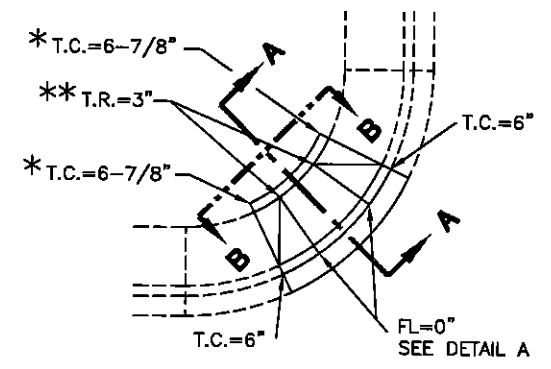

CONTROL ELEVATIONS

NOTE:

1. CONTROL ELEVATIONS SHOWN ARE IN RELATION TO THE GUTTER AND ARE LOCATED RADIALLY. GUTTER ELEVATION=0
2. CURB AND GUTTER TO BE POURED MONOLITHICALLY WITH SIDEWALK AND RAMP.

DETAIL NO. **2232** City of Scottsdale Standard Details

SIDEWALK RAMP RETROFIT

DETAIL NO. **2232**

NOTES:

1. 1/2" Expansion Joint, ASTM D-1751
Per MAG Sec. 729, and Elastomeric Sealant
Per COS Sec. 342.3.4.
2. Contraction Joints Per COS Supplemental
Specifications Sec. 342.
3. Materials And Construction Per COS
Supplemental Specifications Sec. 342.

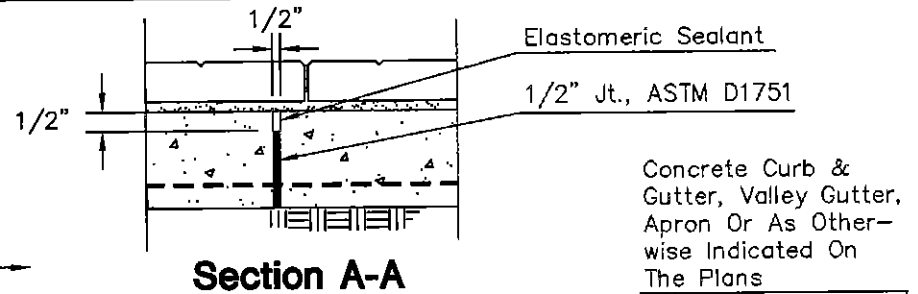

Section A-A
Expansion or Construction Joint

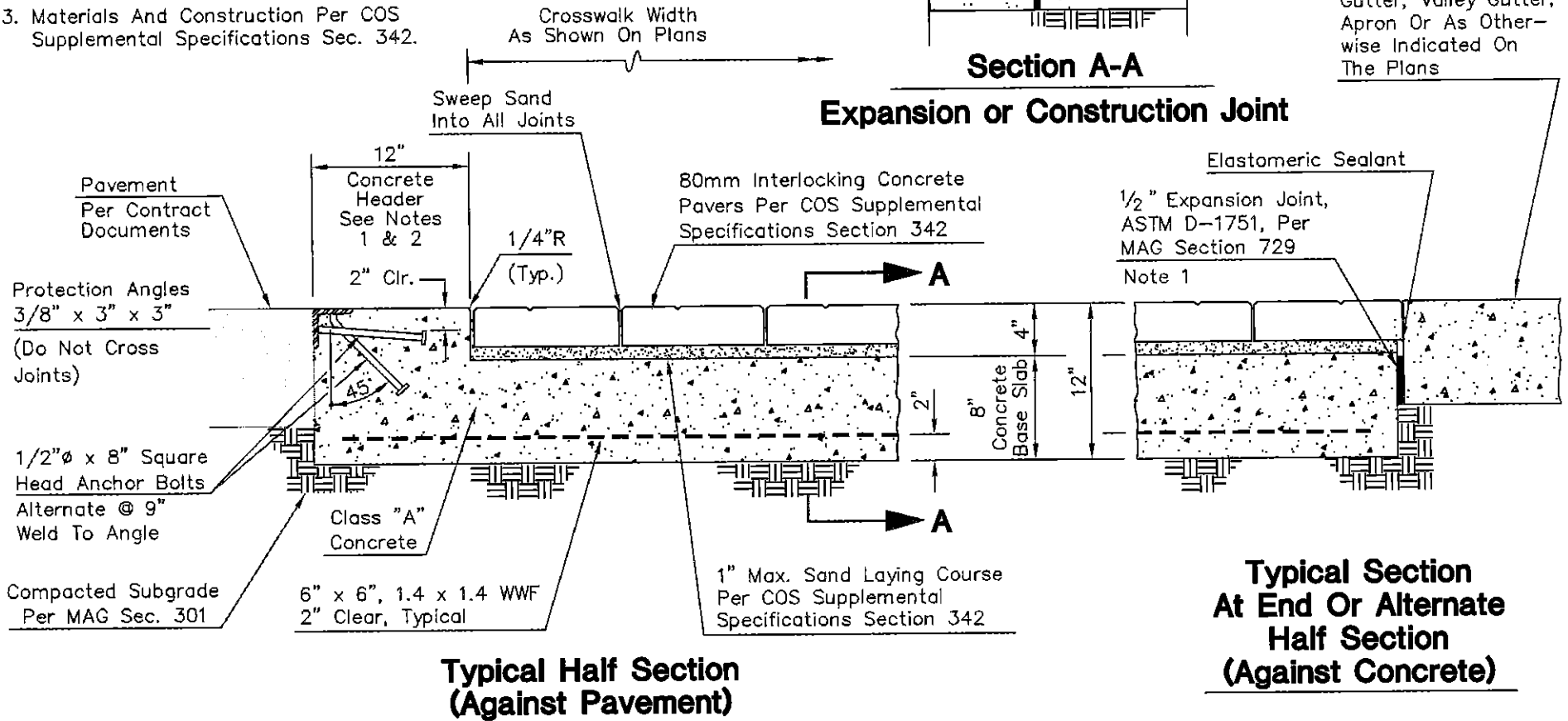

Typical Half Section
(Against Pavement)

Typical Section
At End Or Alternate
Half Section
(Against Concrete)

DETAIL NO.
2238

City of Scottsdale
Standard Details

CONCRETE PAVER CROSSWALK

DETAIL NO.
2238

REVISED 2/27/01

REVISED 2/26/01

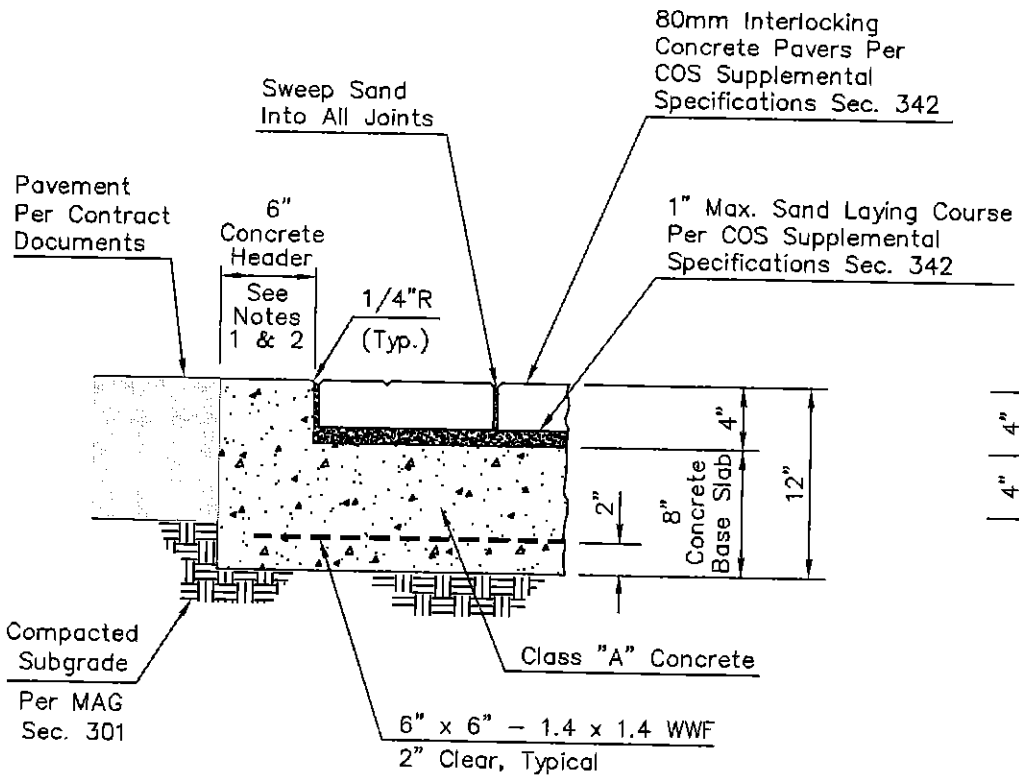

**Type "B"
Flush Median**

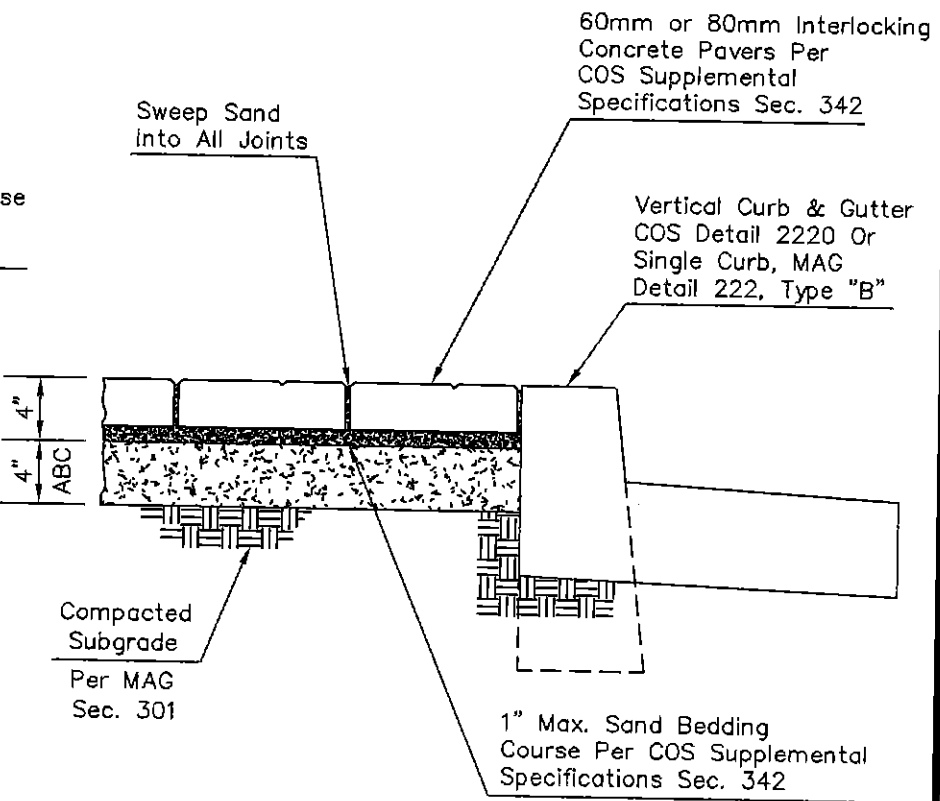

**Type "A"
Raised Median**

80mm Interlocking Concrete Pavers Per COS Supplemental Specifications Sec. 342

60mm or 80mm Interlocking Concrete Pavers Per COS Supplemental Specifications Sec. 342

1" Max. Sand Laying Course Per COS Supplemental Specifications Sec. 342

Sweep Sand into All Joints

Vertical Curb & Gutter COS Detail 2220 Or Single Curb, MAG Detail 222, Type "B"

NOTES:

1. 1/2" Expansion Joint, ASTM D-1751 Per MAG Sec. 729, Every 50'.
2. Contraction Joints Per COS Supplemental Specifications Sec. 342, Every 10'.
3. Materials And Construction Per COS Supplemental Specifications Sec. 342.

DETAIL NO.
2239

**City of Scottsdale
Standard Details**

MEDIAN CONCRETE PAVERS

DETAIL NO.
2239

REVISED 2/27/01

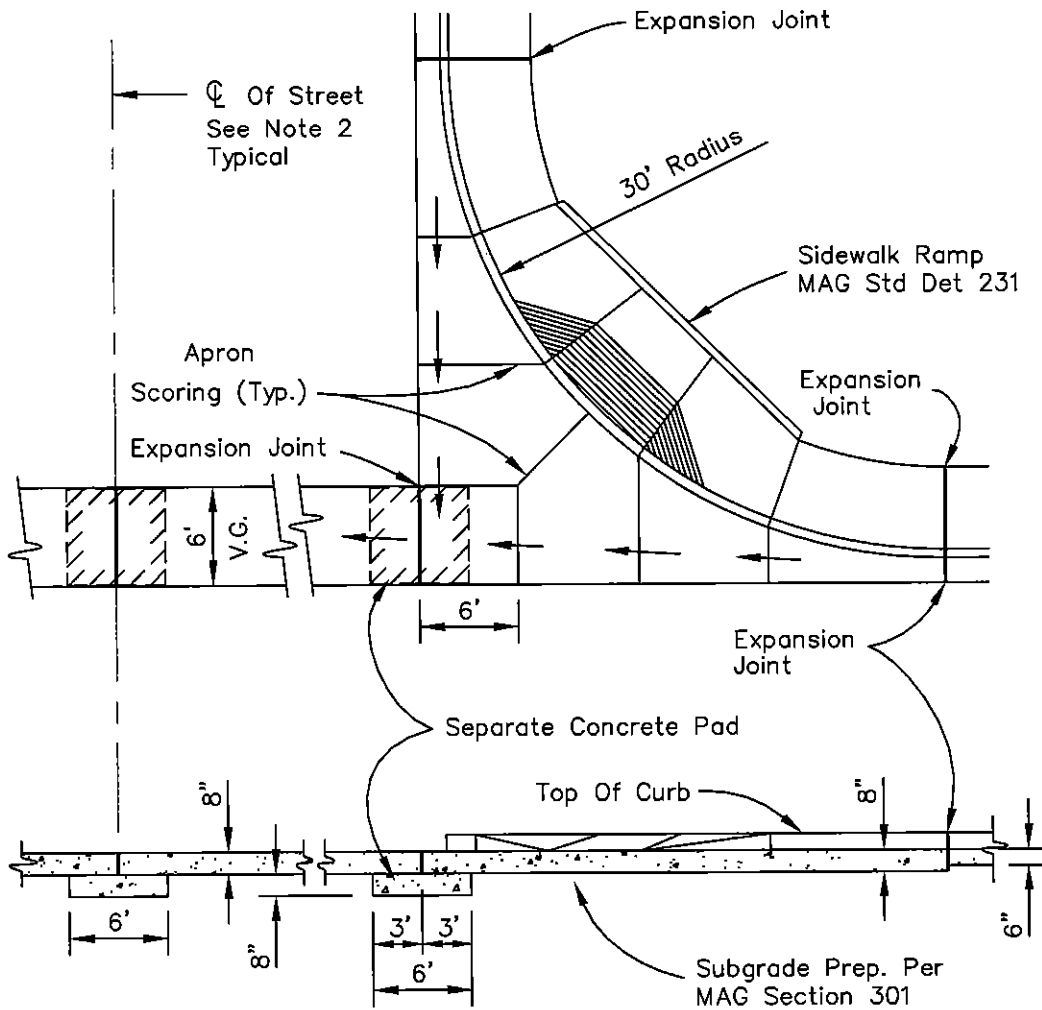

SECTION THRU APRON FLOW-LINE

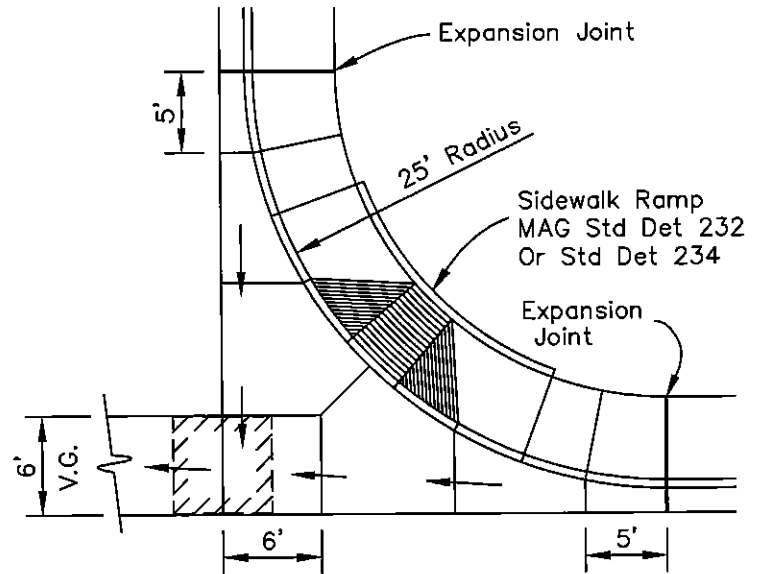

NOTES

1. All Concrete To Be Class "A", MAG Section 725.
2. Use A Construction Joint Or Contraction Joint At The \O Of Street. A Separate Concrete Pad Is Required With A Construction Joint.
3. $\frac{1}{2}$ " Expansion Joint, ASTM D-1751 Per MAG Section 729.
4. Return Curb and Sidewalk to be Monolithically Poured.

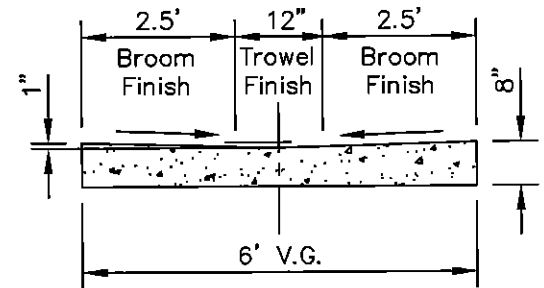

SECTION THRU VALLEY GUTTER

DETAIL NO. **2240** City of Scottsdale
Standard Details

6' VALLEY GUTTER & APRON

DETAIL NO. **2240**

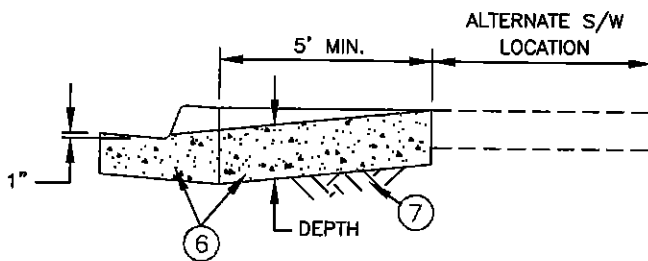
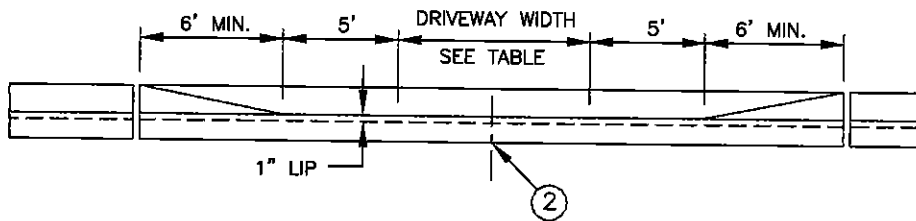
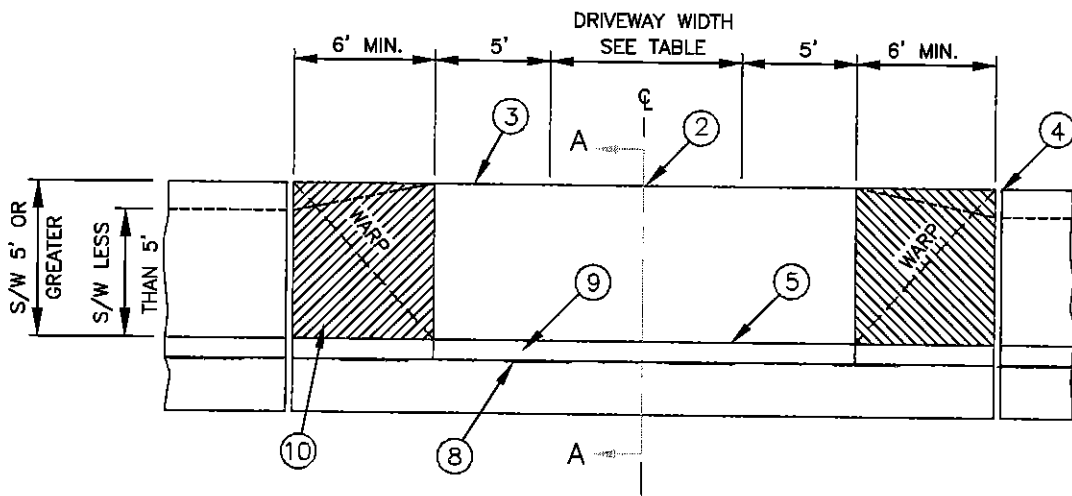

SECTION A-A

NOTES

1. DEPRESSED CURB SHALL BE PAID FOR AT THE UNIT PRICE BID FOR THE TYPE OF CURB USED AT THAT LOCATION.
2. CONTRACTION JOINT ON DRIVEWAY CENTERLINE.
3. BACK OF DRIVEWAY ENTRANCE OR FUTURE SIDEWALK.
4. MASTIC EXPANSION JOINT THROUGH CURB AND GUTTER. EXPANSION JOINT FILLER SHALL BE 1/2" BITUMINOUS TYPE PREFORMED EXPANSION JOINT FILLER A.S.T.M. D-1751.
5. BACK OF CURB - CONSTRUCTION JOINT OR SCORE MARK.
6. CLASS 'B' CONCRETE, MAG SECTION 725.
7. SUBGRADE PREPARATION, MAG SECTION 301.
8. FLOW LINE OF GUTTER.
9. DEPRESSED CURB.
10. 1/4" GROOVES AT 1" ON CENTER FULL WIDTH OF 6' WARP SECTION, EACH SIDE OF DRIVEWAY. SEE DETAIL A, COS DETAIL 2232.

COMMERCIAL & INDUSTRIAL				
DRIVEWAY WIDTH	MIN.	MAX.	CLASS	DEPTH
COMMERCIAL ZONING	+ 16'	40'	B	8"
INDUSTRIAL ZONING	+ 16'	40'	B	8"
+ 24' MIN. FOR TWO WAY TRAFFIC				
RESIDENTIAL				
DRIVEWAY WIDTH	MIN.	MAX.	CLASS	DEPTH
MAJOR STREET	16'	30'	B	8"
COLLECTOR STREET	*12'	30'	B	8"
LOCAL STREET	12'	30'	B	8"
* 16' DESIRABLE				

DETAIL NO. **2250** City of Scottsdale
Standard Details

DRIVEWAY ENTRANCES

DETAIL NO. **2250**

REVISED 4/7/00

CONSTRUCTION NOTES

1. Sidewalk shall conform to MAG Standard Detail 230 and C.O.S. Sec. 340.
2. Curb as called for on plans.
3. Curb & Gutter shall conform to MAG Standard Detail 220. Single Curb shall conform to MAG Standard Detail 222.
4. Driveway Entrances shall conform to COS Standard Detail 2250. Driveways shall be 2-1/2" A.C. R-19 on 6" A.B.C. unless otherwise noted. See plans for driveway limits.
5. Valley Gutter shall conform to COS Standard Detail 2240.
6. Sidewalk Ramps shall conform to MAG Standard Detail 232, minimum 8" thick.
7. Curb termination similar to MAG Std. Det 222.
8. When installing new driveways along an existing street, sawcut, remove & replace a minimum 2' wide strip of A.C. pavement per COS Standard Detail 2200.

S-1

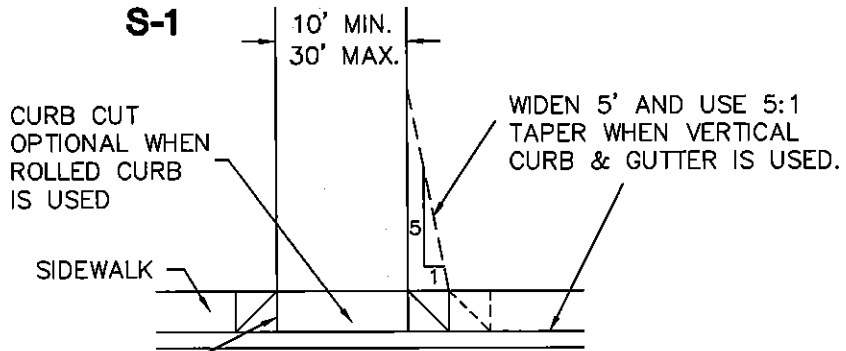

See Note 4 **SINGLE FAMILY UNIT**

M-1

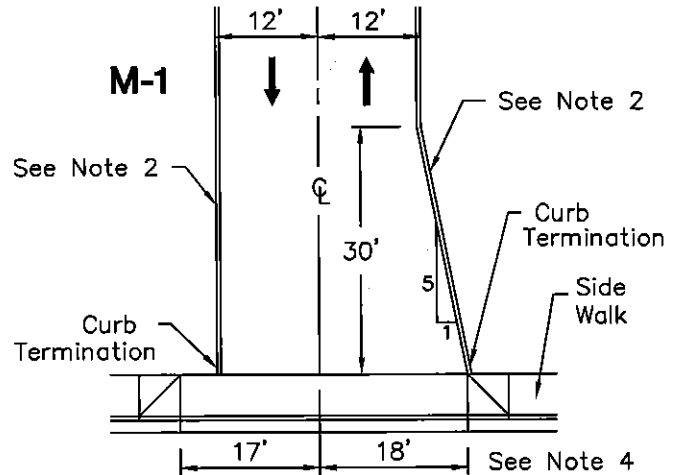

MULTI FAMILY UNITS

M-2

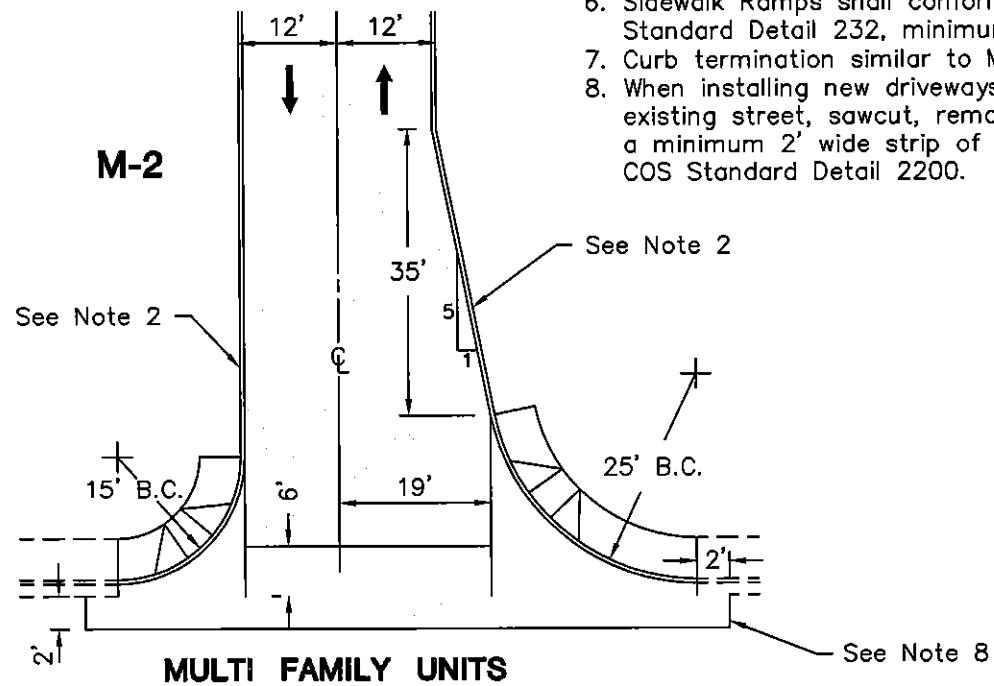

MULTI FAMILY UNITS

DETAIL NO.
2255

**City of Scottsdale
Standard Details**

RESIDENTIAL DRIVEWAYS

DETAIL NO.
2255

REVISED 4/7/00

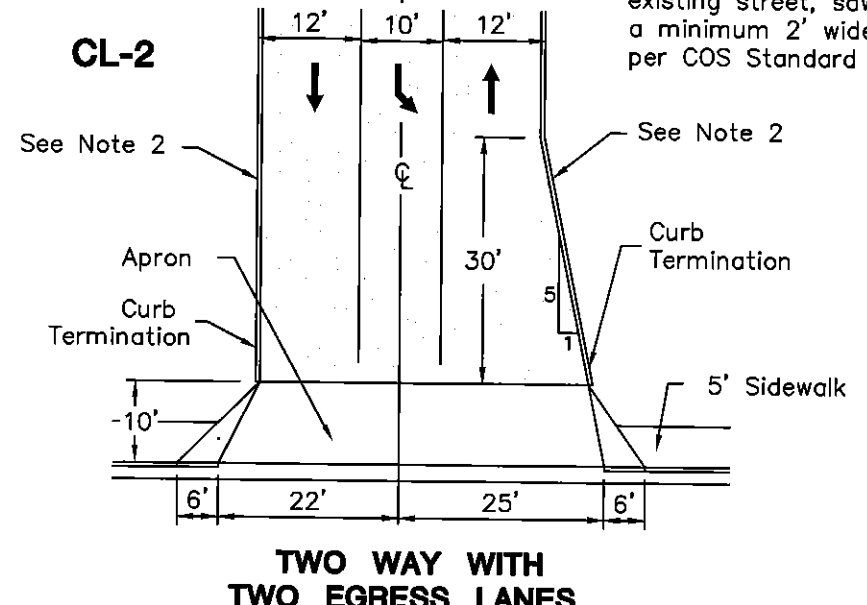
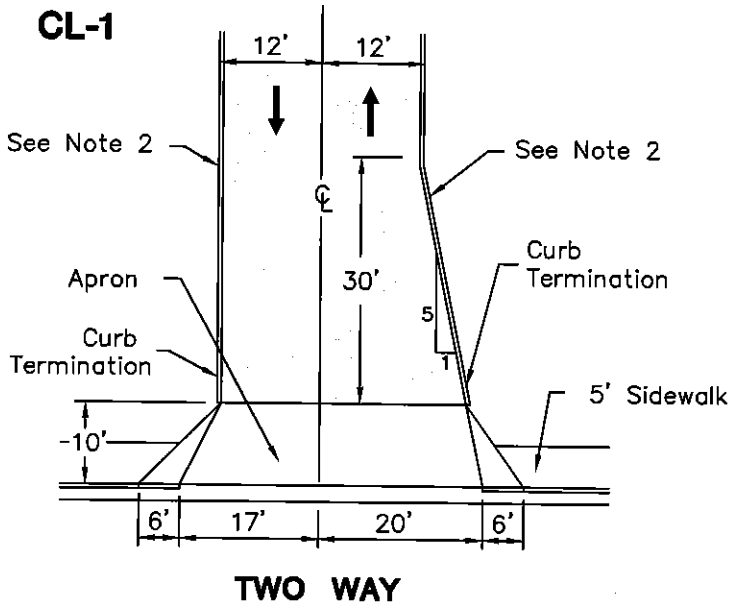
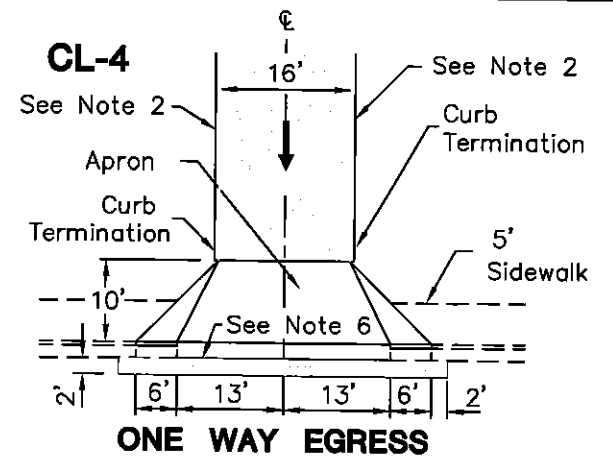
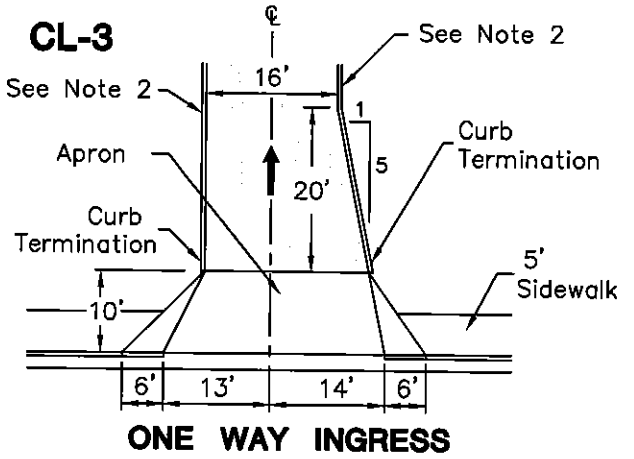

CONSTRUCTION NOTES

1. Sidewalk shall conform to MAG Standard Detail 230 and C.O.S. Sec. 340.
2. Curb as called for on plans.
3. Curb & Gutter shall conform to MAG Standard Detail 220. Single Curb shall conform to MAG Standard Detail 222.
4. Driveway Entrances shall conform to COS Standard Detail 2250 except for modifications as noted. Driveways shall be 2-1/2" A.C. A-19 on 6" A.B.C. unless otherwise noted. See plans for driveway limits.
5. Curb termination similar to MAG Std. Det. 222.
6. When installing new driveways along an existing street, sawcut, remove & replace a minimum 2' wide strip of A.C. pavement per COS Standard Detail 2200.

DETAIL NO. **2256** City of Scottsdale Standard Details

COMMERCIAL/INDUSTRIAL DRIVEWAYS-TYPE CL

DETAIL NO. **2256**

REVISED 4/7/00

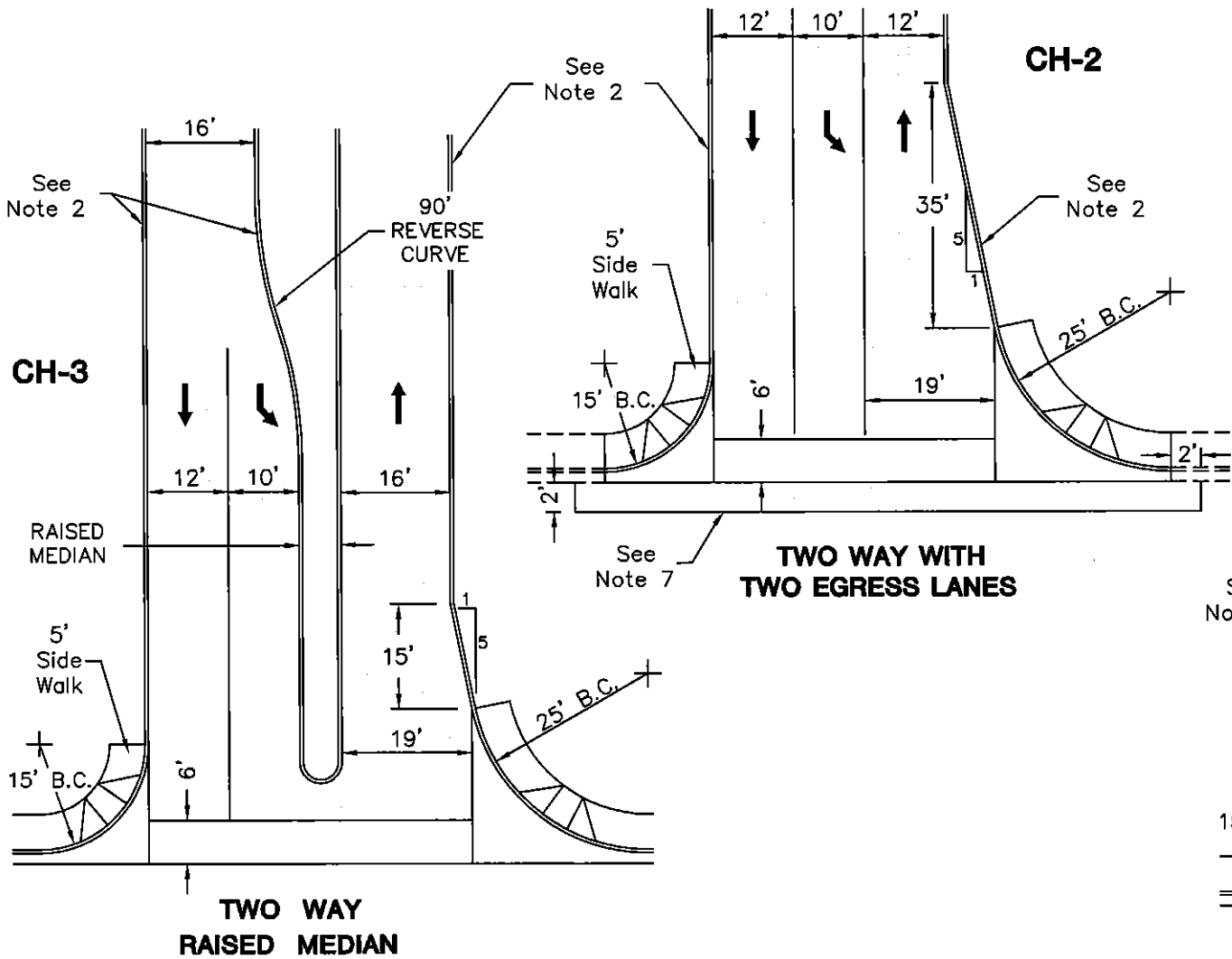

CONSTRUCTION NOTES

1. Sidewalk shall conform to MAG Standard Standard Detail 230 and C.O.S. Sec. 340.
2. Curb as called for on plans.
3. Curb & Gutter shall conform to MAG Standard Detail 220. Single Curb shall conform to MAG Standard Detail 222.
4. Driveways shall be 2-1/2" A.C. A-19 on 6" A.B.C. unless otherwise noted. See plans for driveway limits.
5. Valley Gutter shall conform to COS Standard Detail 2240.
6. Sidewalk Ramps shall conform to MAG Standard Detail 232, Minimum 8" Thick.
7. When installing new driveways along an existing street, sawcut, remove & replace a minimum 2' wide strip of A.C. pavement per COS Standard Detail 2200.

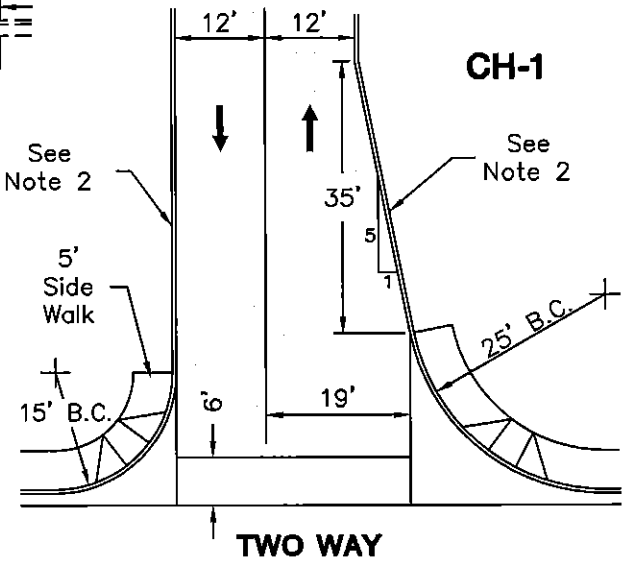

DETAIL NO. **2257** City of Scottsdale Standard Details

COMMERCIAL/INDUSTRIAL DRIVEWAYS-TYPE CH

DETAIL NO. **2257**

REVISED 4/1/00

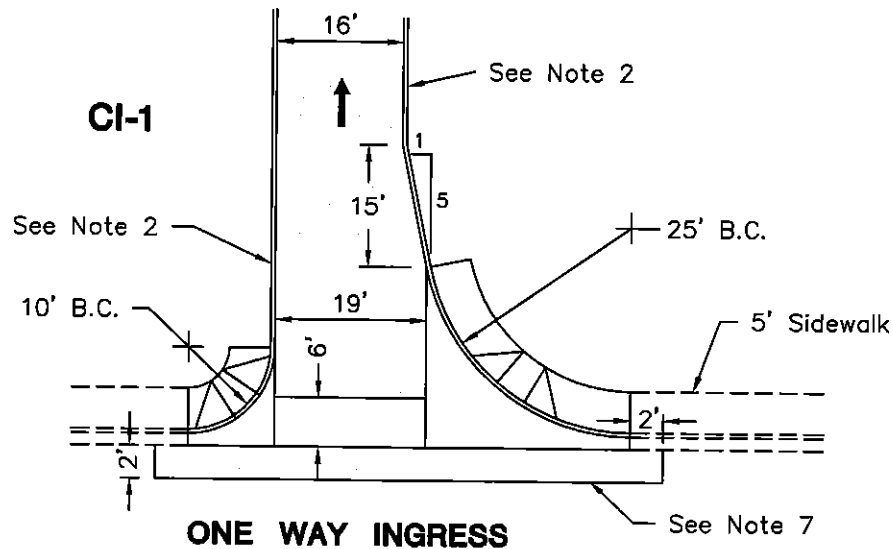

CONSTRUCTION NOTES

1. Sidewalk shall conform to MAG Standard Standard Detail 230 and C.O.S. Sec. 340.
2. Curb as called for on plans.
3. Curb & Gutter shall conform to MAG Standard Detail 220. Single Curb shall conform to MAG Standard Detail 222.
4. Driveways shall be 2-1/2" A.C. A-19 on 6" A.B.C. unless otherwise noted. See plans for driveway limits.
5. Valley Gutter shall conform to COS Standard Detail 2240.
6. Sidewalk Ramps shall conform to MAG Standard Detail 232, Minimum 8" Thick.
7. When installing new driveways along an existing street, sawcut, remove & replace a minimum 2' wide strip of A.C. pavement per COS Standard Detail 2200.

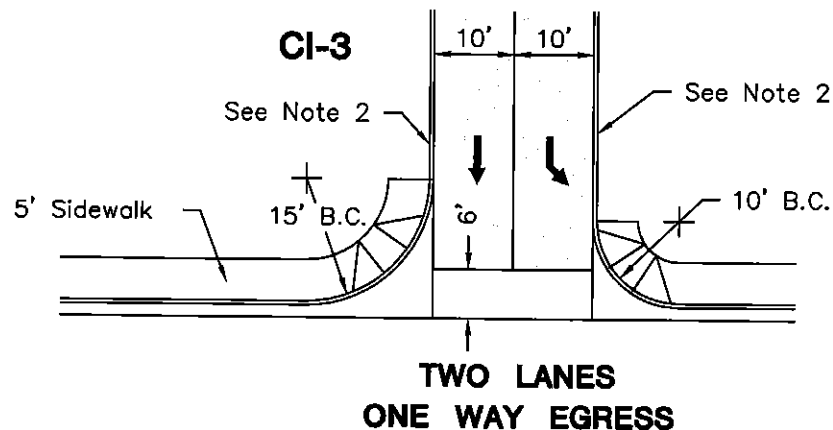
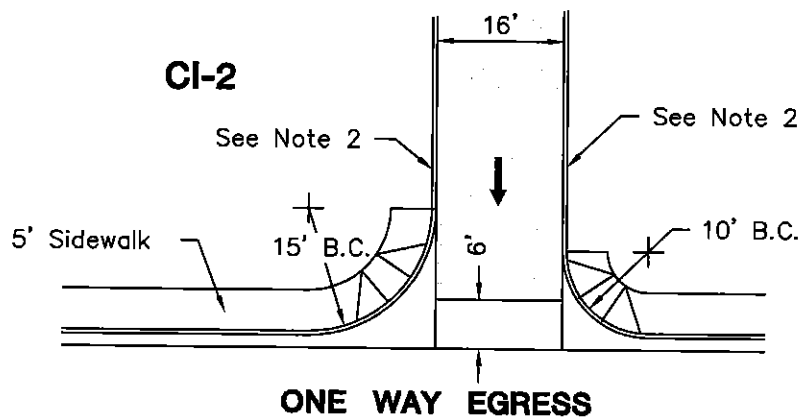

DETAIL NO. **2258** City of Scottsdale
Standard Details

COMMERCIAL/INDUSTRIAL DRIVEWAYS-TYPE CI

DETAIL NO. **2258**

REVISED 3/17/99

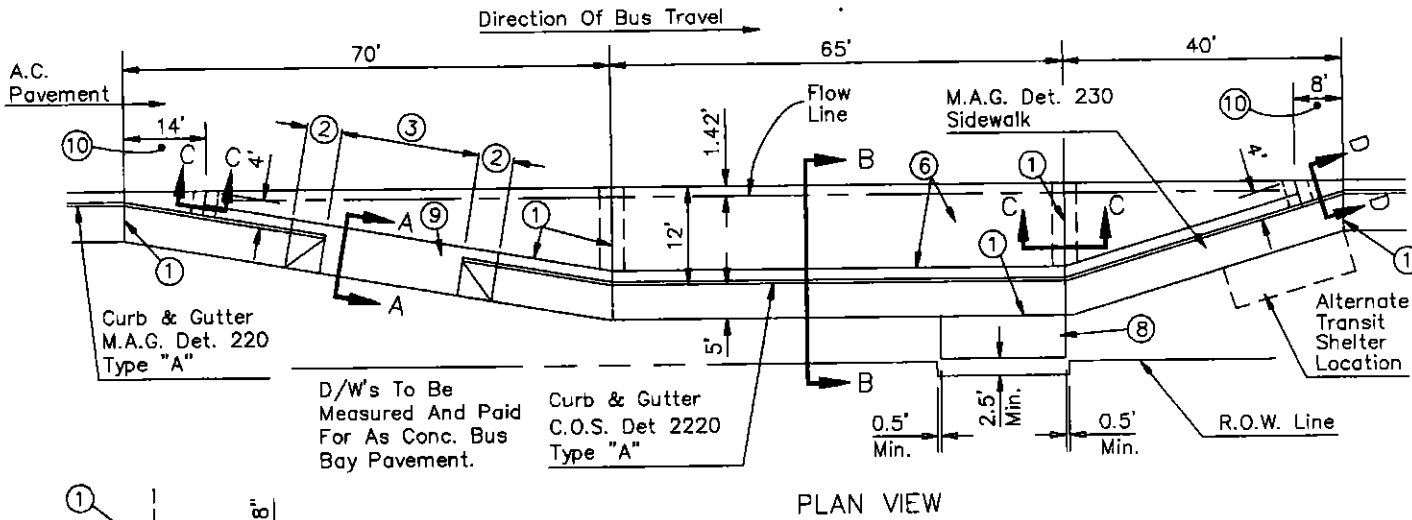

- ① 1/2" BITUMINOUS PREFORMED EXPANSION JOINT FILLER, A.S.T.M. D-1751 PER MAG SEC. 729, INSTALL PER COS SEC. 340.3.
- ② TRANSITION CURB FACE FROM 6" TO 0" HEIGHT IN 5'
- ③ D/W WIDTHS & LOCATIONS VARY, SEE PLANS. MAINTAIN 10' MIN. CLEARANCE BETWEEN DRIVEWAYS AND SHELTER PAD. WHEN DRIVEWAY WIDTH EXCEEDS 22', PROVIDE A CONTRACTION JOINT ON D/W C.
- ④ SUBGRADE PREPARATION PER MAG SECTION 301.
- ⑤ CONCRETE PAD TO BE POURED SEPARATELY FROM CONCRETE BUS BAY PAVEMENT.
- ⑥ CONTRACTION JOINTS IN THE BUS BAY PAVEMENT SHALL MATCH THOSE IN THE CURB.
- ⑦ CONCRETE SHALL BE CLASS "A" PER MAG SECTION 725
- ⑧ TRANSIT SHELTER PAD, PER COS STD DETAIL 2269.
- ⑨ NEW CONCRETE D/W TO BE POURED WITH BUS BAY PAVEMENT.
- ⑩ CURB & GUTTER TO BUS BAY PAVEMENT TRANSITION.

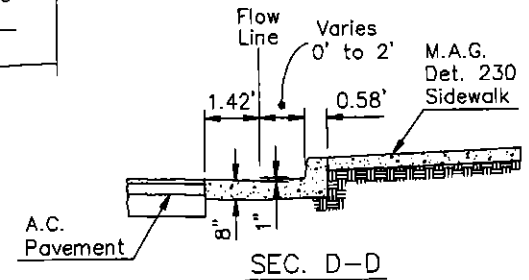
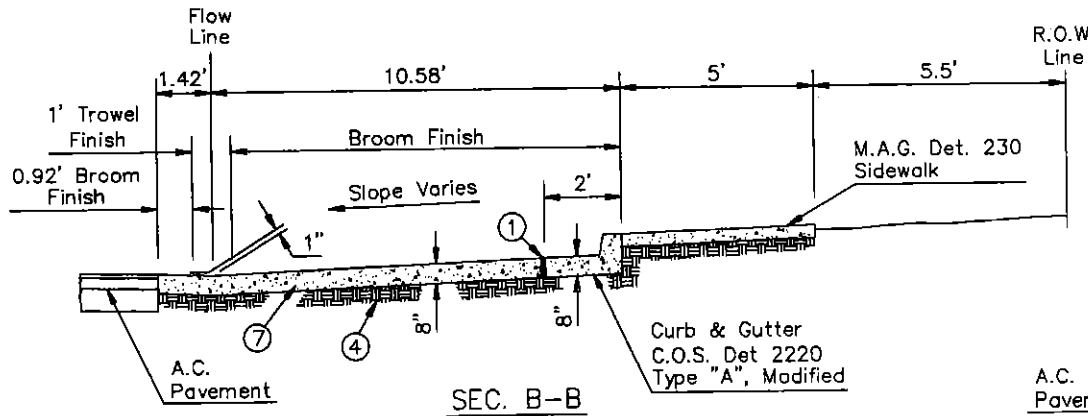
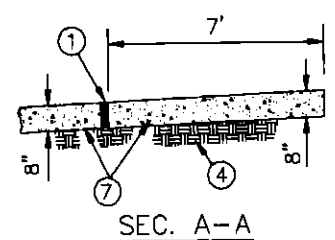
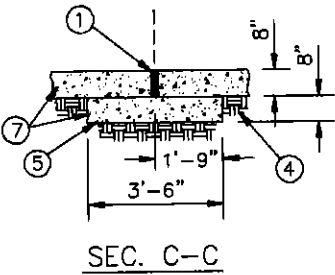

DETAIL NO. **2266-1** City of Scottsdale Standard Details

APPROVED BY:
Scottsdale Standards & Specifications Committee

MID-BLOCK BUS BAY - TYPE 'A'

DETAIL NO. **2266-1**

REVISED 1/4/93

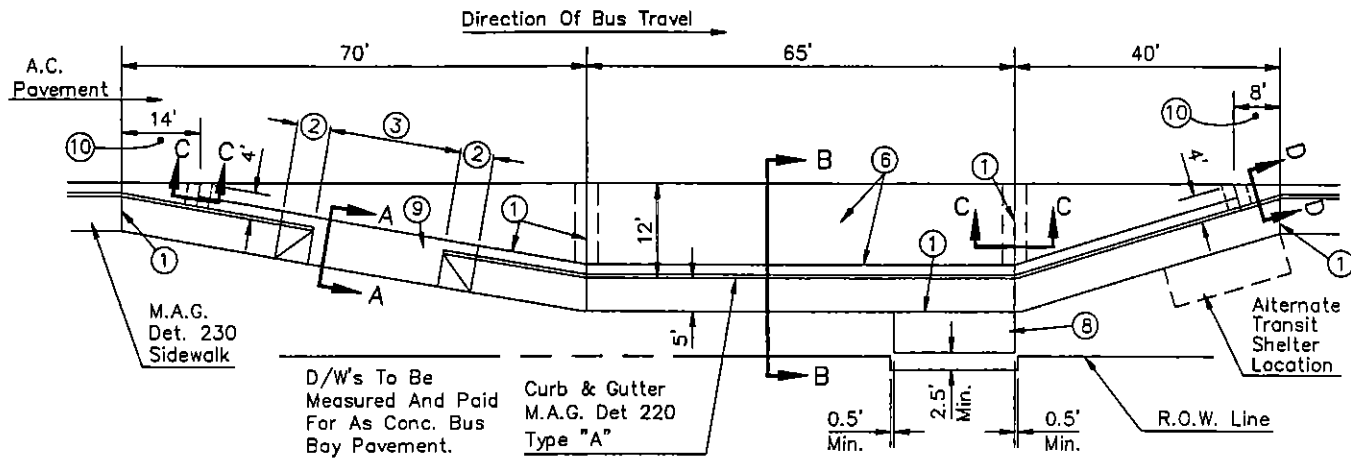

PLAN VIEW

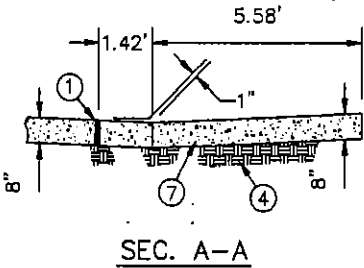

SEC. A-A

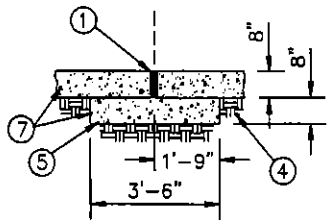

SEC. C-C

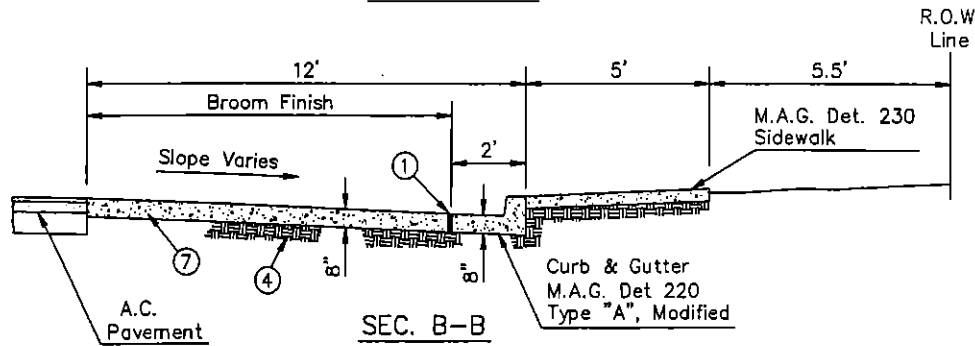

SEC. B-B

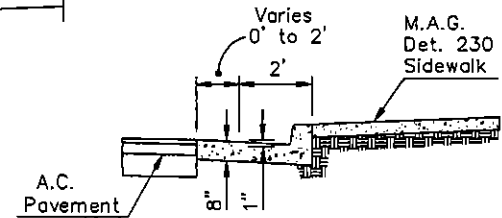

SEC. D-D

- ① 1/2" BITUMINOUS PREFORMED EXPANSION JOINT FILLER, A.S.T.M. D-1751 PER MAG SECTION 729.
- ② TRANSITION CURB FACE FROM 6" TO 0" HEIGHT IN 5'
- ③ D/W WIDTHS & LOCATIONS VARY, SEE PLANS. MAINTAIN 10' MIN. CLEARANCE BETWEEN DRIVEWAYS AND SHELTER PAD. WHEN DRIVEWAY WIDTH EXCEEDS 22', PROVIDE A CONTRACTION JOINT ON D/W ϕ .
- ④ SUBGRADE PREPARATION PER MAG SECTION 301.
- ⑤ CONCRETE PAD TO BE POURED SEPARATELY FROM CONCRETE BUS BAY PAVEMENT.
- ⑥ CONTRACTION JOINTS IN THE BUS BAY PAVEMENT SHALL MATCH THOSE IN THE CURB.
- ⑦ CONCRETE SHALL BE CLASS "A" PER MAG SECTION 725
- ⑧ TRANSIT SHELTER PAD, PER COS STD DETAIL 2269.
- ⑨ NEW CONCRETE D/W TO BE POURED WITH BUS BAY PAVEMENT.
- ⑩ CURB & GUTTER TO BUS BAY PAVEMENT TRANSITION.

DETAIL NO. **2266-2** City of Scottsdale Standard Details

APPROVED BY: 

MID-BLOCK BUS BAY - TYPE "B"

DETAIL NO. **2266-2**

REVISED 1/4/93

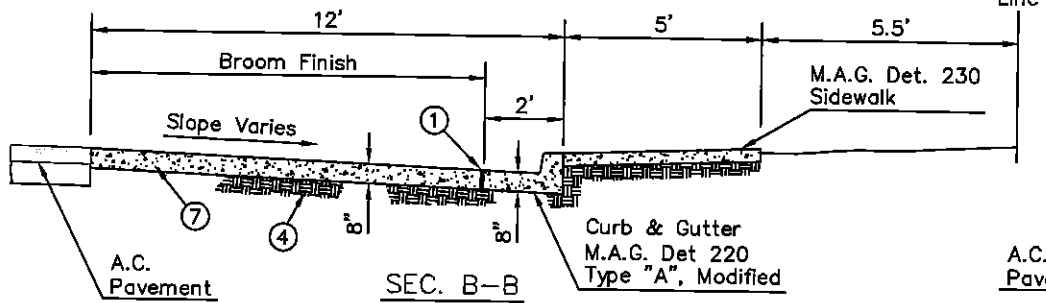
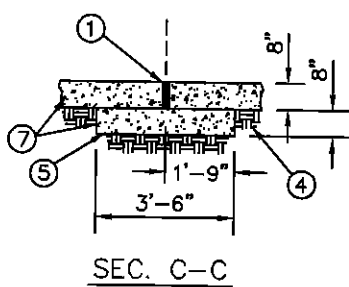
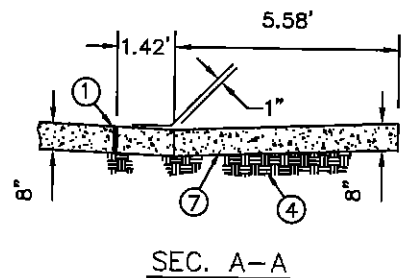
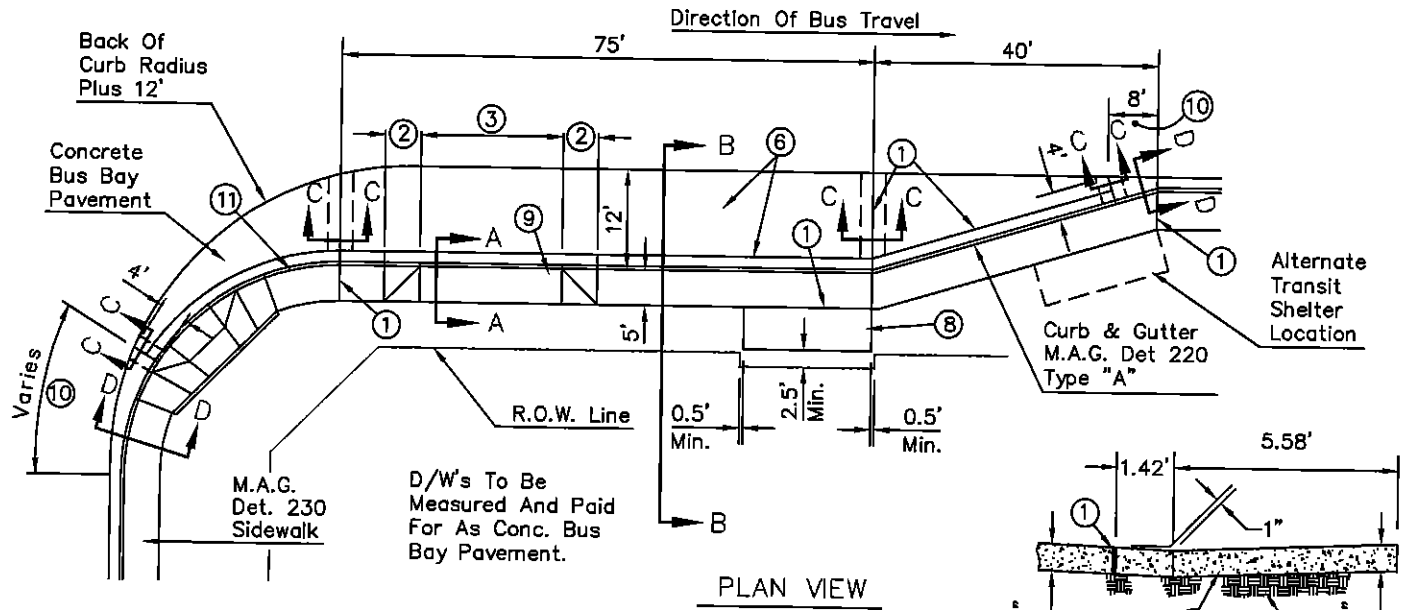

- ① 1/2" BITUMINOUS PREFORMED EXPANSION JOINT FILLER, A.S.T.M. D-1751 PER MAG SECTION 729.
- ② TRANSITION CURB FACE FROM 6" TO 0" HEIGHT IN 5'
- ③ D/W WIDTHS & LOCATIONS VARY, SEE PLANS. MAINTAIN 10' MIN. CLEARANCE BETWEEN DRIVEWAYS AND SHELTER PAD. WHEN DRIVEWAY WIDTH EXCEEDS 22', PROVIDE A CONTRACTION JOINT ON D/W ϕ .
- ④ SUBGRADE PREPARATION PER MAG SECTION 301.
- ⑤ CONCRETE PAD TO BE POURED SEPARATELY FROM CONCRETE BUS BAY PAVEMENT.
- ⑥ CONTRACTION JOINTS IN THE BUS BAY PAVEMENT SHALL MATCH THOSE IN THE CURB.
- ⑦ CONCRETE SHALL BE CLASS "A" PER MAG SECTION 725
- ⑧ TRANSIT SHELTER PAD, PER COS STD DETAIL 2269.
- ⑨ NEW CONCRETE D/W TO BE POURED WITH BUS BAY PAVEMENT.
- ⑩ CURB & GUTTER TO BUS BAY PAVEMENT TRANSITION.
- ⑪ CURB RADIUS AS SHOWN ON THE PLANS

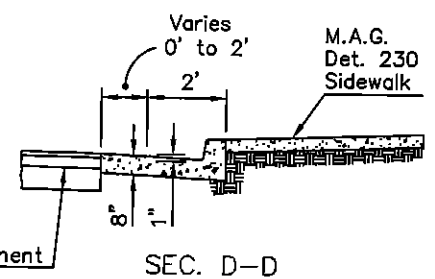

DETAIL NO. **2267** City of Scottsdale Standard Details

APPROVED BY: _____

FAR - SIDE BUS BAY

DETAIL NO. **2267**

REVISED 7/1/97

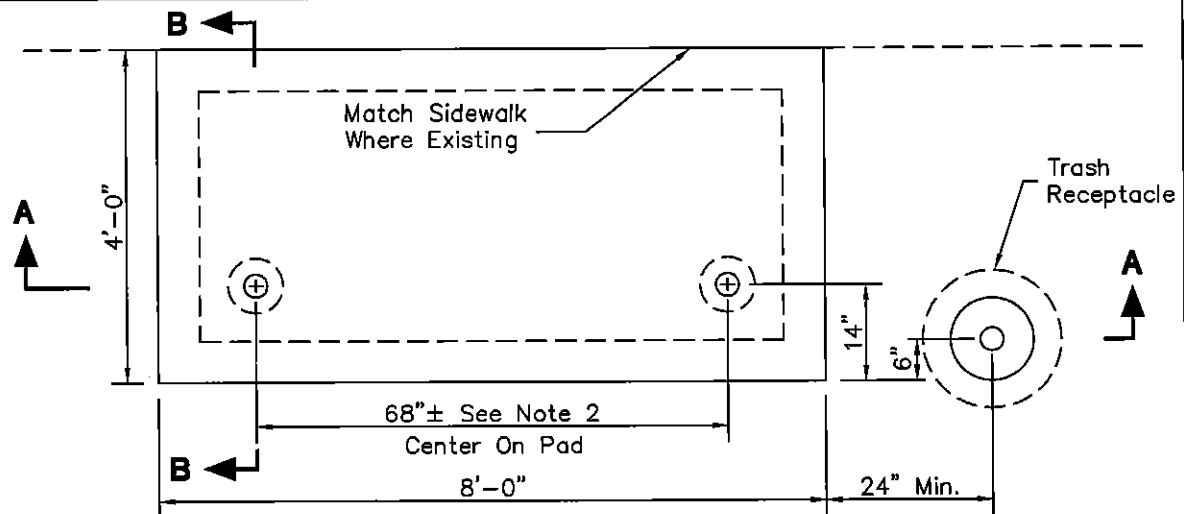

BASE SLAB PLAN

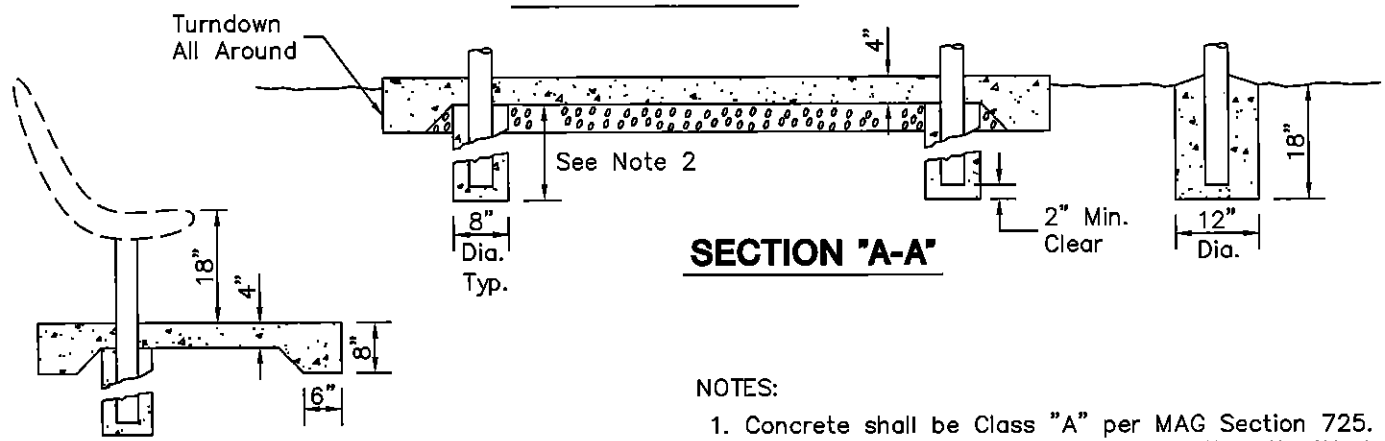

SECTION 'A-A'

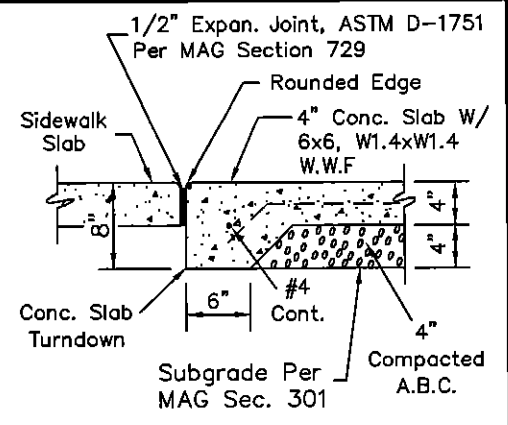

SLAB EDGE AT SIDEWALK

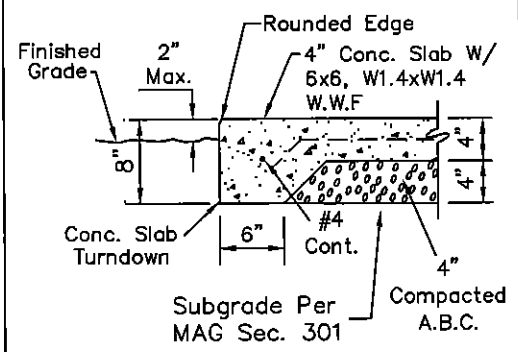

SLAB EDGE AT GRADE

NOTES:

1. Concrete shall be Class "A" per MAG Section 725. Slab surface shall be trowel finish with salt pitted appearance and random sweat. Use integral color when specified on the plans.
2. Dimensions may vary with bench style - Verify and adjust to provide clearance and bench height shown.

DETAIL NO. **2268** City of Scottsdale Standard Details

APPROVED BY: _____

BASE SLAB AND FOUNDATIONS FOR BUS STOP BENCH AND RECEPTACLES

DETAIL NO. **2268**

REVISED 7/1/97

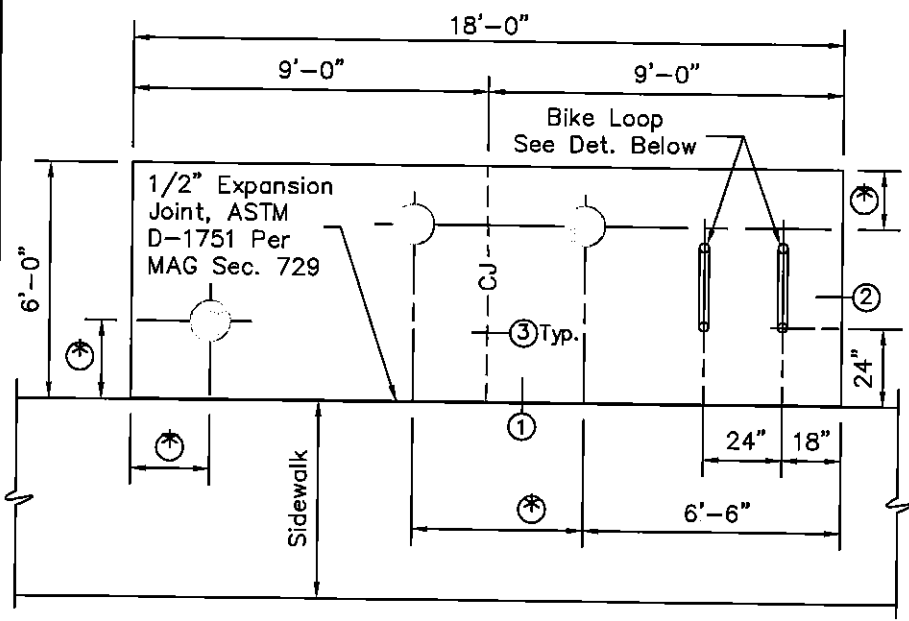

SHELTER SLAB PLAN

NOTES:

1. Concrete shall be Class "A" per MAG Sec. 725. Slab surface shall be trowel finish with salt pitted appearance and random sweat. Use integral color when specified on the plans.
2. "⊙" Blockout locations for bench and trash receptacle as shown on Plans or specified by the Engineer.

LEGEND

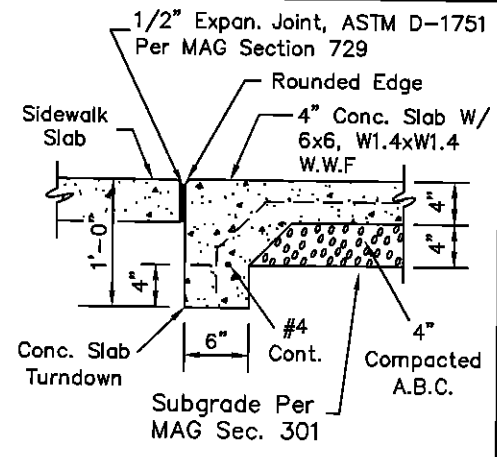
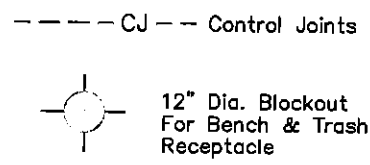

① SLAB EDGE AT SIDEWALK

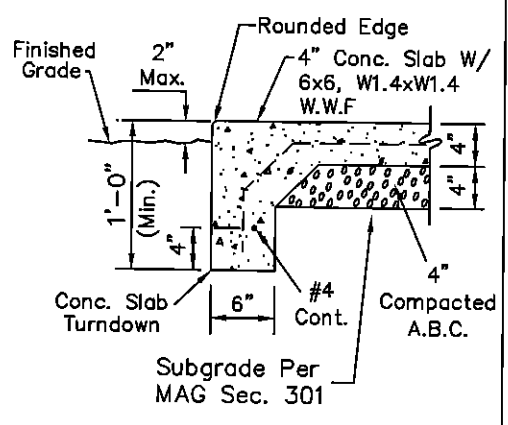

② SLAB EDGE AT GRADE

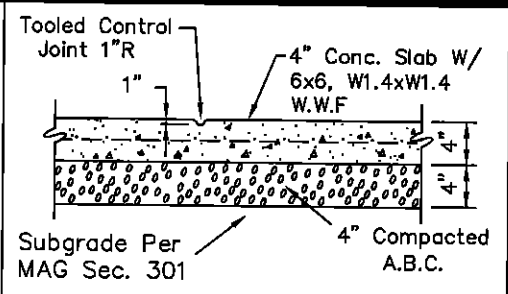

③ SLAB CONTROL JOINTS

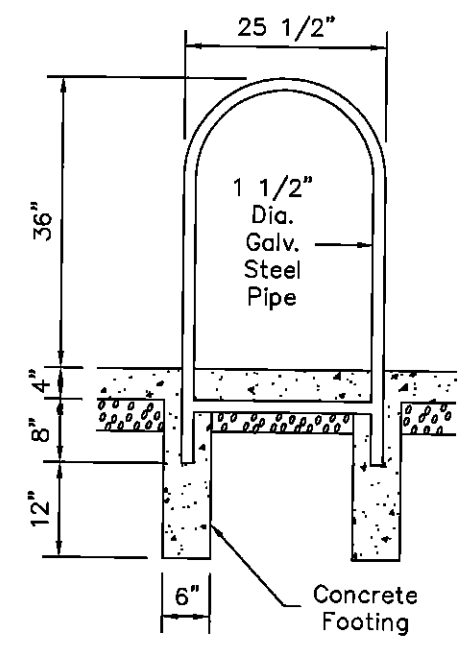

BIKE LOOP DETAIL

DETAIL NO. **2269** City of Scottsdale Standard Details

APPROVED BY: _____

TRANSIT SHELTER PAD

DETAIL NO. **2269**

REVISED 2/27/01

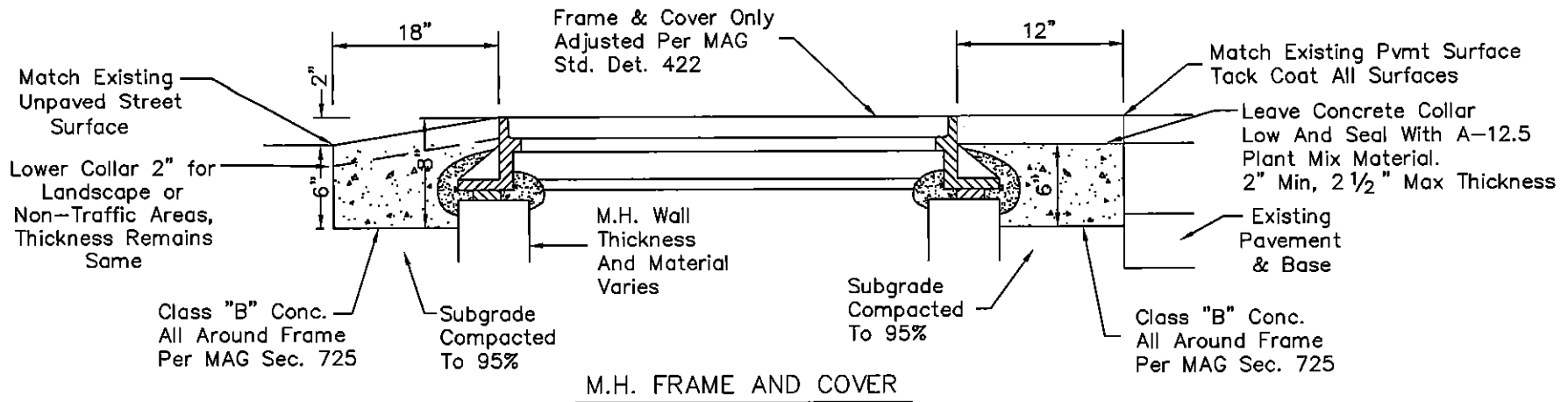

UNPAVED LOCATIONS

PAVED LOCATIONS

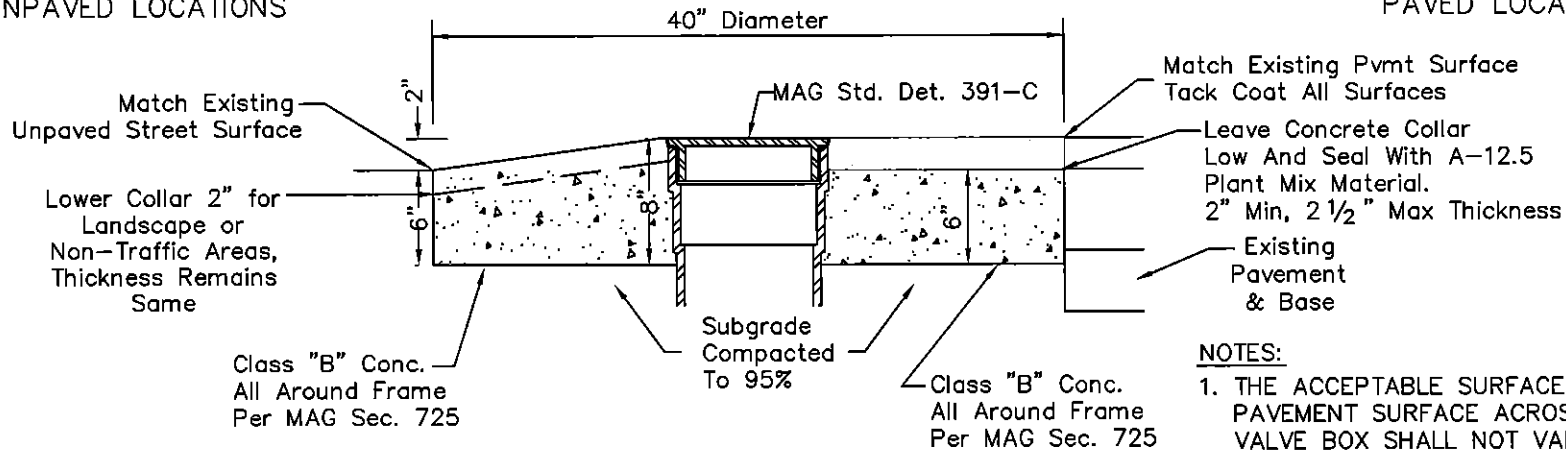

NOTES:

1. THE ACCEPTABLE SURFACE PROFILE FROM THE PAVEMENT SURFACE ACROSS THE MANHOLE OR VALVE BOX SHALL NOT VARY MORE THAN 1/4 INCH FROM THE LOWER EDGE OF A 12 FOOT STRAIGHTEDGE WHEN THE STRAIGHTEDGE IS PLACED PARALLEL AND PERPENDICULAR TO THE CENTERLINE OF THE ROADWAY.

VALVE BOX FRAME AND COVER

DETAIL NO. 2270

City of Scottsdale
Standard Details

FRAME & COVER GRADE ADJUSTMENT

DETAIL NO. 2270

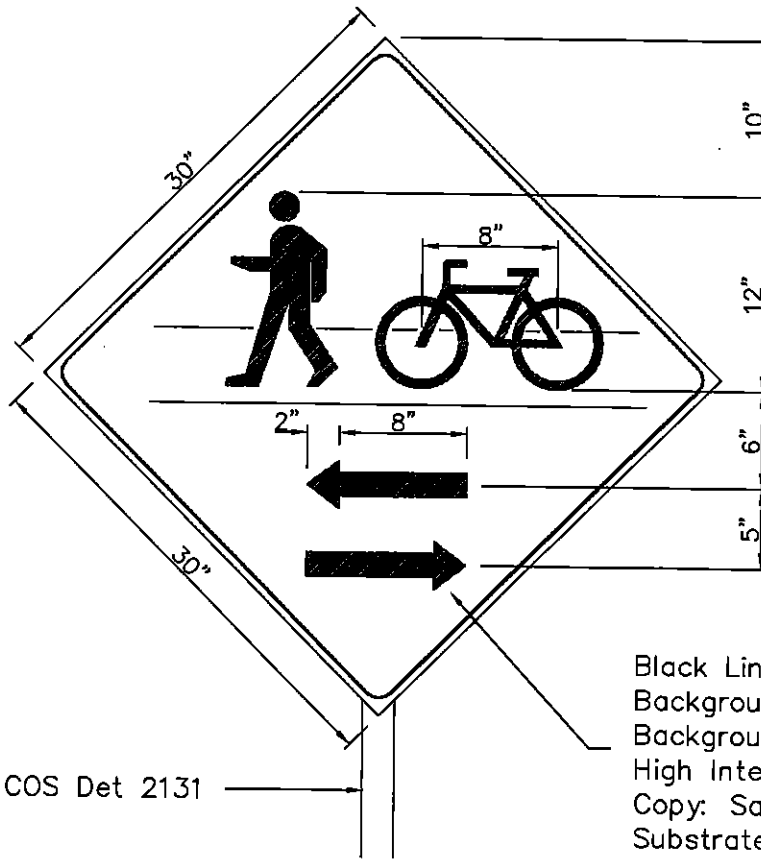

Install Per COS Det 2131

Black Lines On Yellow Reflectorized
Background (Typ.)
Background: Super Engineer Grade Or
High Intensity Sheeting
Copy: Same As Above
Substrate: 0.080 Gauge Treated Aluminum

MULTI-USE PATH CROSSING SIGN

DETAIL NO.
2281 City of Scottsdale
Standard Details

APPROVED BY:

MULTI-USE PATH CROSSING SIGN

DETAIL NO.
2281

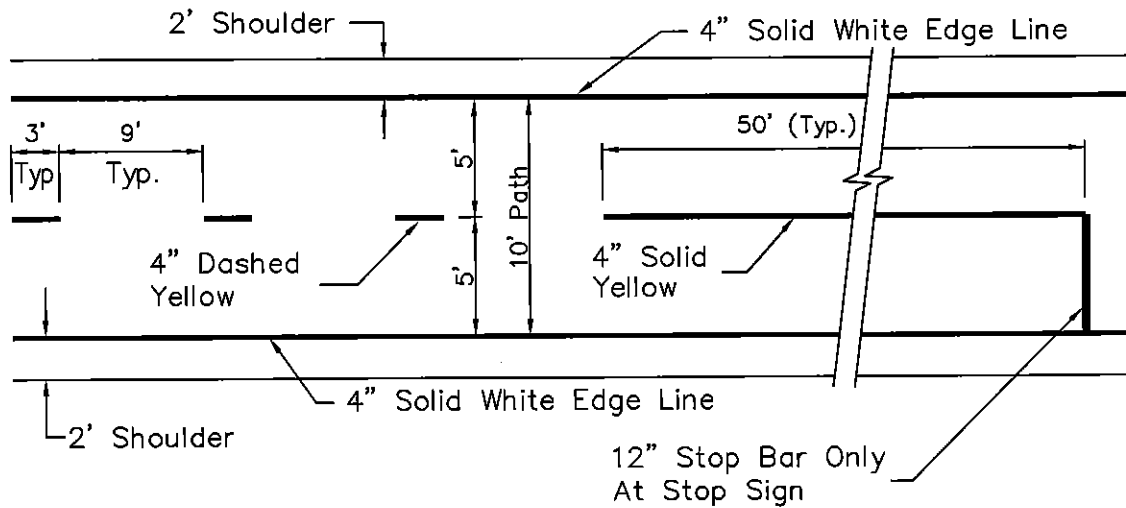

MULTI-USE PATH STRIPING DETAILS

NOTE:
 Striping shall be reflectorized paint with glass beads per COS Specifications Sec. 402.2

12" Stop Bar Only At Stop Sign

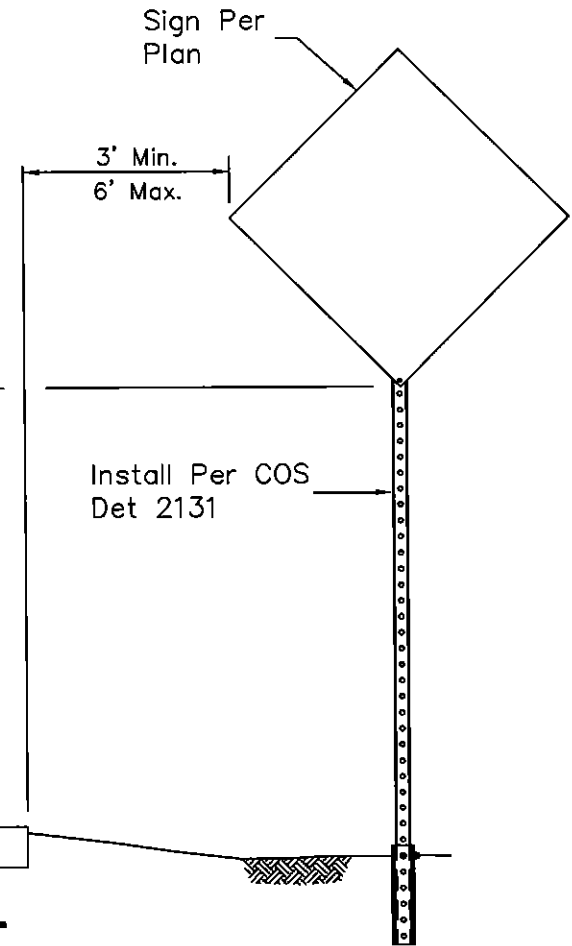

MULTI-USE PATH SIGN PLACEMENT

DETAIL NO. **2282** City of Scottsdale Standard Details

APPROVED BY: _____

MULTI-USE PATH STRIPING AND SIGNING

DETAIL NO. **2282**

* See Shoulder Detail

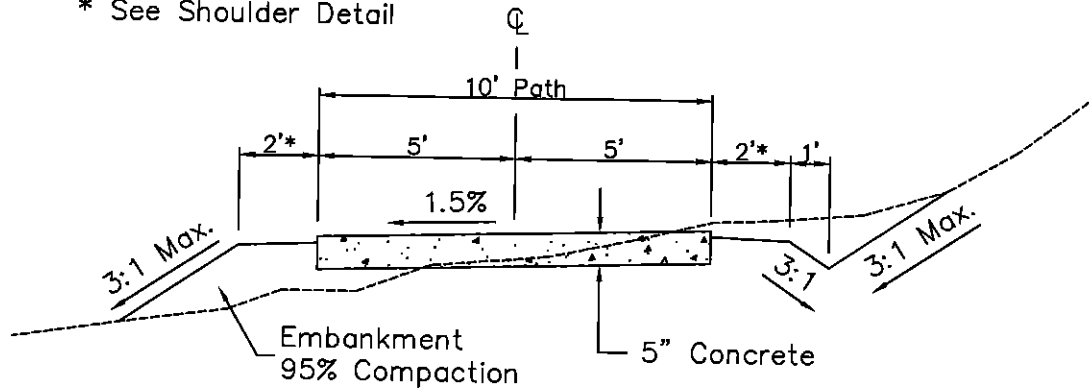

MULTI-USE PATH DETAIL

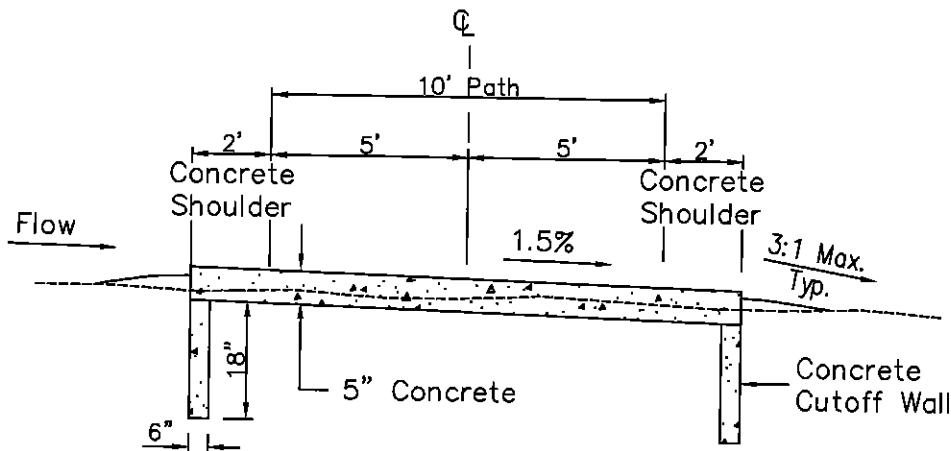

MULTI-USE PATH WET AREA CROSSING

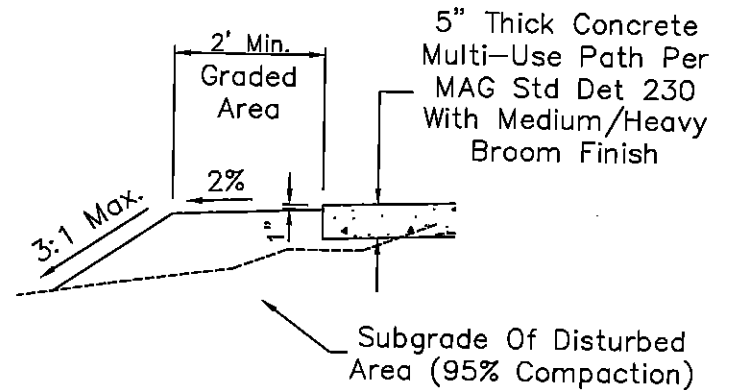

SHOULDER DETAIL

Note: A 3' x 3' Test Panel Shall Be Poured and the finish approved by COS Bicycle Staff At (480)312-7696.

DETAIL NO. **2283** City of Scottsdale
Standard Details

MULTI-USE PATH DETAILS

DETAIL NO. **2283**

REVISED: 2/26/01

NOTES:

1. Signs shall conform to C.O.S. Supplemental Specifications, Section 402.3.
2. Signs to be mounted on square perforated tubing per C.O.S. Std Det 2131 within C.O.S. Right-of-Way. Treated wood post may be used for trail markers located outside C.O.S. Right-of Way.
3. Legends and borders shall be vinyl sheeting on a reflectorized vinyl background (colors as noted) unless otherwise approved by the City of Scottsdale.
4. Sign height and placement shall conform to C.O.S. Std. Det. 2282.
5. For additional information regarding sign fabrication, contact the City of Scottsdale Sign Shop, 312-5646.

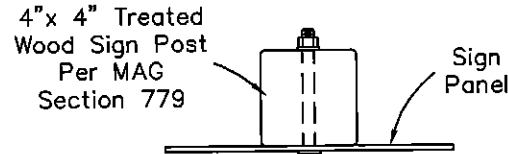
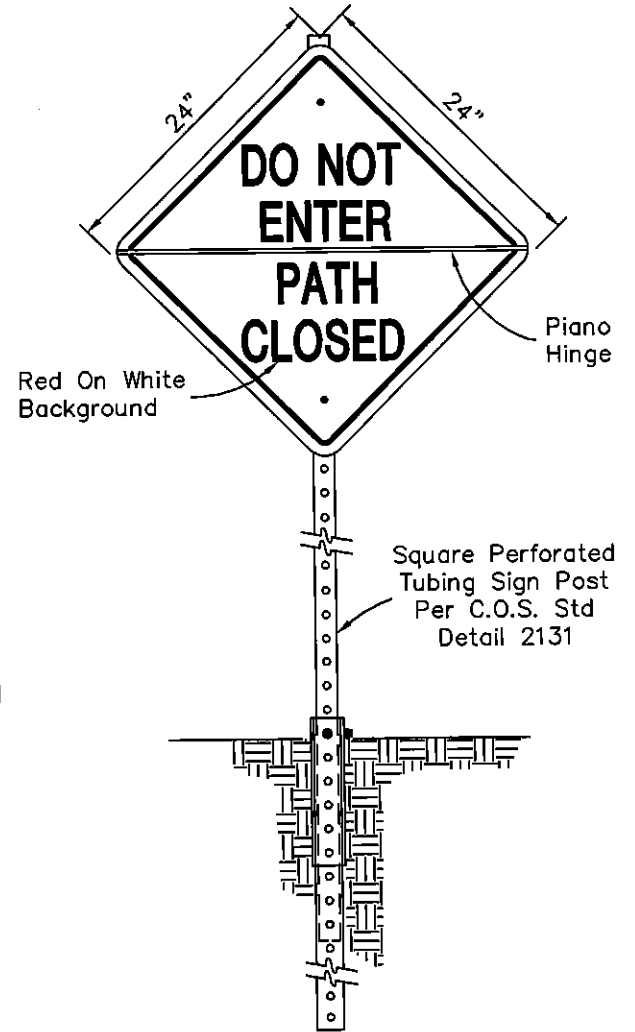
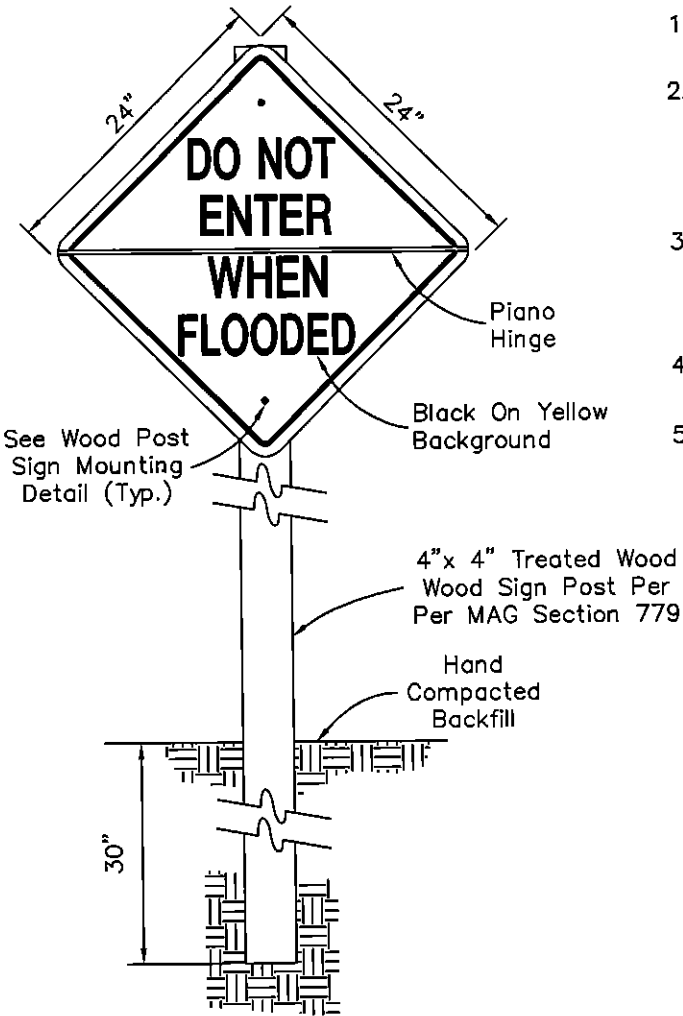

Fasten With (2) 1/2" x 2" Lag Screws With (2) Flat Washers or (2) 1/2" x 4 1/2" Bolts With (4) Flat Washers. Burr Threads And Nuts With Center Punch.

WOOD POST SIGN MOUNTING DETAIL

DETAIL NO. **2284** City of Scottsdale Standard Details

APPROVED BY: _____

MULTI-USE PATH WET CROSSING SIGN

DETAIL NO. **2284**

Upright Supports
1 1/2" O.D.
Steel Tubing,
11 Gauge
Weld To Base

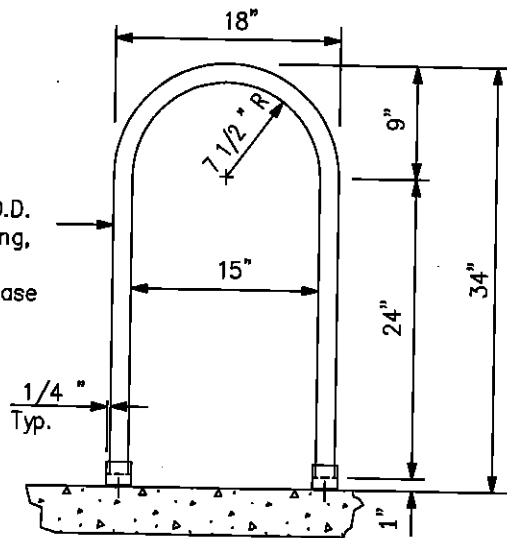

1/8" x 2" x 2" x 0'-2"
Angle Anchor Brackets
w/ 1/2" ϕ Hole. Weld
To Base. (4 Req'd)

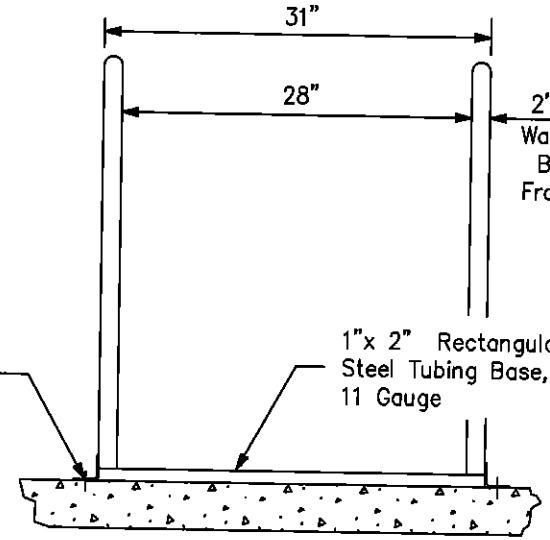

2' Min. Clearance From
Walls Or Obstructions On
Both Sides And Back.
Front To Have A 6' Min.
Clear Area.

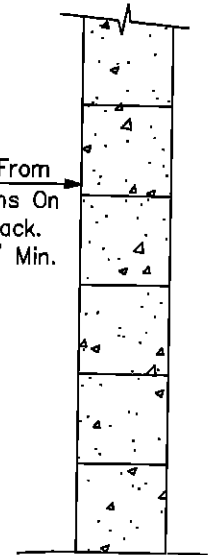

NOTES:

1. Double rack holds 4 bicycles.
2. Finish to be weather resistant, baked-on powder polymer coating.
3. Anchor rack to concrete w/ 3/8" ϕ x 2 1/2" wedge anchors, (4 Req'd) or set tubing 12" below grade in 24" deep x 6" wide concrete footing.
4. Concrete base may be covered with turf or decomposed granite.
5. Placement of bicycle rack shall be convenient to main entrance and in a highly visible area.

1/8" x 2" x 2" x 0'-2"
Angle Anchor Brackets
w/ 1/2" ϕ Hole. Weld
To Base. (4 Req'd)

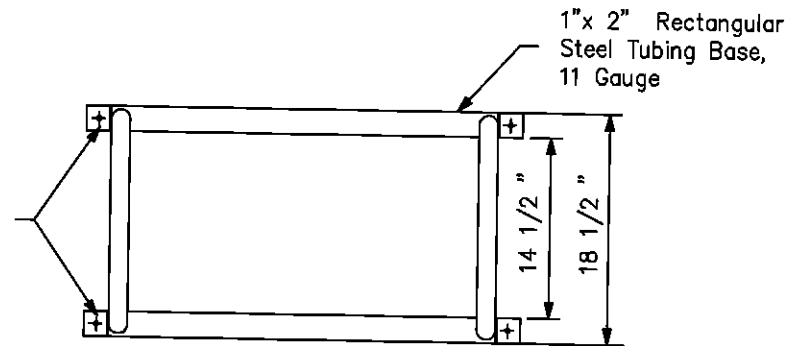

DETAIL NO.
2285

**City of Scottsdale
Standard Details**

APPROVED BY:

DOUBLE BICYCLE RACK

DETAIL NO.
2285

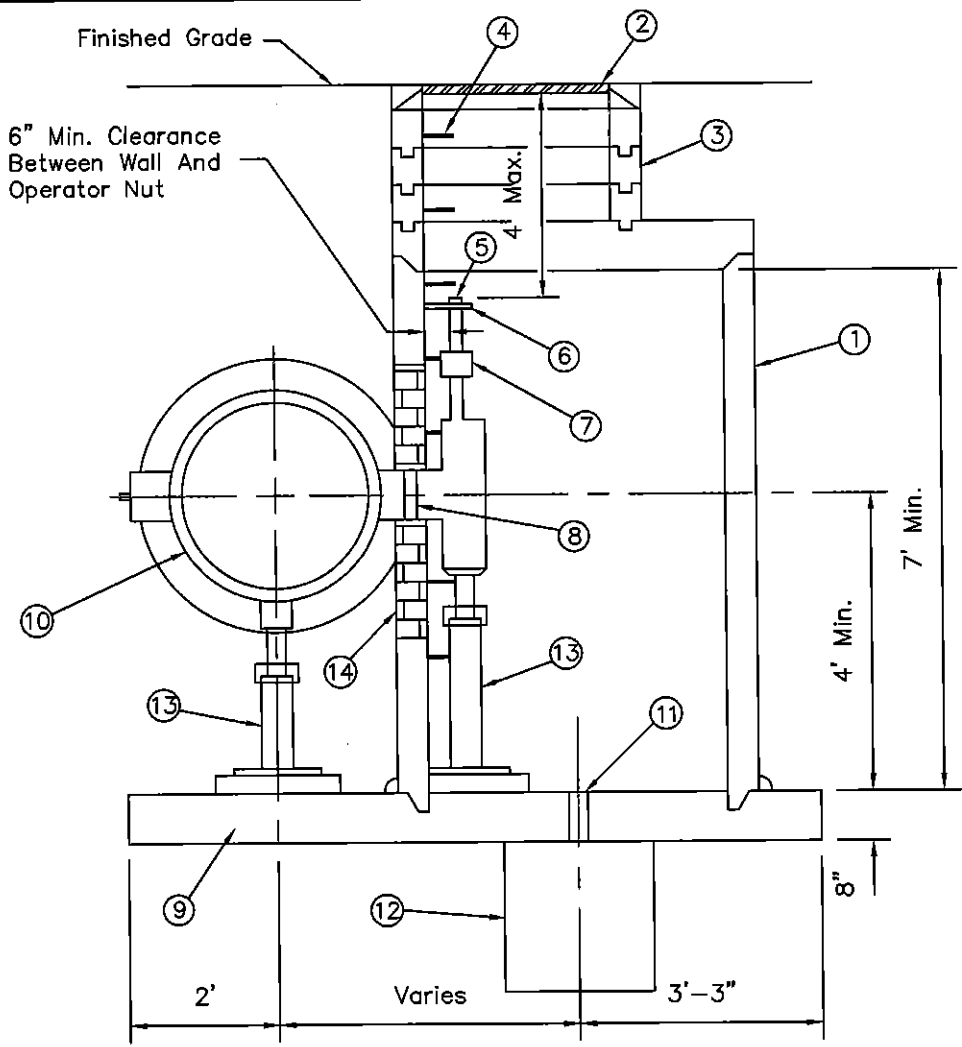

LEGEND

- ① 48" I.D. Manhole Shaft Per MAG Std. Detail 420, Type "B" Top
- ② 30" Manhole Frame & Cover Per MAG Std. Detail 424
- ③ Grouted Adjusting Rings
- ④ Polypropylene Manhole Steps Per MAG Std. Detail 428, 12" Spacing Typical
- ⑤ Operator Nut
- ⑥ Wall Bracket
- ⑦ Packing Gland
- ⑧ 6" Extension
- ⑨ #4 Rebar 12" On Center Each Way 2" Clear Typical
- ⑩ Butterfly Valve
- ⑪ 3" Diameter Drain
- ⑫ 8 Cu. Ft. Gravel Sump
- ⑬ Adjustable Pipe Saddle Support
- ⑭ Rectangular Cut-Out In Manhole Shaft, Fill Space Between Shaft And Pipe With 1" Sheet Foam, Brick And Mortar

SECTION

DETAIL NO. 2305-1	City of Scottsdale Standard Details	APPROVED BY: _____	<h1 style="margin: 0;">BUTTERFLY VALVE OPERATOR MANHOLE</h1>	DETAIL NO. 2305-1
-----------------------------	---	-----------------------	--	-----------------------------

REVISED 1/7/93

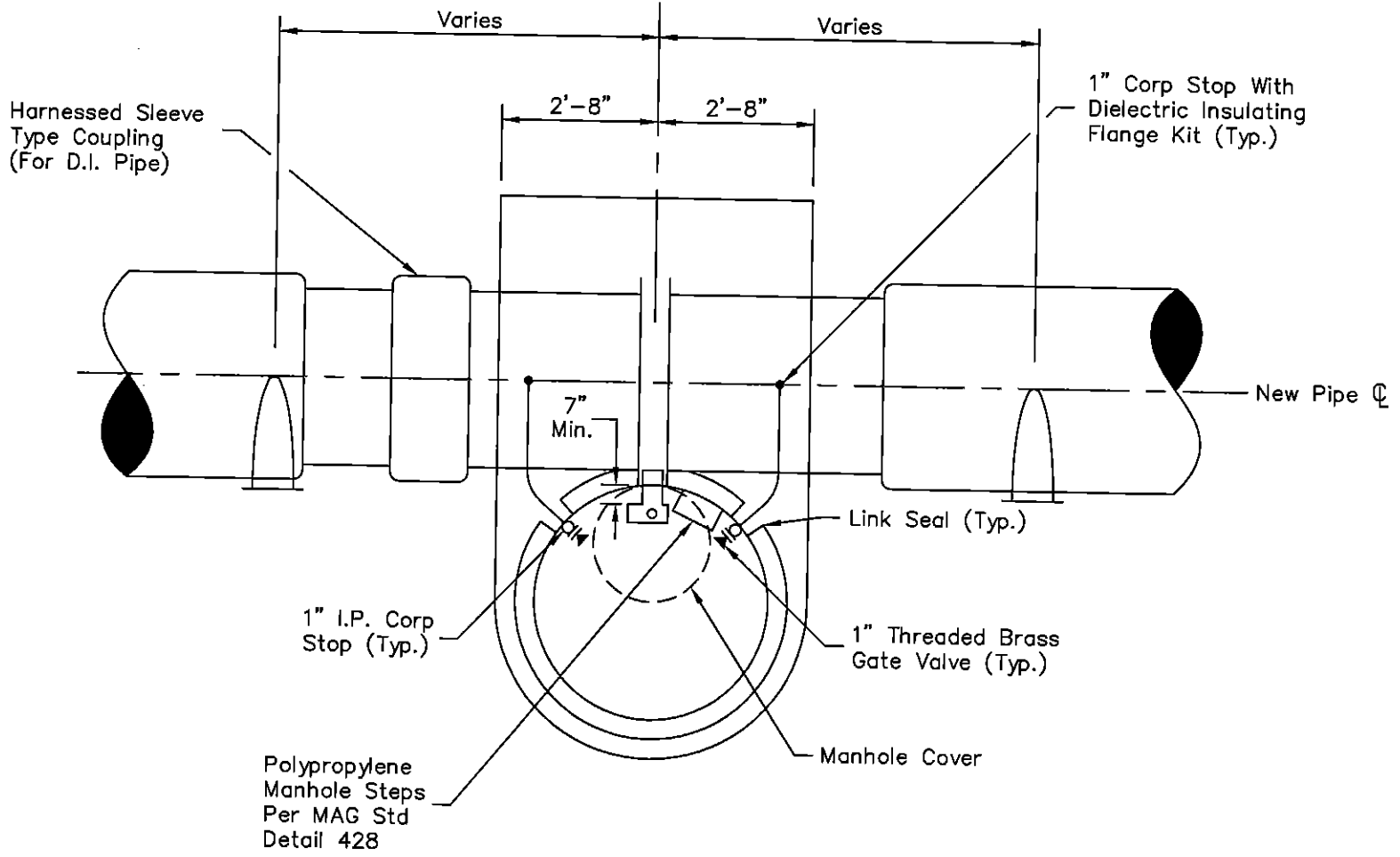

PLAN

DETAIL NO. **2305-2** City of Scottsdale
 Standard Details

APPROVED BY: _____

BUTTERFLY VALVE OPERATOR MANHOLE

DETAIL NO. **2305-2**

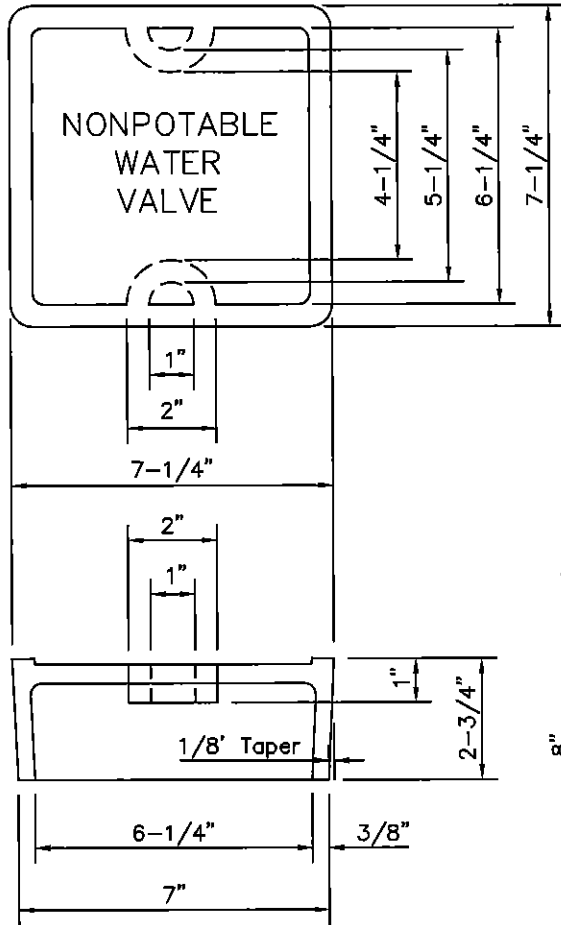

Class 'B' Conc. Collar
All Around Frame
Per MAG Sec. 725

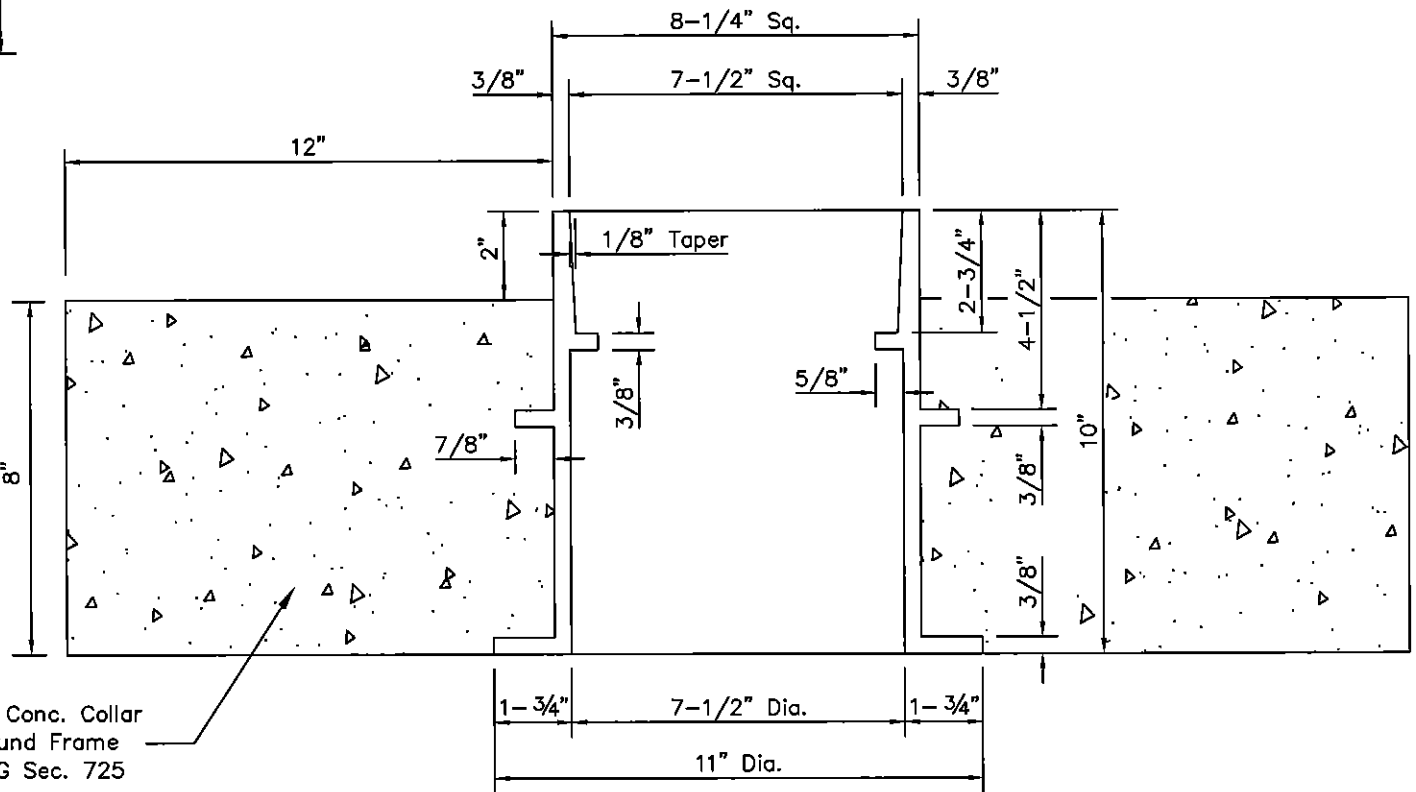

NOTES

1. Round bottom for riser pipe, square top for cover.
2. All materials shall be cast iron per ASTM A48, Class 30B.
3. Nonpotable water valve box to be installed per M.A.G. Std. Detail 391.
4. The cast iron lid shall be marked "Nonpotable Water Valve" on the top side. Letters shall be 1" each and raised 1/8".

DETAIL NO. **2315** **City of Scottsdale**
Standard Details

APPROVED BY: _____

NONPOTABLE WATER VALVE BOX & COVER

DETAIL NO. **2315**

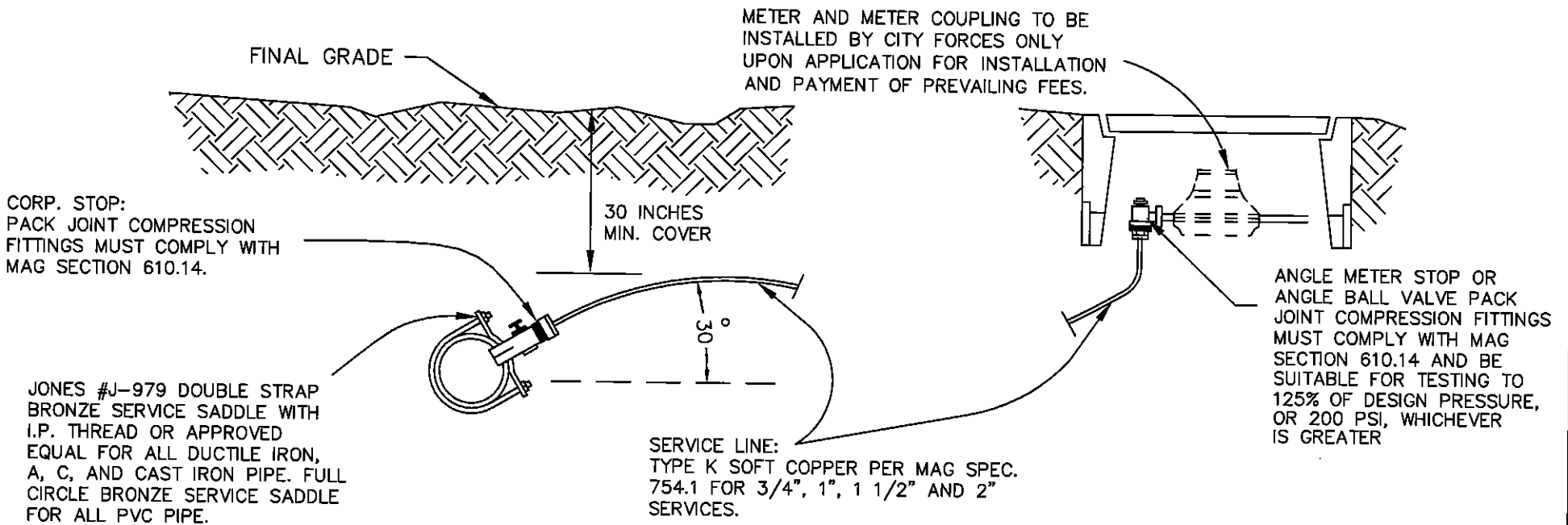

- NOTE:
1. All taps must be made using a service saddle.
 2. All service line sizes shall have the pack joint compression fittings for corp. stops and meter stops.
 3. Where a contractor is installing new water lines, he shall also install the water service connection. The installation shall include the service saddle, corp. stop, service pipe, appurtenant fittings, meter stop, concrete meter box and box cover, per M.A.G. Specifications.
 4. Copper service lines in the 3/4", 1", 1 1/2", and 2" sizes that cross streets will be one continuous piece. Only with the express written consent of Water & Wastewater Operations will joints be permitted under a road. When this occurs, pack joint fittings will be required; no soldered joints will be permitted.
 5. When all or part of a development is to be served by existing City of Scottsdale water mains, only authorized City of Scottsdale Water and Wastewater Operations personnel shall install the water service connection.

DETAIL NO. **2330** City of Scottsdale
Standard Details

WATER SERVICE LINE CONNECTION

DETAIL NO. **2330**

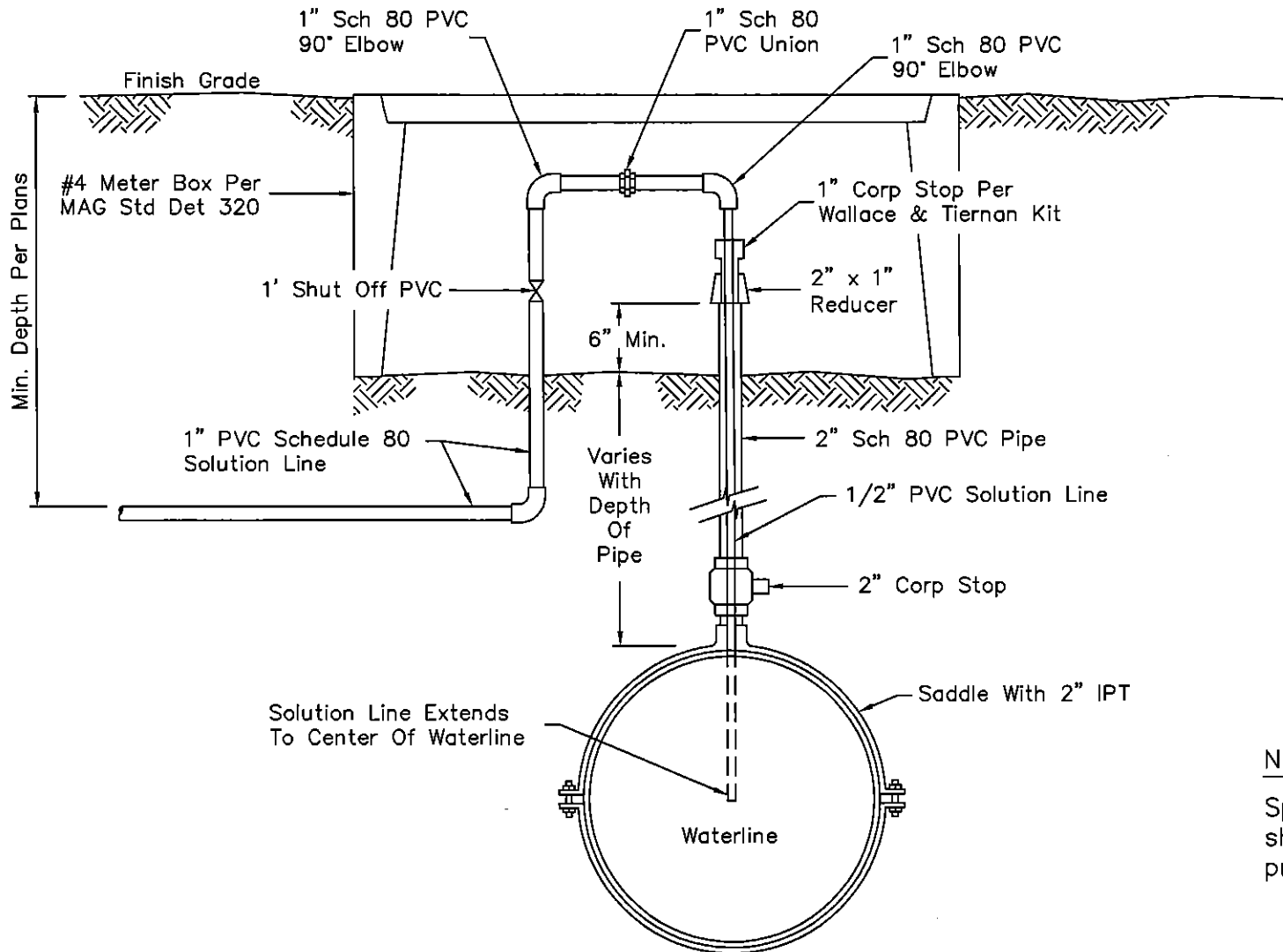

NOTE:

Specifications on all fittings shall exceed the maximum pressures of the system.

DETAIL NO.
2332

**City of Scottsdale
Standard Details**

APPROVED BY:

**CHLORINE INJECTION TAP
FOR UNDERGROUND WATERLINES**

DETAIL NO.
2332

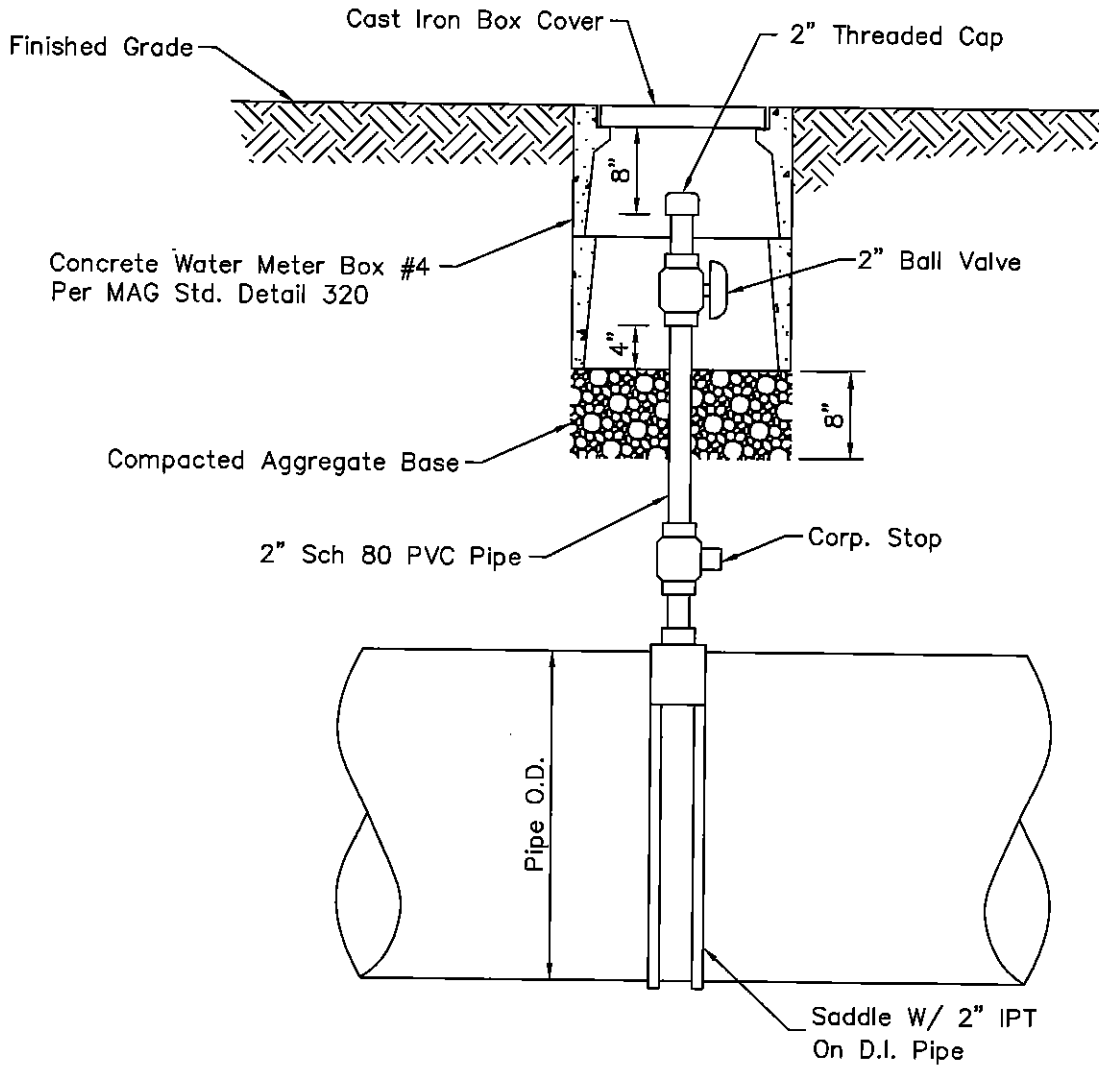

DETAIL NO.
2333

City of Scottsdale
Standard Details

APPROVED BY:

TAP FOR FUTURE CHLORINE INJECTION

DETAIL NO.
2333

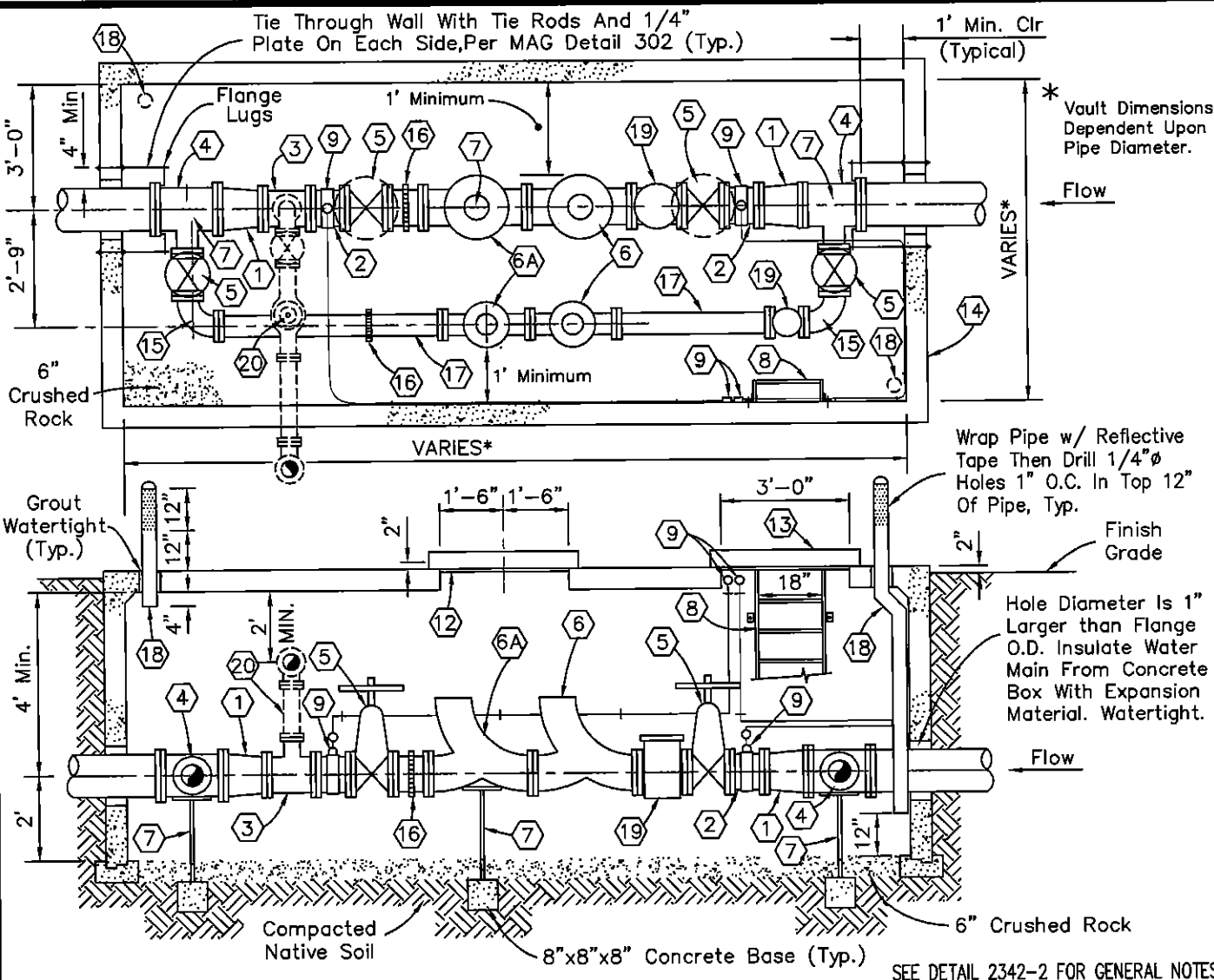

NOTES

- ① D.I.P. Fig Concentric Reducer
- ② D.I.P. Fig x Fig Spool Piece
- ③ D.I.P. Fig x Fig Tee. Install Only When Detail 2342-2 Is Used.
- ④ D.I.P. Fig Reducing Tee
- ⑤ Flg NRS Resilient Wedge Gate Valve, Inside Epoxy Coated, Low Zinc Stem w/ Wheel Handle
- ⑥ Flg PRV Bermad Model 723-20-V-I-U w/ Valve Position Indicator & Low Flow V-Port Plug And Must Have Stainless Steel Pilot Tubing, Or Approved Equal.
- ⑥A Flg PRV Bermad Model 723-20-V-I-U w/ Valve Or Approved Equal Will Be Installed When Pressure Differential Is 100 psi Or Greater.
- ⑦ 4" Dia Galv Adjustable Pipe Supports w/ 1" Adj. Rod And Nut On 8"x 8"x 8" Concrete Base.
- ⑧ Galv Access Ladder Bolted To Wall, 6" Stand Off.
- ⑨ Saddle With 1" Corp., 3/8" Brass Reducer, 3/8" 3/8" Brass Tee w/ Oil Filled 0-200 Pressure Gauge. Install 3/8" Stainless Tubing Strapped To Wall As Shown w/ Oil Filled Gauges Mounted At Access Door. Gages To Be Readable From Outside Vault.
- ⑫ For 8" Valves Or Larger Install Utility Vault Raised/ Adjustable Access Door, Model 3636, Or Approved Equal, Centered Over Main Valves For Removal.
- ⑬ Utility Vault Raised/Adjustable Steel Access Door For Inspection, Model 3636 Or Approved Equal. Place In Corner With Ladder.
- ⑭ Precast Concrete Water Utility Vault, Per MAG Std Det 321 & 345-1, Inside Dimensions Vary Depending On Pipe Size.
- ⑮ D.I.P. Fig 90° Elbow
- ⑯ Victaulic Coupling Or Approved Equal w/ All Thread Tie Rods.
- ⑰ D.I.P. Fig Pipe Spool
- ⑱ 4" Galv. Steel Vent Pipe With Cap. Strap Pipe To Wall. Install Vents In Unpaved Areas Only.
- ⑲ Basket Type Strainer
- ⑳ 4" Pressure Relief Bermad Model 730-1-U w/ Valve Position Indicator Or Approved Equal Required When Pressure Differential Meets Or Exceeds 100 PSI. See Detail 2342-2.

* Engineer to note direction of flow and pressure setting on the plans.

DETAIL NO.
2342-1

**City of Scottsdale
Standard Details**

PRESSURE REDUCING VALVE

DETAIL NO.
2342-1

SEE DETAIL 2342-2 FOR GENERAL NOTES

REVISED 2/21/01

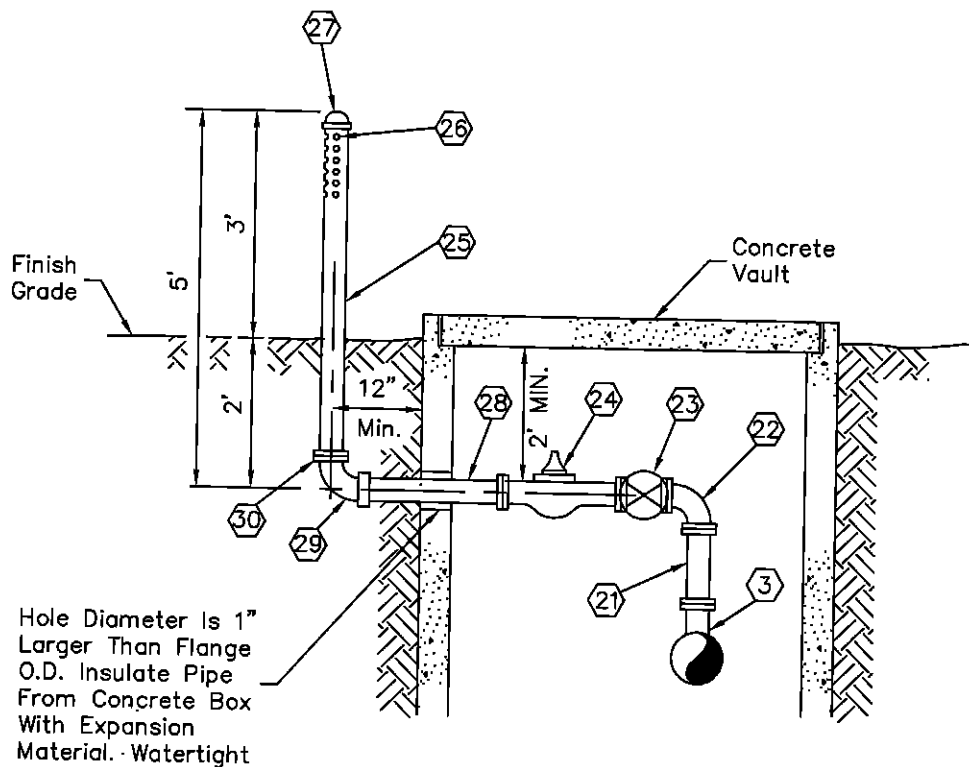

PRESSURE RELIEF OUTLET ASSEMBLY DETAIL

SEE NOTE 20 DETAIL 2342-1

NOTES

- 3 Fig x Fig Tee, See Detail 2342-1
- 21 4" Fig Connecting Piece
- 22 4" DIP Fig x Fig 90° Elbow, w/ Restrained Joints (Meg A Lug Or Approved Equal)
- 23 4" Fig NRS Resilient Wedge Gate Valve, Inside Epoxy Coated, Low Zinc Stem w/ Handwheel
- 24 4" Fig PRV Bermad Model 730-I-U Or Approved Equal, Epoxy Coated w/ Valve Position Indicator
- 25 4" SCH. 40 Steel Pipe (Painted Desert Beige)
- 26 6 Rows 2" O.C. Of 3-1"Ø Holes, 180° Spray Pattern
- 27 4" SCH 40 Steel Cap (Threaded)
- 28 4" Ductile Pipe Spool
- 29 4" DIP MJ x Fig 90° Elbow
- 30 Flanged Connection w/ Breakaway Bolts

GENERAL NOTES

1. All pipe and valves are to be rated per system pressure.
2. Pilot lines for all controls will be stainless steel tubing.
3. Stainless tubing bends will be uniform and made with a tubing bender.
4. Bypass line (small PRV) shall be 4" Min. D.I.P.
5. Airvents and relief outlet riser pipe shall not be located within 12 feet of an existing edge of pavement or within 2 feet of a barrier type curb or 2' back of sidewalk.

DETAIL NO.
2342-2

City of Scottsdale
Standard Details

PRESSURE REDUCING VALVE

DETAIL NO.
2342-2

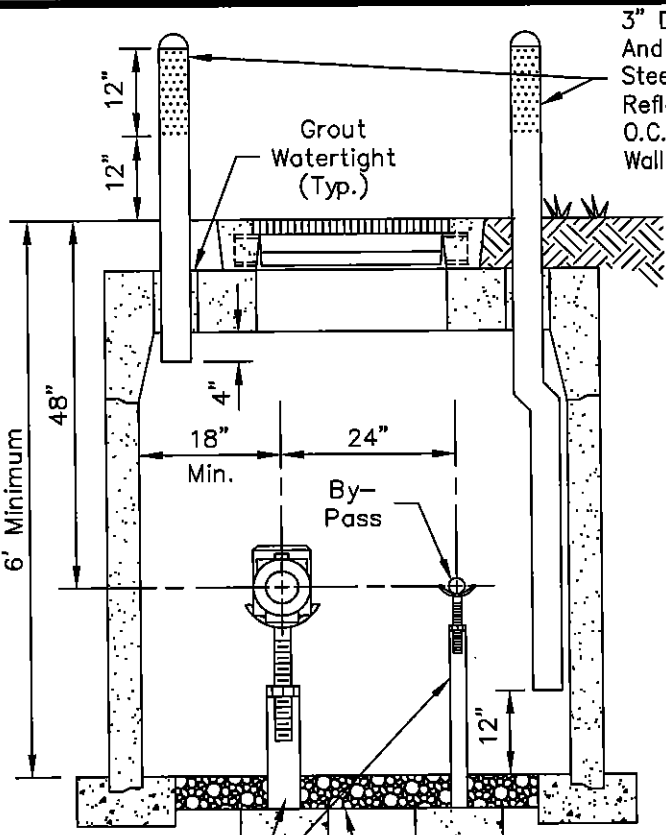

Adjustable Metal Pipe Support At Each Valve, And, Two Spaced Equally On Bypass Assembly

12"x12"x6" Concrete Base (Typ.)

4" Crushed Rock

SECTION A-A

3" Dia. Sch 40 Steel Vent Pipe W/ Cap And Bracket as Manufactured By Blue Dot Steel Or Approved Equal. Wrap Pipe With Reflective Tape Then Drill 1/4" ϕ Holes 1" O.C. In Top 12" Of Pipe. Strap Pipe To Wall. Install Vents In Unpaved Areas Only.

NOTE: Meter Vaults To Be Pre-Cast Concrete Unless Otherwise Approved By Water Operations. See MAG Std Detail 321 For Vault Construction.

VAULT DIMENSION TABLE			
MAIN SIZE	3"	4"	6"
(A)	8'-4"	10'-6"	12'-0"
(B)	4'-6"	5'-0"	5'-0"

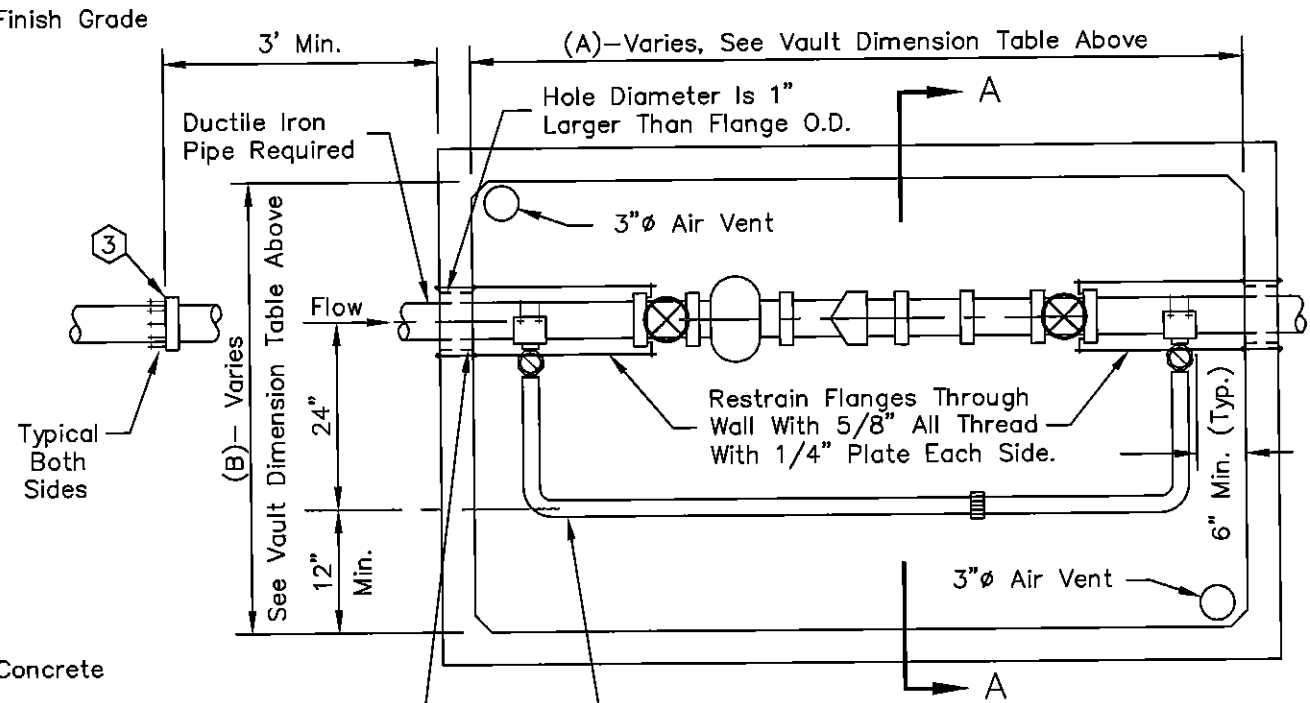

Insulate Water Main From Concrete Box With 1" Ramneck Or Other Expansion Material Approved By The Engineer. Grout Balance Of Opening Per MAG Specifications.

Except For 2" Copper Bypass All Fittings Will Be Flanged. Uniflange Not Acceptable Unless Approved By Water Operations. 2" Copper Bypass Will Be Joined With Silver Solder Except At 2" Corp Stop Which Will Be Pac Joint.

VAULT INSTALLATION

PLAN

SHEET 1 OF 2

DETAIL NO. **2345-1** City of Scottsdale Standard Details

3", 4", 6" WATER METER

DETAIL NO. **2345-1**

For Vault Construction
See MAG Std Det 321

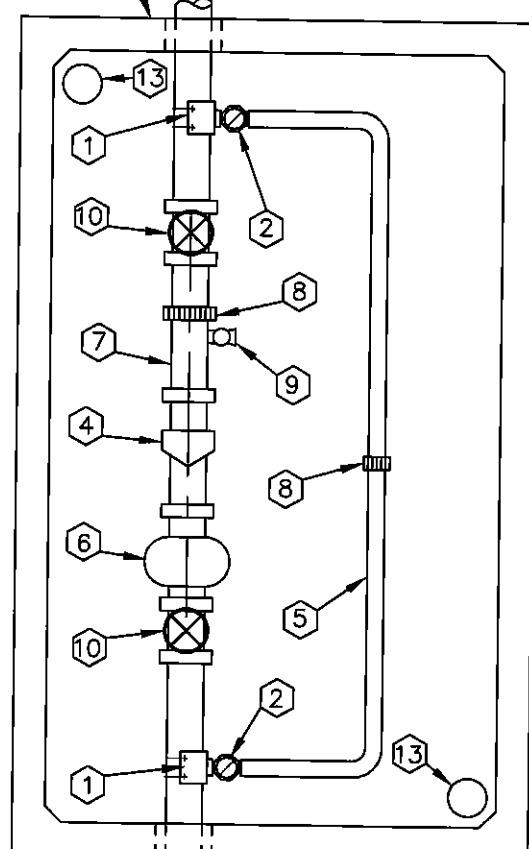
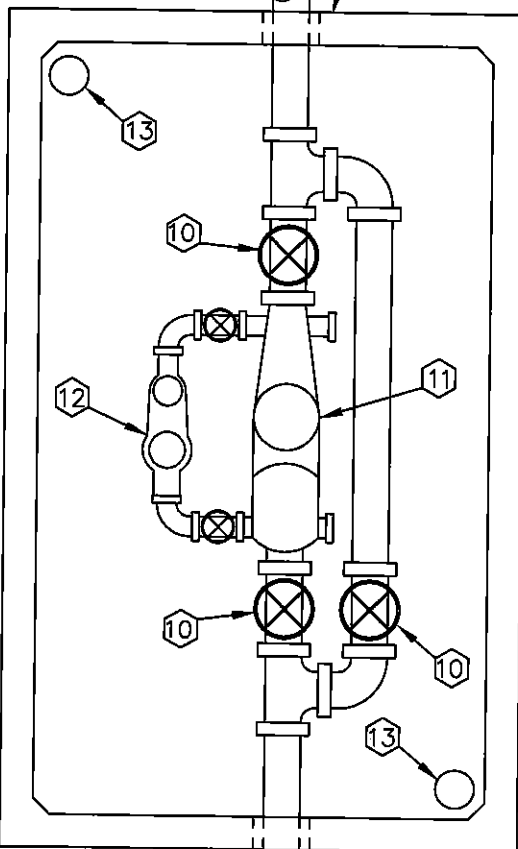

**COMBINATION DOMESTIC/
FIRE LINE METER**

COMPOUND/TURBINE METER

3' Min.

3' Min.

Typical Both
Sides

KEY NOTES

- ① Double Strap All Bronze Service Saddle, Or Flanged x Flanged Tee With Flanged X Flanged Valve For Sizes 3" Or Larger.
- ② Corp. Stop, 2"(Ball Type), Or R.W. Gate Valve With Non-Rising Stem Handwheel Operator For 3" Or Larger.
- ③ Adaptor, Flanged To Mech. Joint For A.C.P.
- ④ Turbine (High Flow) Or Compound Meter, See Note 4 Below.
- ⑤ 2" Ridged Type "K" Copper By-Pass Line, 3" Or Larger To Be Ductile Iron. Not Less Than One Pipe Size Smaller Than Meter In Note 4.
- ⑥ Strainer, Supplied with Meter.
- ⑦ Flanged Spool, (3 Pipe Diameters In Length, Min.).
- ⑧ Provide Victaulic Coupling Or Approved Equal For All Lines 3" Or Larger.
- ⑨ 2" Threaded Outlet And Ball Valve. Not Needed If Vertical Test Valve Is Provided On Meter.
- ⑩ Resilient Wedge Gate Valve, Flanged, With Hand Wheel, Open Left, With Non-Rising Stem.
- ⑪ Turbine (High Flow) Or Compound Meter, See Note 4 Below.
- ⑫ 2" Turbine Meter: Sensus "W-160" Or Hersey "MHR" Or Neptune Trident Turbine.
- ⑬ 3"ø Air Vent, See Sheet 1 Of 2.

NOTES

- 1. For Larger Meters Special Vault Design Is Required.
- 2. Use Of Remote Reading Device At Option Of Utility.
- 3. An Approved Backflow Prevention Assembly Shall Be Required Downstream Of The Water Meter. Contact Water Resources, Backflow Prevention For Specific Information.
- 4. Meter To Be Provided By City Upon Payment Of Fees.

DETAIL NO.
2345-2 City of Scottsdale
Standard Details

3, 4", 6" WATER METER

SHEET 2 OF 2

DETAIL NO.
2345-2

REVISED 2/21/01

GENERAL NOTES

1. Contractor to supply and install above ground piping and fittings to accommodate meter, strainer and 2 - 90° ells.
2. Contractor to remove piping and fittings after acceptance of new water main and complete connection as per MAG Standards.

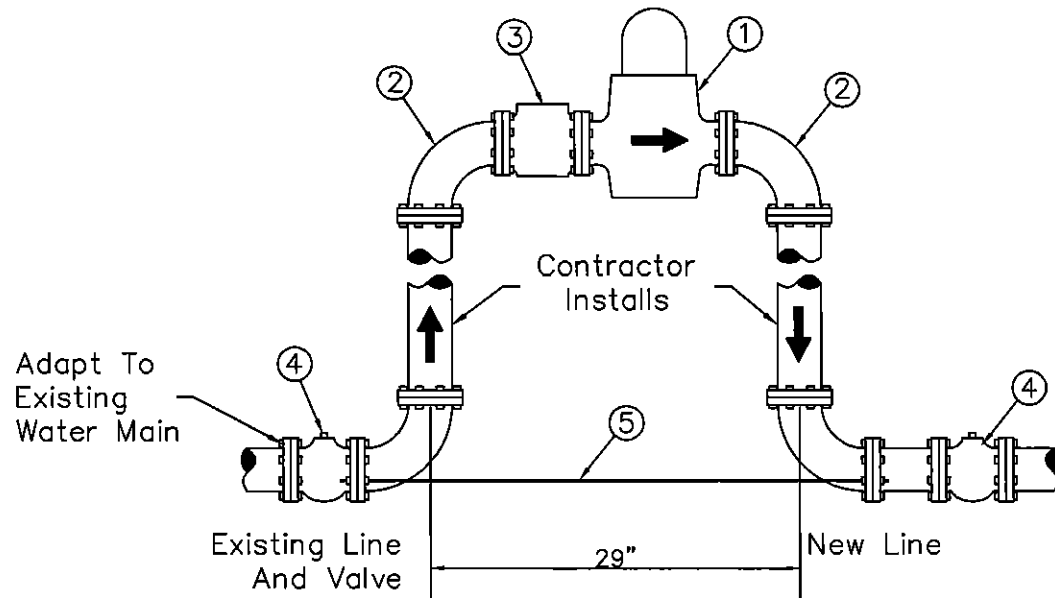

Adapt Size And Material
To New Non-Approved
Water Main

LIST OF MATERIALS

- ① 3", 4" & 6" Pressure regulating valve with meter and check feature - supplied by COS.
- ② 3", 4" & 6" Flanged ductile iron 90° ell - supplied by COS.
- ③ 3", 4" & 6" Strainer - supplied by COS.
- ④ Line valves shall be within a 20' maximum distance upstream and downstream of flow meter or as approved by COS, and shall remain in-place after removal of temporary meter.
- ⑤ 3/4"Ø zinc coated threaded rod.

DETAIL NO. **2346** **City of Scottsdale**
Standard Details

TEMPORARY CONSTRUCTION METER

DETAIL NO. **2346**

REVISED 2/21/01

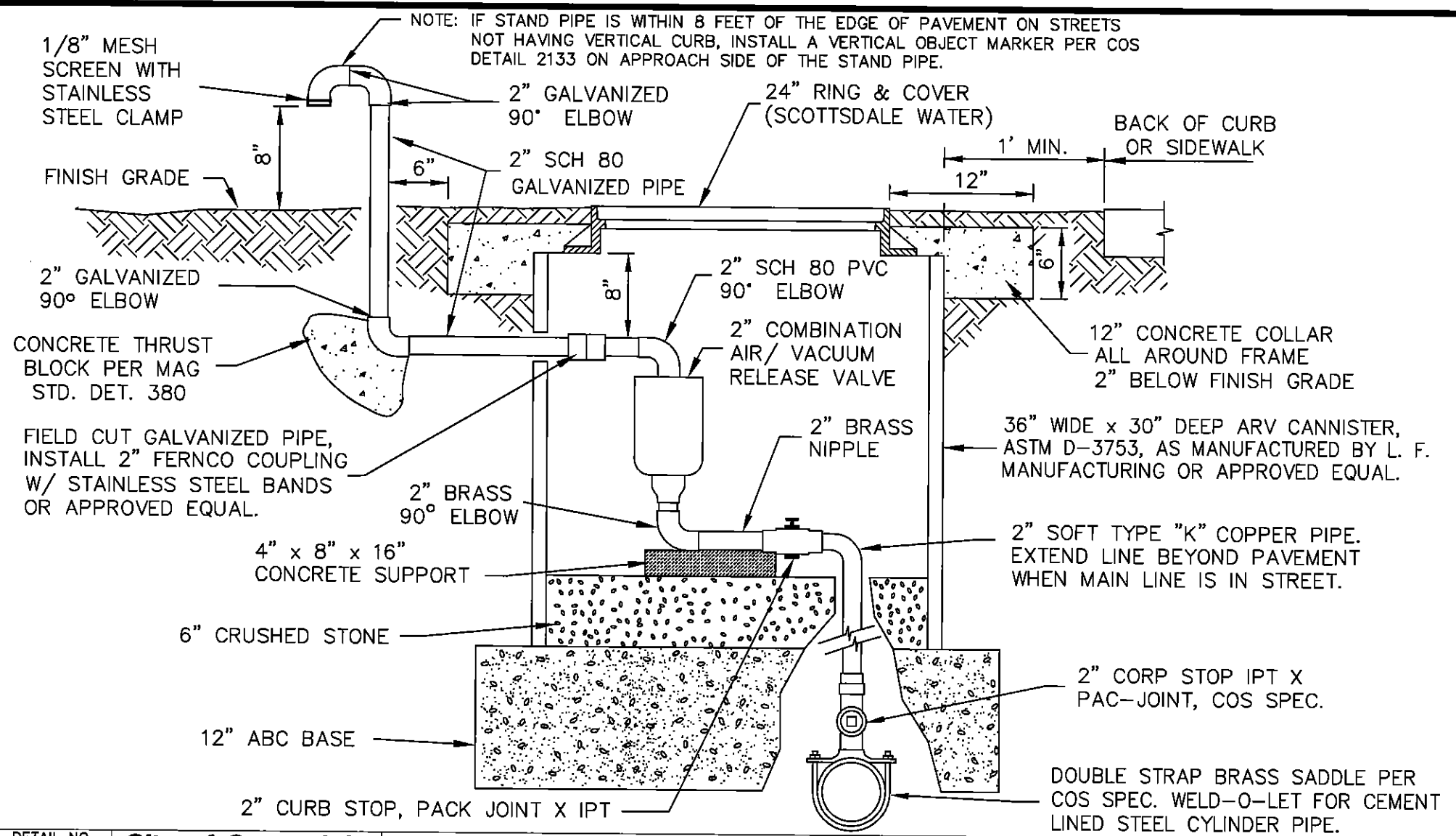

DETAIL NO. **2348** City of Scottsdale Standard Details

2" AIR/VACUUM RELEASE VALVE

DETAIL NO. **2348**

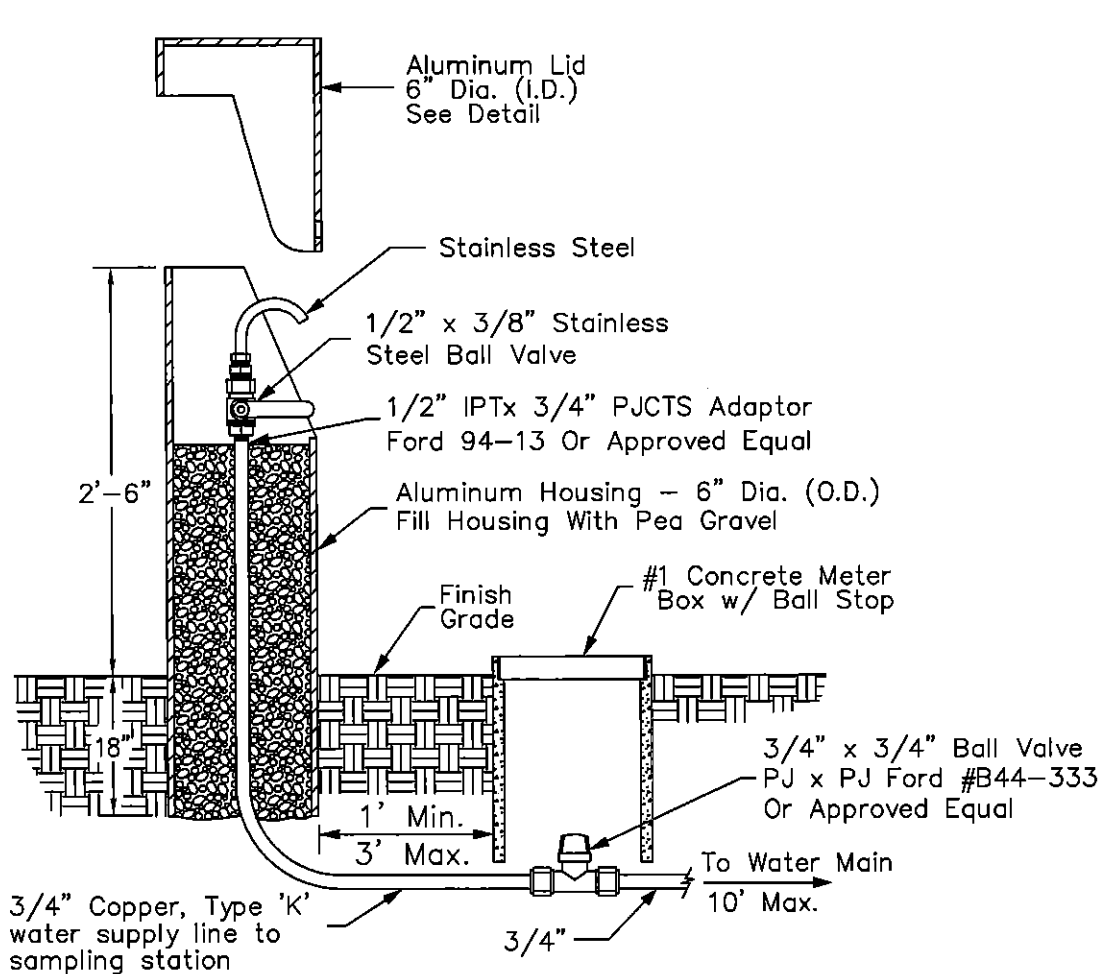

TYPICAL INSTALLATION

N.T.S.

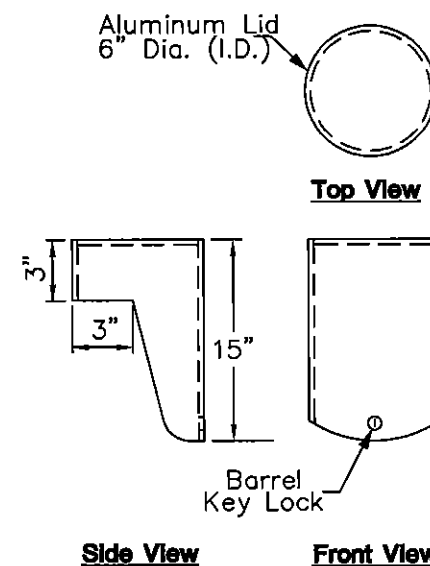

LID DETAILS

N.T.S.

NOTES:

1. Water Quality Sampling Station to be Koralean or approved equal.
2. Keys to locks shall be delivered to City of Scottsdale Water Quality Department upon acceptance.

DETAIL NO.
2349

**City of Scottsdale
Standard Details**

APPROVED BY:

WATER QUALITY SAMPLING STATION

DETAIL NO.
2349

REVISED 3/13/99

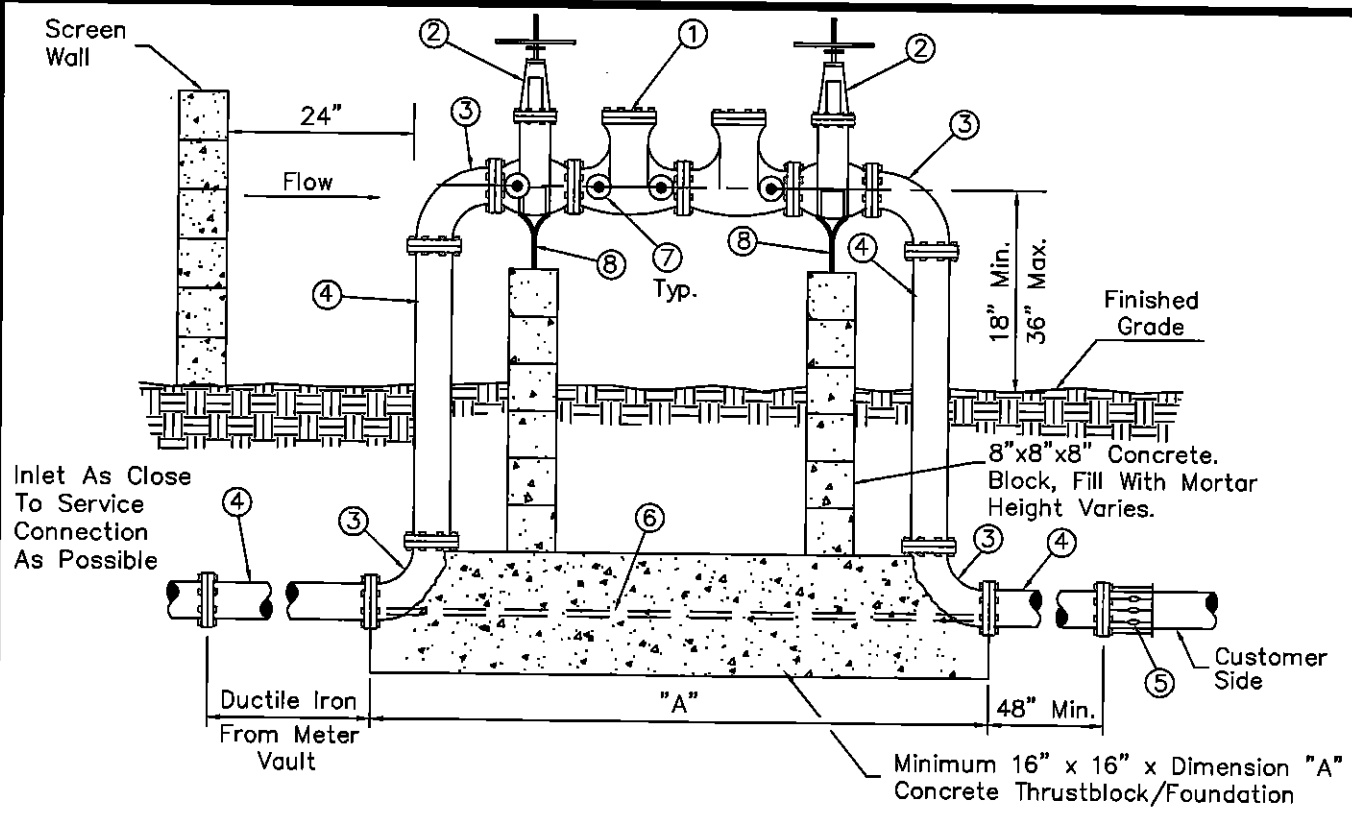

GENERAL NOTES

1. Contact the City Of Scottsdale Water And Wastewater Operations, Backflow Prevention, 312-5668, for latest list of approved backflow prevention assemblies or certified testers.
2. Backflow preventers must be tested by a certified tester before final approval is issued.
3. Backflow preventers shall be painted light tan or a color to match the building. Do not paint the name plate or any brass parts on the assembly.
4. For backflow preventers requiring guard posts see Detail 2356. Backflow preventers enclosed by screening shall maintain a 24 inch clearance around the assembly.
5. Finished grade underneath the backflow preventer shall be at 95% compaction.
6. Backflow preventers on fire lines may require tamper switches on the shut off valves. Contact City Of Scottsdale Plan Review, Fire Dept.
7. Call for underground inspection before backfilling trench.
8. Vertical installations of assemblies on fire sprinkler systems are allowed using assemblies approved for use in the vertical position on fire systems.

LIST OF MATERIALS

- | | |
|---|---|
| <ul style="list-style-type: none"> ① Approved double check valve backflow prevention assembly. ② Resilient seated gate valve.
O.S. & Y. (fire line connection)
N.R.S. (non fire line) ③ 90° ell. Flanged D.I.P. 3" thru 10", Mega Lug or approved equal may be used on underground joints. ④ Pipe spool. Flanged D.I.P. 3" thru 10", Mega Lug or approved equal may be used on underground joints. ⑤ Flanged adapter (when required) | <ul style="list-style-type: none"> ⑥ 3/4" zinc coated threaded rod, (5/8" rod on 3" to 4" sizes), bolt to flanges as shown, typical both sides. ⑦ Test cocks with brass plugs or adaptors with caps installed. (4 required) ⑧ Adjustable metal pipe supports and concrete block supports with 1" adjusting rod and nut on assemblies 4" and larger. Install above grade. |
|---|---|

DETAIL NO. 2351	City of Scottsdale Standard Details	APPROVED BY: _____	DOUBLE CHECK VALVE BACKFLOW PREVENTION ASSEMBLY FOR ASSEMBLIES 3 INCHES THRU 10 INCHES	DETAIL NO. 2351
---------------------------	---	--------------------	---	---------------------------

REVISED 3/15/93

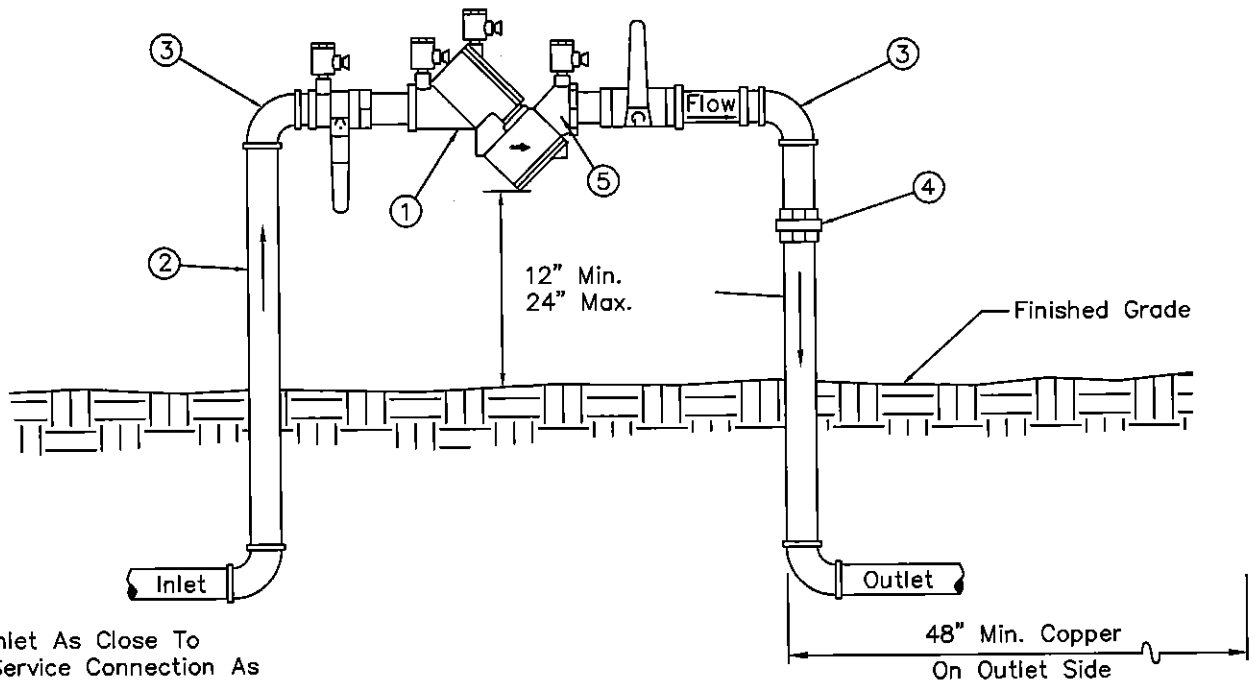

Inlet As Close To Service Connection As Possible (Immediately After Water Meter).
Copper On Inlet Side.

LIST OF MATERIALS

- ① Approved double check valve backflow prevention assembly, ball valves included.
- ② Pipe spool, type "L" hard copper, 3/4" thru 2 1/2".
- ③ 90° ell, copper, 3/4" thru 2 1/2".
- ④ Pipe union, brass or copper.
- ⑤ Test cocks with brass plugs or adaptors with caps installed. (4 required)

GENERAL NOTES

- 1. Contact the City Of Scottsdale Water And Wastewater Operations, Backflow Prevention, 312-5668, for latest list of approved backflow prevention assemblies or certified testers.
- 2. Backflow preventers must be tested by a certified tester before final approval is issued.
- 3. Copper fittings shall be connected with lead free solder joints.
- 4. Finished grade underneath the backflow preventer shall be at 95% compaction.
- 5. All nipples to be copper or brass.
- 6. Piping under the City right of way must be type "K" copper.
- 7. Call for underground inspection before backfilling trench.
- 8. Vertical installations of assemblies on fire sprinkler systems are allowed using assemblies approved for use in the vertical position on fire systems.

DETAIL NO.
2352 City of Scottsdale
Standard Details

APPROVED BY:

**DOUBLE CHECK VALVE BACKFLOW PREVENTION ASSEMBLY
FOR ASSEMBLIES 3/4 INCH THRU 2 1/2 INCHES**

DETAIL NO.
2352

REVISED 3/15/92

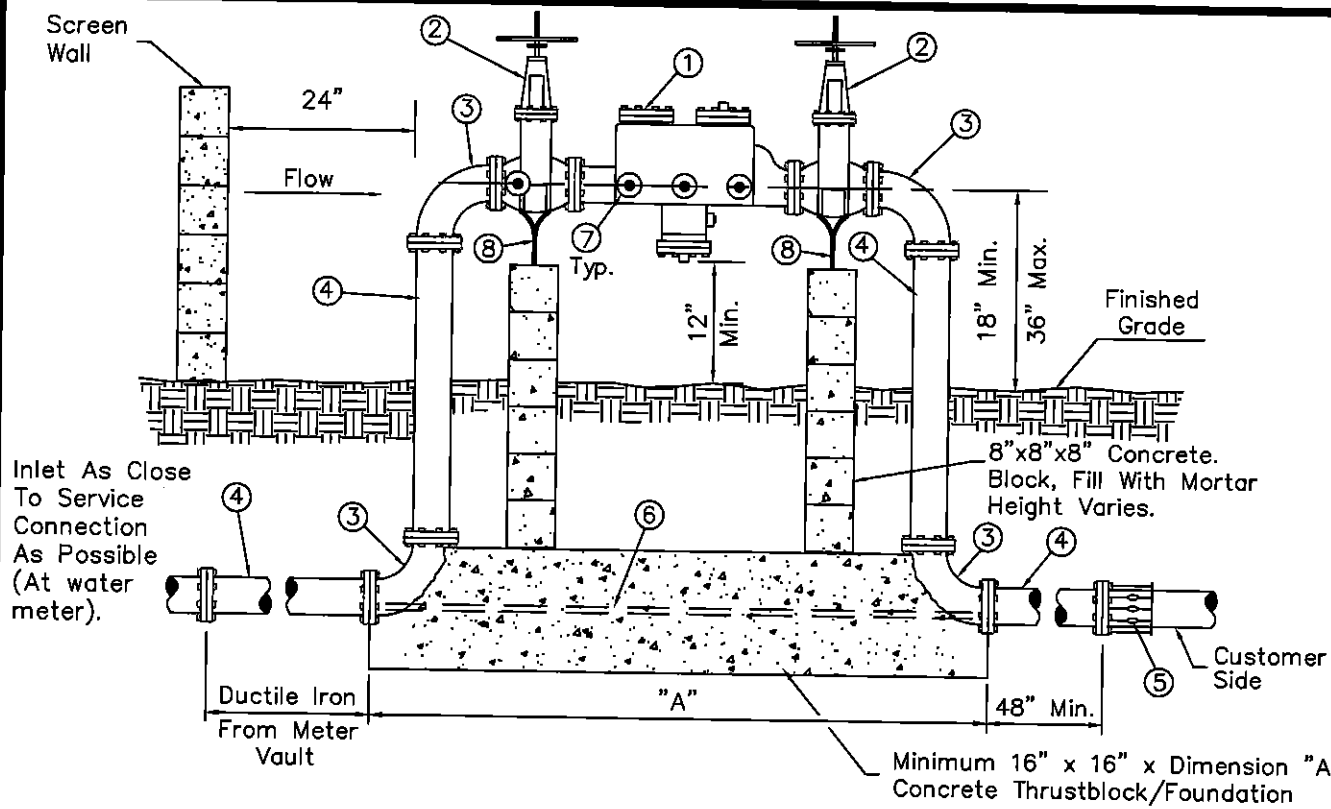

GENERAL NOTES

1. Contact the City Of Scottsdale Water And Wastewater Operations, Backflow Prevention, 312-5668, for latest list of approved backflow prevention assemblies or certified testers.
2. Backflow preventers must be tested by a certified tester before final approval is issued.
3. Backflow preventers shall be painted light tan or a color to match the building. Do not paint the name plate or any brass parts on the assembly.
4. For backflow preventers requiring guard posts see Detail 2356. Backflow preventers enclosed by screening shall maintain a 24 inch clearance around the assembly.
5. Finished grade underneath the backflow preventer shall be at 95% compaction.
6. Backflow preventers on fire lines may require tamper switches on the shut off valves. Contact City Of Scottsdale Plan Review, Fire Dept.
7. Call for underground inspection before backfilling trench.

LIST OF MATERIALS

- | | |
|--|---|
| <ul style="list-style-type: none"> ① Approved reduced pressure principle backflow prevention assembly. ② Resilient seated gate valve. O.S. & Y. (fire line connection). N.R.S. (non fire line) ③ 90° ell. Flanged D.I.P. 3" thru 10", Mega Lug or approved equal may be used on underground joints. ④ Pipe spool. Flanged D.I.P. 3" thru 10", Mega Lug or approved equal may be used on underground joints. ⑤ Flanged adapter (when required) | <ul style="list-style-type: none"> ⑥ 3/4" zinc coated threaded rod, (5/8" rod on 3" to 4" sizes), bolt to flanges as shown, typical both sides. ⑦ Test cocks with brass plugs or adaptors with caps installed. (4 required) ⑧ Adjustable metal pipe supports and concrete block supports with 1" adjusting rod and nut on assemblies 4" and larger. Install above grade. |
|--|---|

DETAIL NO. 2353	City of Scottsdale Standard Details	APPROVED BY: _____	REDUCED PRESSURE PRINCIPLE BACKFLOW PREVENTION ASSEMBLY FOR ASSEMBLIES 3 INCHES THRU 10 INCHES	DETAIL NO. 2353
---------------------------	---	--------------------	---	---------------------------

REVISED 3/15/99

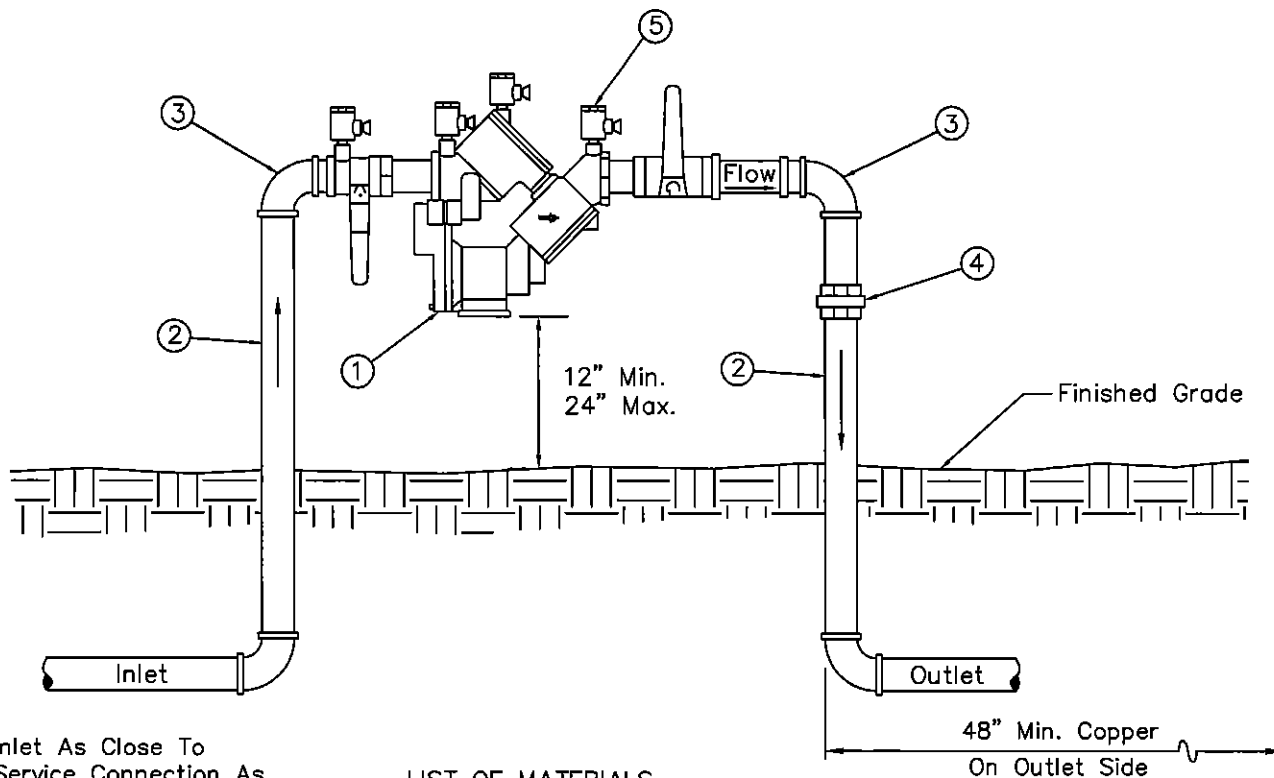

Inlet As Close To Service Connection As Possible (Immediately After Water Meter).
Copper On Inlet Side.

LIST OF MATERIALS

- ① Approved reduced pressure principle backflow prevention assembly, ball valves included.
- ② Pipe spool, type "L" hard copper, 3/4" thru 2 1/2".
- ③ 90° ell, copper, 3/4" thru 2 1/2".
- ④ Pipe union, brass or copper.
- ⑤ Test cocks with brass plugs or adaptors with caps installed. (4 Required)

GENERAL NOTES

1. Contact the City Of Scottsdale Water And Wastewater Operations, Backflow Prevention 312-5668, for latest list of approved backflow prevention assemblies or certified testers.
2. Backflow preventers must be tested by a certified tester before final approval is issued.
3. Copper fittings shall be connected with lead free solder joints.
4. Finished grade underneath the backflow preventer shall be at 95% compaction.
5. All nipples to be copper or brass.
6. Piping under the City right of way must be type "K" copper.
7. Call for underground inspection before backfilling trench.

DETAIL NO.
2354

City of Scottsdale
Standard Details

APPROVED BY:

REDUCED PRESSURE PRINCIPLE BACKFLOW PREVENTION ASSEMBLY FOR ASSEMBLIES 3/4 INCH THRU 2 1/2 INCHES

DETAIL NO.
2354

REVISED 3/15/99

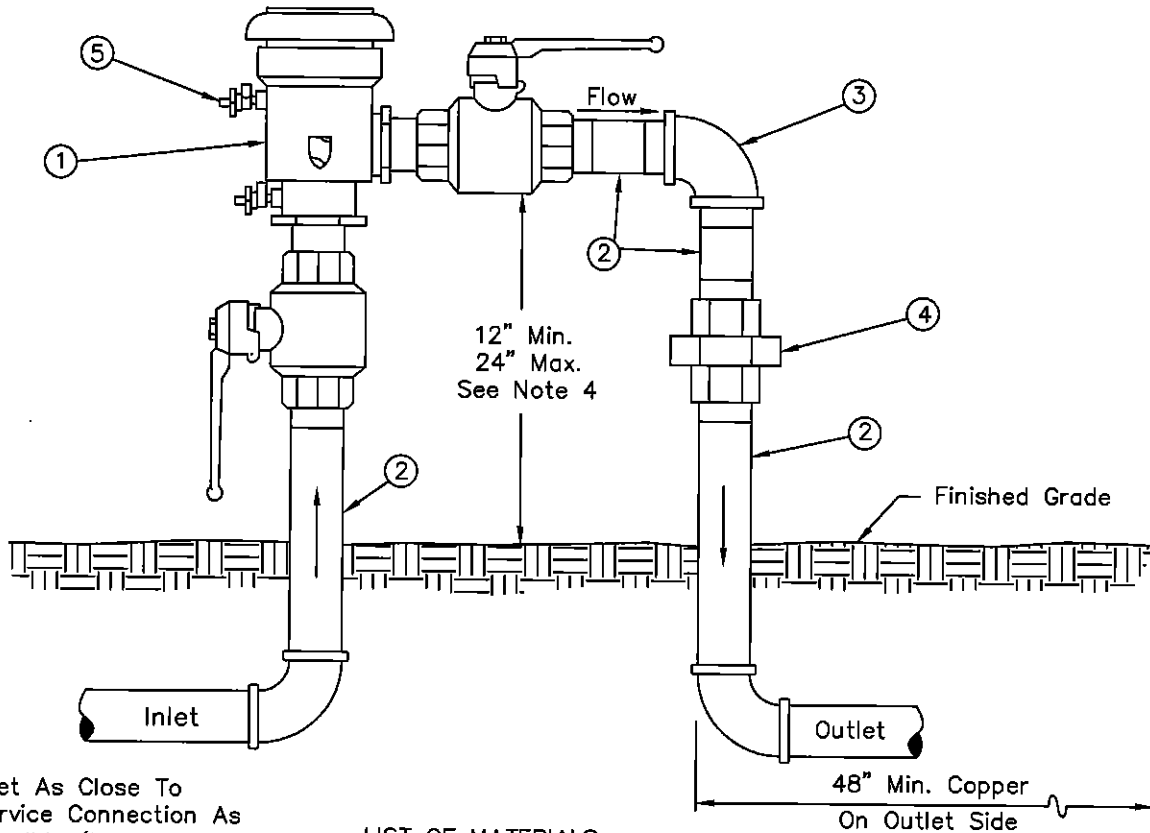

Inlet As Close To Service Connection As Possible (Immediately After Water Meter).
Copper On Inlet Side.

LIST OF MATERIALS

- ① Approved pressure vacuum breaker assembly, ball valves included.
- ② Pipe spool, type "L" hard copper, 1/2" thru 2".
- ③ 90° ell, copper, 1/2" thru 2".
- ④ Pipe union, brass or copper.
- ⑤ Test cocks with brass plugs or adaptors with caps installed. (2 required)

GENERAL NOTES

- 1. Contact the City Of Scottsdale Water And Wastewater Operations, Backflow Prevention, 312-5668, for latest list of approved backflow prevention assemblies or certified testers.
- 2. Backflow preventers must be tested by a certified tester before final approval is issued.
- 3. Pressure vacuum breakers must be installed at least 12" above all downstream piping.
- 4. If this distance exceeds 24 inches, a reduced pressure principle backflow prevention assembly must be utilized. See Detail 2354.
- 5. Copper fittings shall be connected with lead free solder joints.
- 6. Finished grade underneath the backflow preventer shall be at 95% compaction.
- 7. All nipples to be copper or brass.
- 8. Piping under the City right of way must be type "K" copper.
- 9. Call for underground inspection before backfilling trench.

DETAIL NO. 2355	City of Scottsdale Standard Details	APPROVED BY: <hr style="border: 0; border-top: 1px solid black; width: 100%;"/>	PRESSURE VACUUM BREAKER ASSEMBLY FOR ASSEMBLIES 1/2 INCH THRU 2 INCHES	DETAIL NO. 2355
---------------------------	---	--	---	---------------------------

REVISED 2/05/96

NOTE:
Guard posts are required at these locations if backflow prevention assembly is in an open area. (Not next to a building wall or fence.)

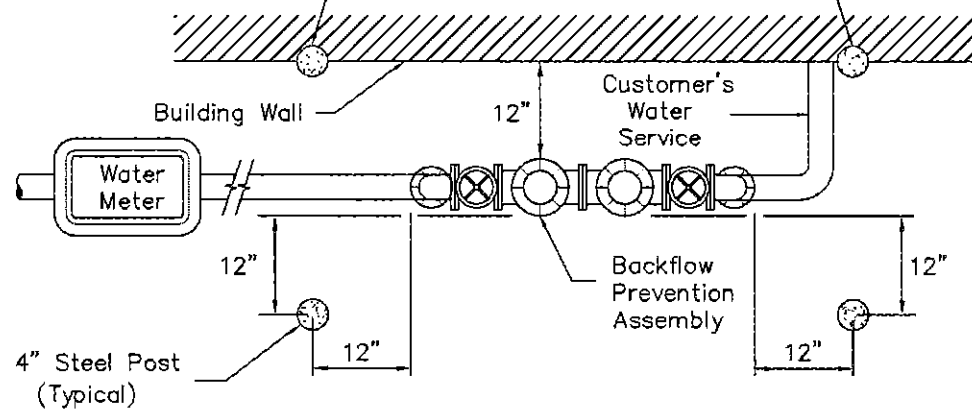

PLAN VIEW

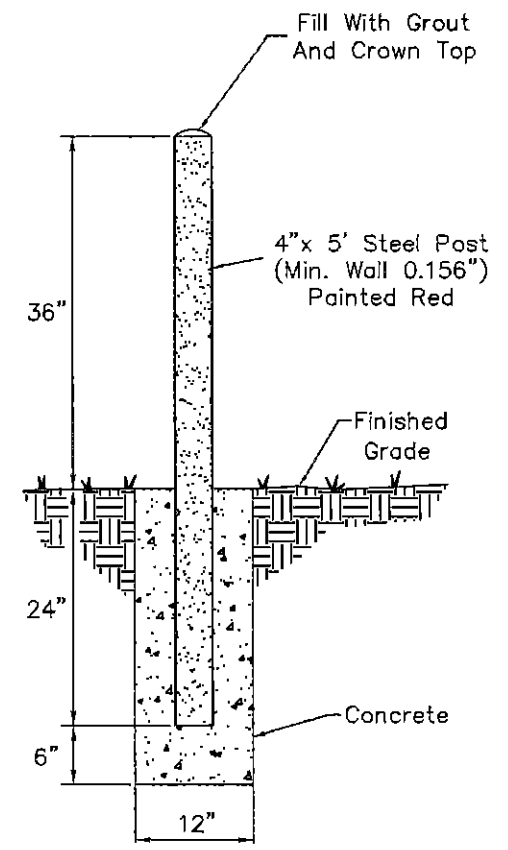

GUARD POST SECTION

DETAIL NO.
2356

City of Scottsdale
Standard Details

APPROVED BY:

GUARD POSTS FOR BACKFLOW PREVENTION ASSEMBLIES

DETAIL NO.
2356

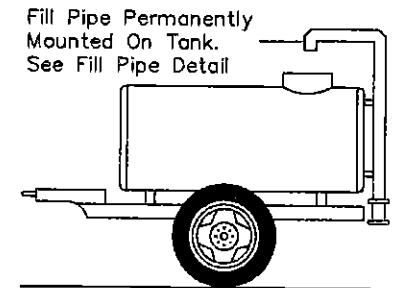
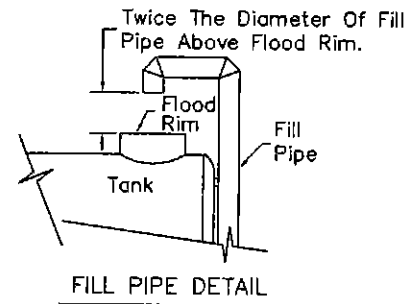
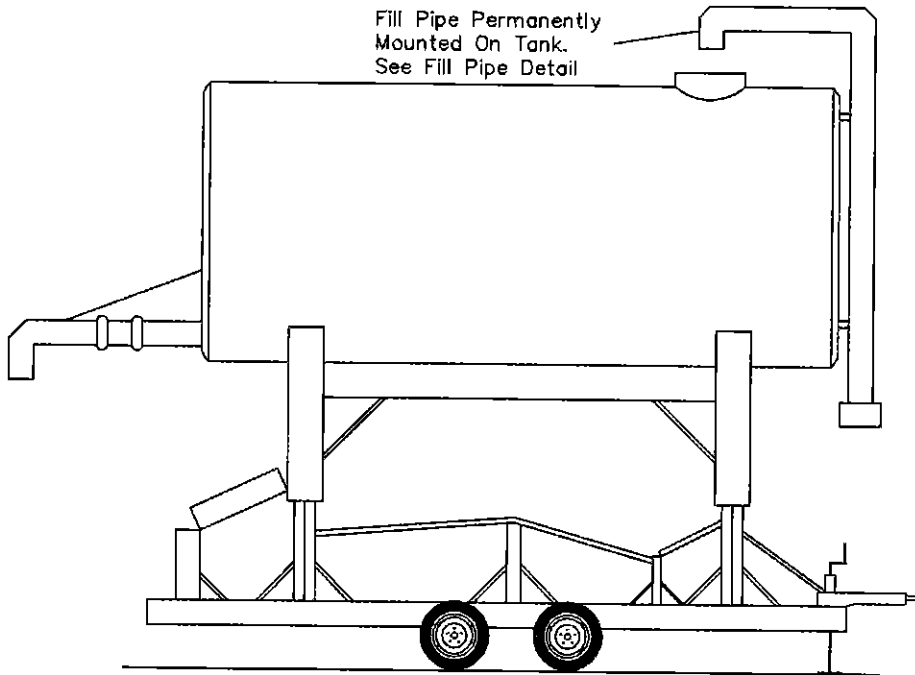
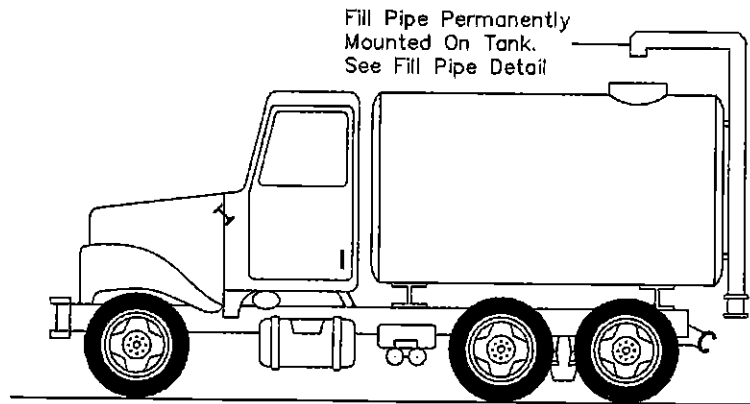
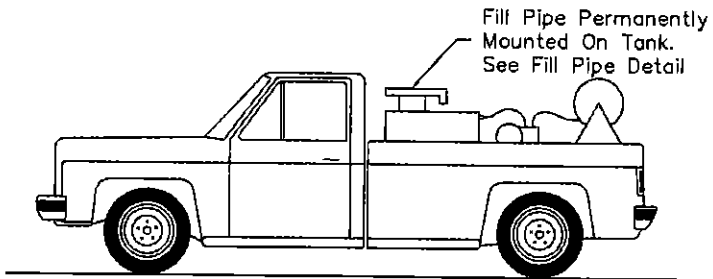

DETAIL NO.
2357

City of Scottsdale
Standard Details

APPROVED BY: _____

**FILL PIPE DETAILS FOR PORTABLE TANKS WITH
AIR GAP SEPARATION**

DETAIL NO.
2357

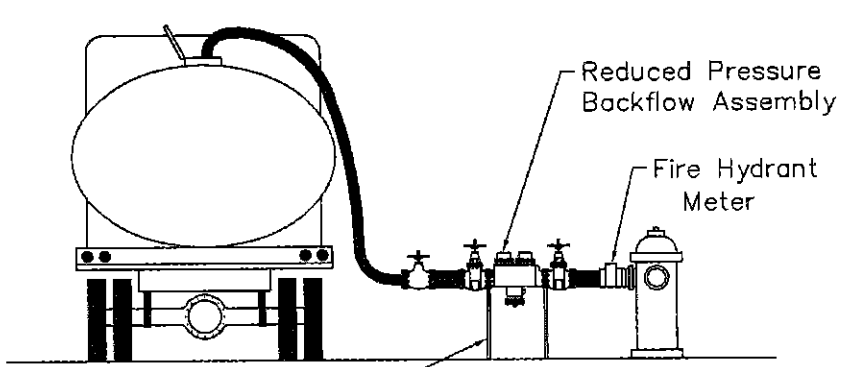

Supports Required

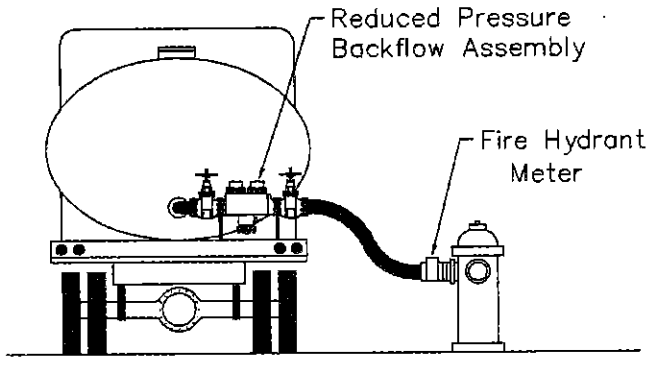

TANK TRUCKS

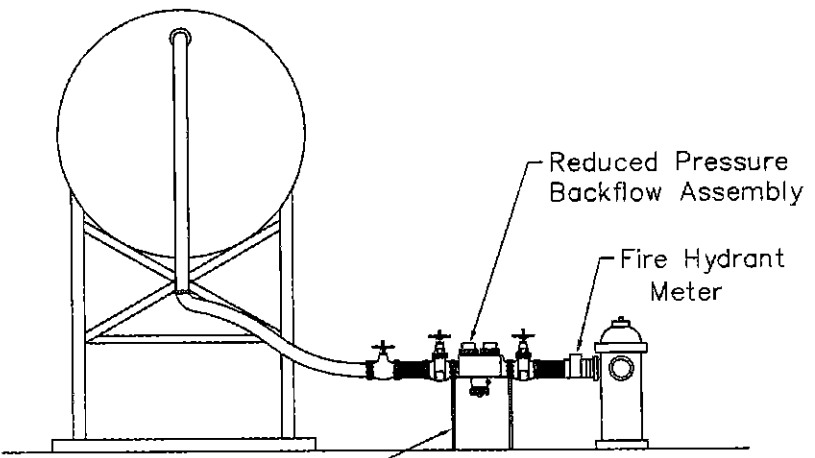

Supports Required

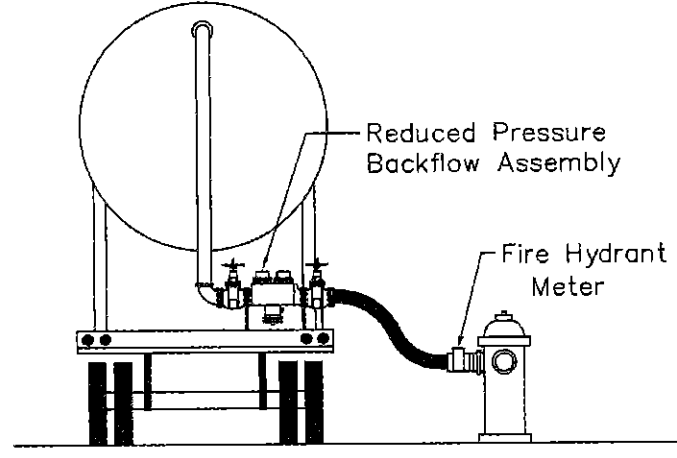

ELEVATED TANKS

DETAIL NO.
2358

**City of Scottsdale
Standard Details**

APPROVED BY:

**BACKFLOW PREVENTION METHOD FOR PORTABLE TANKS
WITH NO AIR GAP SEPARATION**

DETAIL NO.
2358

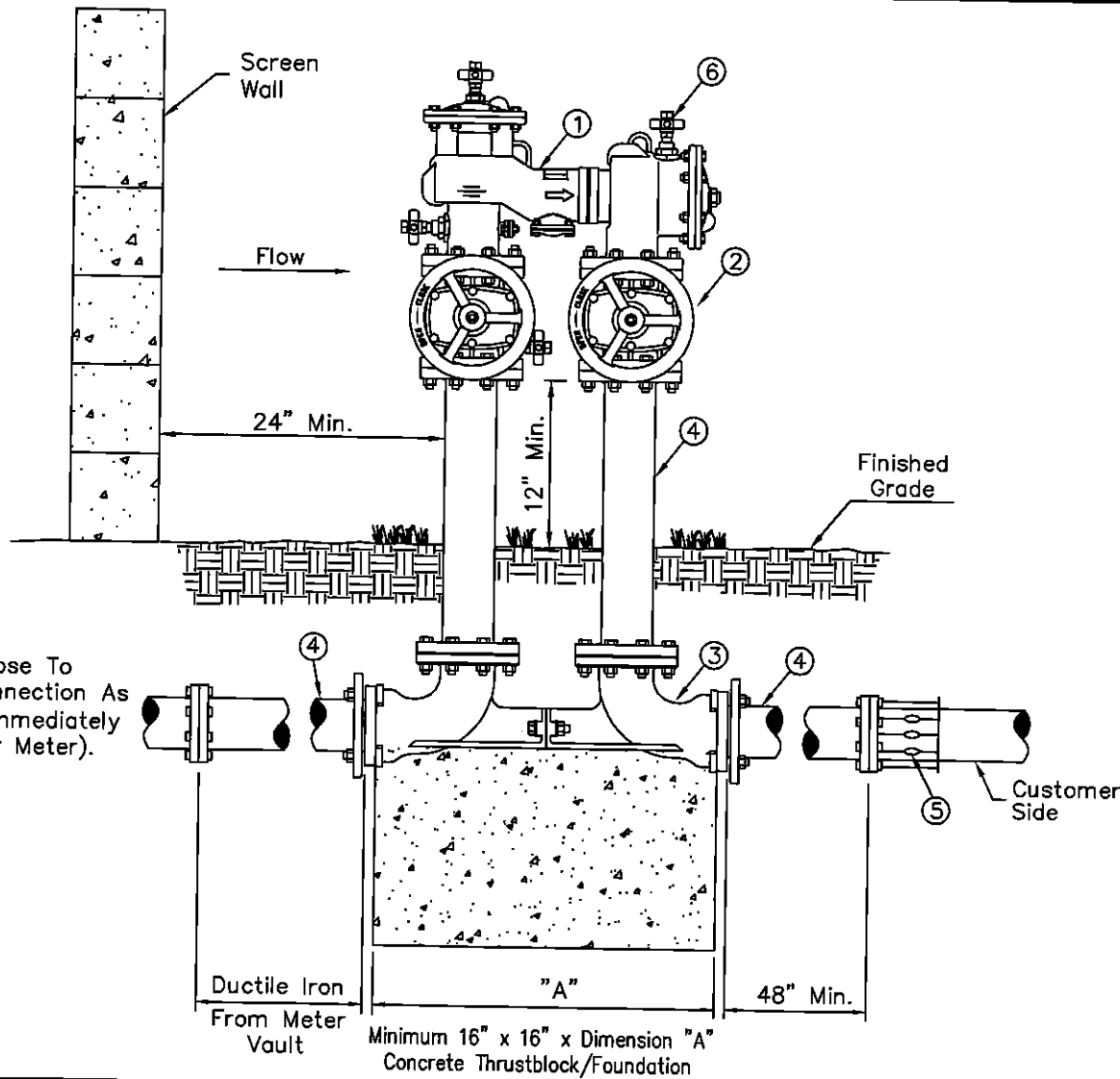

Inlet As Close To Service Connection As Possible (Immediately After Water Meter).

GENERAL NOTES

1. Contact the City Of Scottsdale Water And Wastewater Operations, Backflow Prevention, 312-5668, for latest list of approved backflow prevention assemblies or certified testers.
2. Backflow preventers must be tested by a certified tester before final approval is issued.
3. Backflow preventers shall be painted light tan or a color to match the building. Do not paint the name plate or any brass parts on the assembly.
4. For backflow preventers requiring guard posts see Detail 2356. Backflow preventers enclosed by screening shall maintain a 24 inch clearance around the assembly.
5. Finished grade underneath the backflow preventer shall be at 95% compaction.
6. Backflow preventers on fire lines may require tamper switches on the shut off valves. Contact City Of Scottsdale Plan Review, Fire Dept.
7. Call for underground inspection before backfilling trench.

LIST OF MATERIALS

- ① Approved "N" shape double check valve backflow prevention assembly.
- ② Resilient seated gate valve.
O.S. & Y. (fire line connection)
N.R.S. (non fire line)
- ③ Valve setters, fusion epoxy coated ductile iron, plated nuts and bolts. (2 required)
- ④ Pipe spool. Flanged D.I.P. 3" thru 10", Mega Lug or approved equal may be used on underground joints.
- ⑤ Flanged adapter (when required)
- ⑥ Test cocks with brass plugs or adaptors with caps installed. (4 required)

DETAIL NO.
2359

**City of Scottsdale
Standard Details**

APPROVED BY:

**'N' SHAPED DOUBLE CHECK VALVE BACKFLOW PREVENTION
ASSEMBLY FOR ASSEMBLIES 3 INCHES THRU 10 INCHES**

DETAIL NO.
2359

REVISED 5/15/53

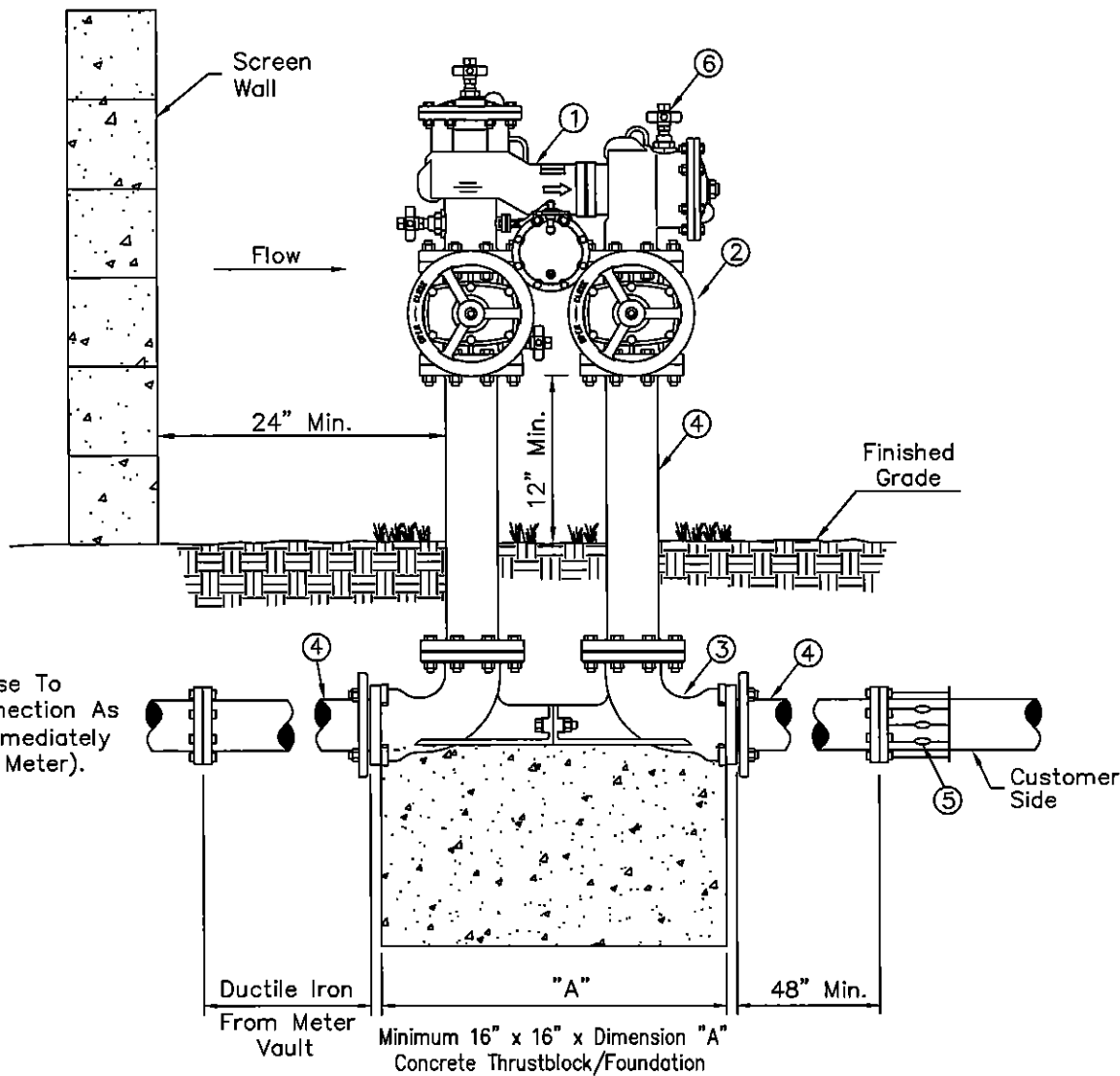

Inlet As Close To Service Connection As Possible (Immediately After Water Meter).

GENERAL NOTES

1. Contact the City Of Scottsdale Water And Wastewater Operations, Backflow Prevention, 312-5668, for latest list of approved backflow prevention assemblies or certified testers.
2. Backflow preventers must be tested by a certified tester before final approval is issued.
3. Backflow preventers shall be painted light tan or a color to match the building. Do not paint the name plate or any brass parts on the assembly.
4. For backflow preventers requiring guard posts see Detail 2356. Backflow preventers enclosed by screening shall maintain a 24 inch clearance around the assembly.
5. Finished grade underneath the backflow preventer shall be at 95% compaction.
6. Backflow preventers on fire lines may require tamper switches on the shut off valves. Contact City Of Scottsdale Plan Review, Fire Dept.
7. Call for underground inspection before backfilling trench.

LIST OF MATERIALS

- ① Approved "N" shape reduced pressure principle backflow prevention assembly.
- ② Resilient seated gate valve. O.S. & Y. (fire line connection) N.R.S. (non fire line)
- ③ Valve setters, fusion epoxy coated ductile iron, plated nuts and bolts. (2 required)
- ④ Pipe spool. Flanged D.I.P. 3" thru 10", Mega Lug or approved equal may be used on underground joints.
- ⑤ Flanged adapter (when required)
- ⑥ Test cocks with brass plugs or adaptors with caps installed. (4 required)

DETAIL NO.
2360

**City of Scottsdale
Standard Details**

APPROVED BY: _____

**"N" SHAPED REDUCED PRESSURE PRINCIPLE BACKFLOW PREVENTION
ASSEMBLY FOR ASSEMBLIES 3 INCHES THRU 10 INCHES**

DETAIL NO.
2360

NOTES

1. All joints in hydrant run-out to be restrained joints.
2. See MAG Std. Detail 391-C for valve box installation.
3. For water valve blocking see MAG Std. Detail 301.
4. For additional information see MAG Std. Detail 360.

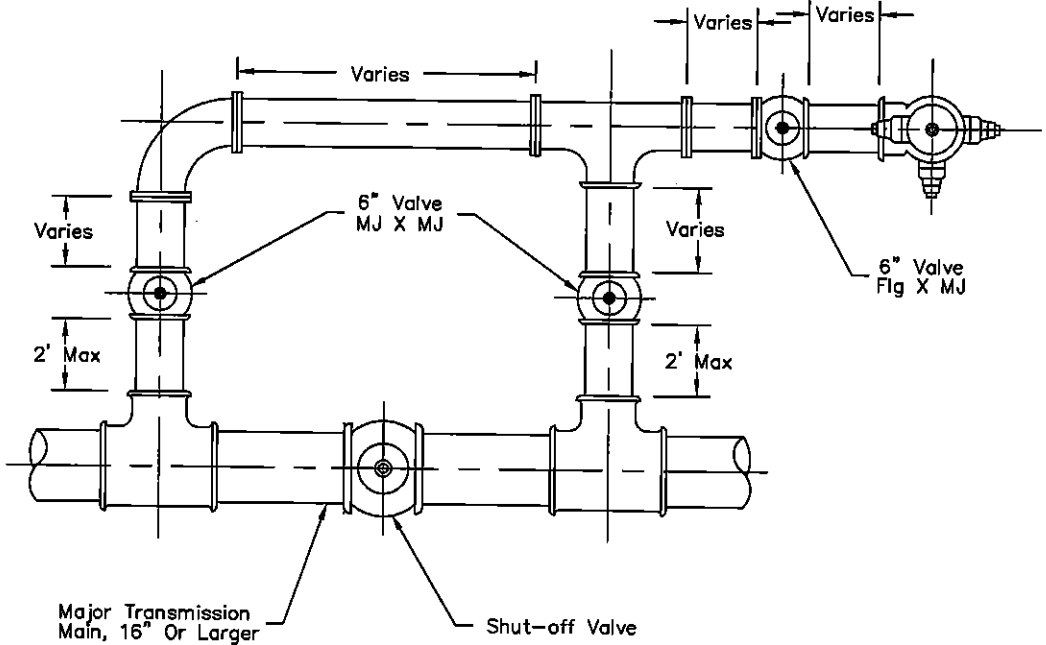
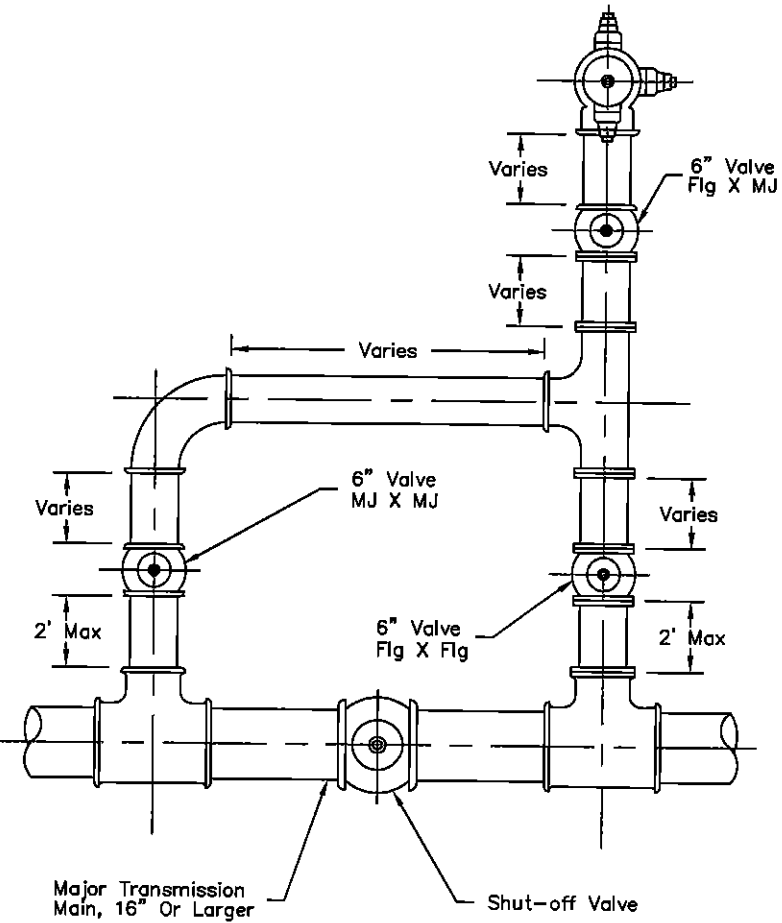

DETAIL NO. **2361** City of Scottsdale
Standard Details

APPROVED BY: _____

FIRE HYDRANT BYPASS ASSEMBLY

DETAIL NO. **2361**

REVISED 4/1/00

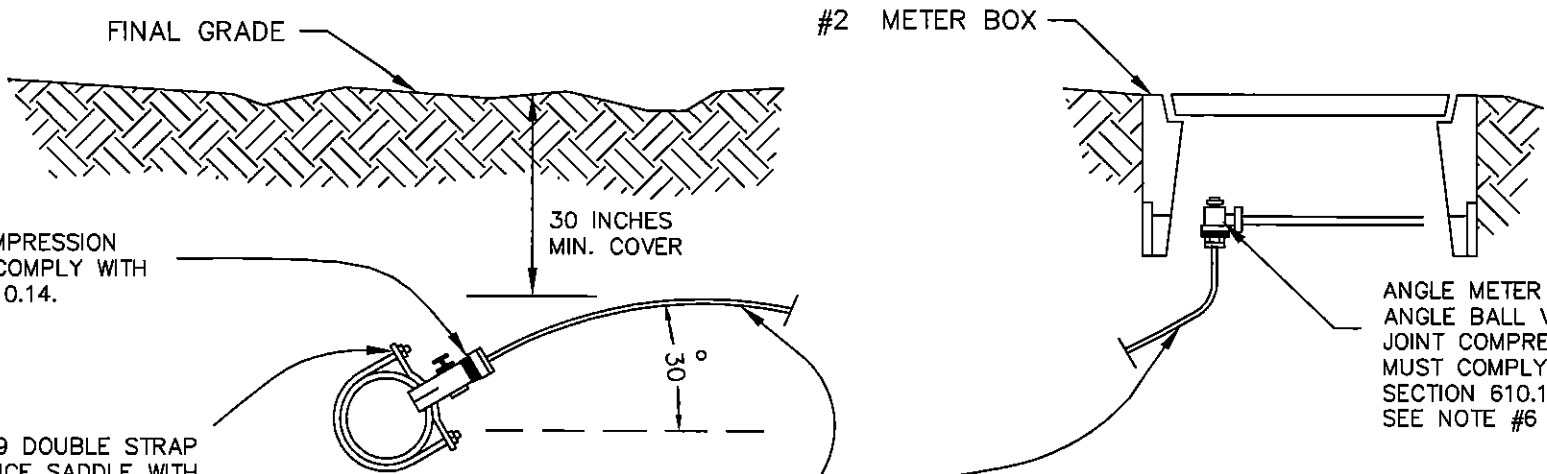

CORP. STOP:
 PACK JOINT COMPRESSION
 FITTINGS MUST COMPLY WITH
 MAG SECTION 610.14.

JONES #J-979 DOUBLE STRAP
 BRONZE SERVICE SADDLE WITH
 I.P. THREAD OR APPROVED
 EQUAL FOR ALL DUCTILE IRON,
 A, C, AND CAST IRON PIPE. FULL
 CIRCLE BRONZE SERVICE SADDLE
 FOR ALL PVC PIPE.

SERVICE LINE:
 TYPE K SOFT COPPER PER MAG SPEC.
 754.1 FOR 1 1/2" AND 2" SERVICES.

ANGLE METER STOP OR
 ANGLE BALL VALVE PACK
 JOINT COMPRESSION FITTINGS
 MUST COMPLY WITH MAG
 SECTION 610.14.
 SEE NOTE #6

- NOTE:
1. All taps must be made using a service saddle.
 2. All service line sizes shall have the pack joint compression fittings for corp. stops and meter stops.
 3. Where a contractor is installing new water lines, he shall also install the water service connection. The installation shall include the service saddle, corp. stop, service pipe, appurtenant fittings, meter stop, concrete meter box and box cover, per M.A.G. Specifications.
 4. Copper service lines in the 1 1/2", and 2" sizes that cross streets will be one continuous piece. Only with the express written consent of Water & Wastewater Operations will joints be permitted under a road. When this occurs, pack joint fittings will be required; no soldered joints will be permitted.
 5. When all or part of a development is to be served by existing City of Scottsdale water mains, only authorized City of Scottsdale Water and Wastewater Operations personnel shall install the fire service connection.
 6. Fire Department Identification Tag is required. Water resistant tag shall be affixed to valve in meter box and shall state: "DO NOT CLOSE! Fire Sprinkler Supply Line".

DETAIL NO. 2362	City of Scottsdale Standard Details	1 1/2" - 2" FIRE LINE CONNECTION	DETAIL NO. 2362
---------------------------	--	---	---------------------------

REVISED 6/15/91

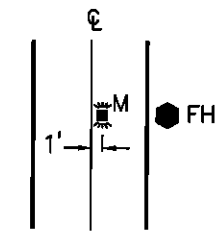

Midblock Local

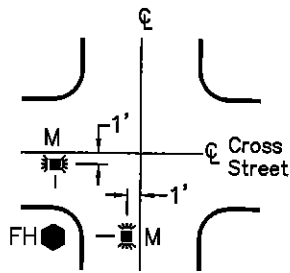

Local Cross Intersection

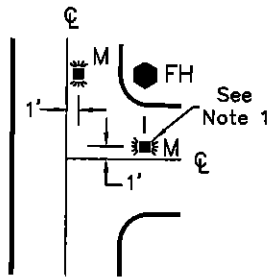

Local T Intersection

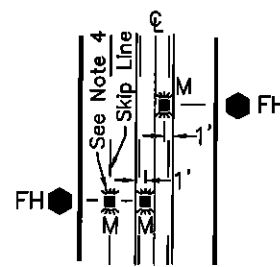

Midblock WITH CENTER LANE OR SKIP LINES

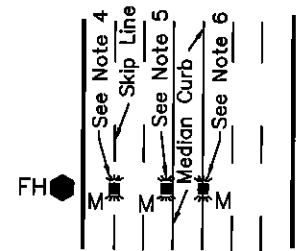

Midblock WITH RAISED MEDIAN

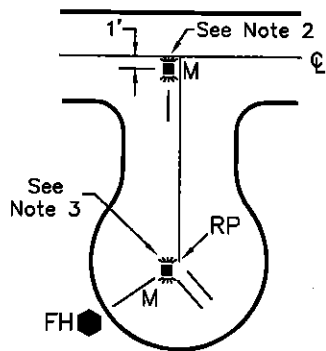

Cul-De-Sac Street

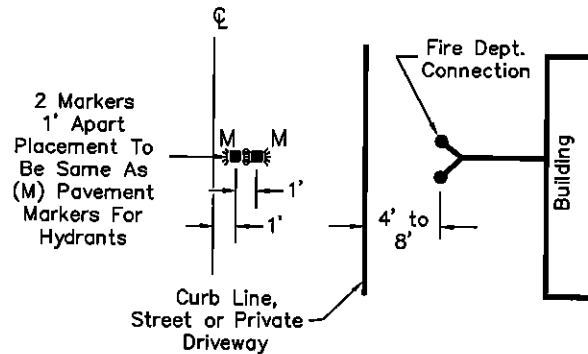

Fire Dept. Connection

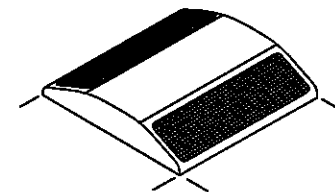

(M) Pavement Marker (2-WAY REFLECTIVE BLUE)

NOTES:

1. Not Required on Dead End Streets Without Hydrants
2. Place on Hydrant Side of Centerline.
3. Not Required When Cul-De-Sac is Less Than 250'.
4. To Be Placed in Line With Skip Line.
5. Place on Gutter or Adjacent To Curb.
6. Place on Top of Curb. (This Location Optional)
7. Pavement Markers Shall Not Be Placed Within One Foot of A Paint Line (Center to Center).

DETAIL NO. **2363** City of Scottsdale Standard Details

APPROVED BY: _____

PAVEMENT MARKERS FOR FIRE HYDRANTS

DETAIL NO. **2363**

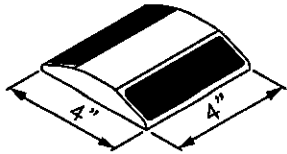

Type M Pavement Marker
(2-WAY REFLECTIVE BLUE)

DETAIL "A"

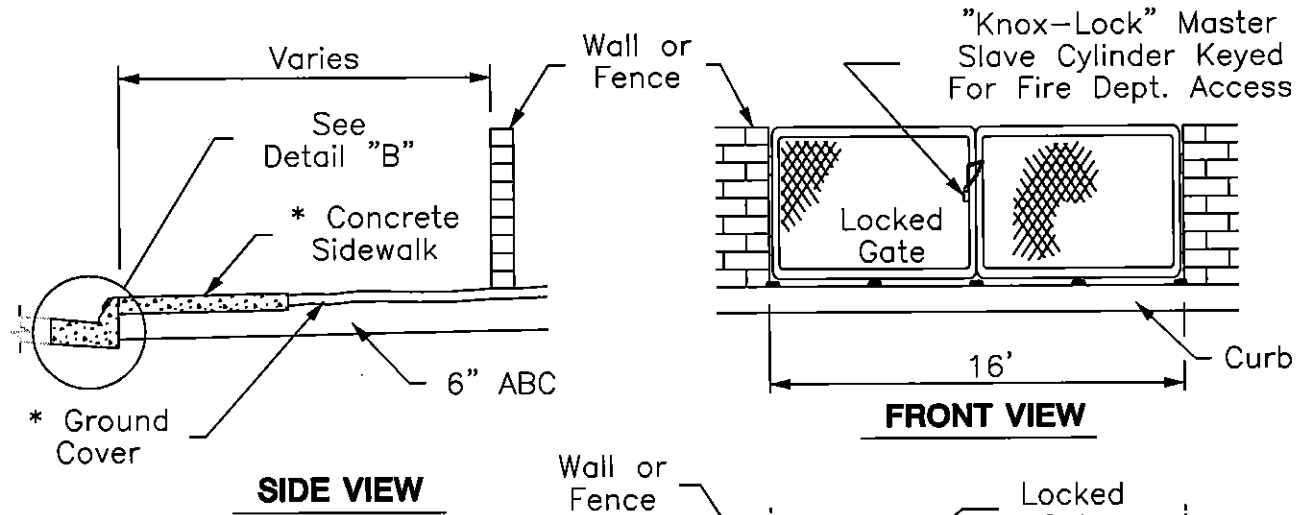

* NOTE:
Sidewalk And/Or 2"
Max. Ground Cover
Over Min. 6" ABC

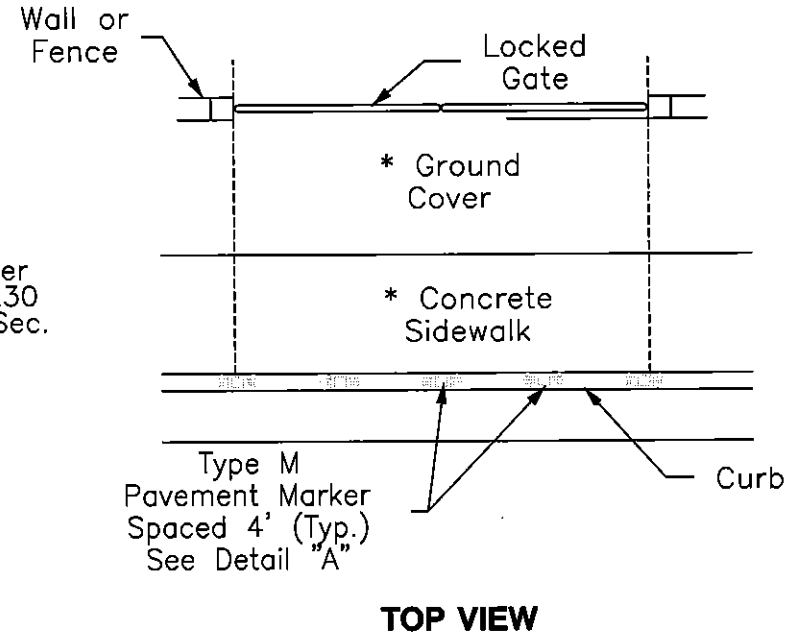
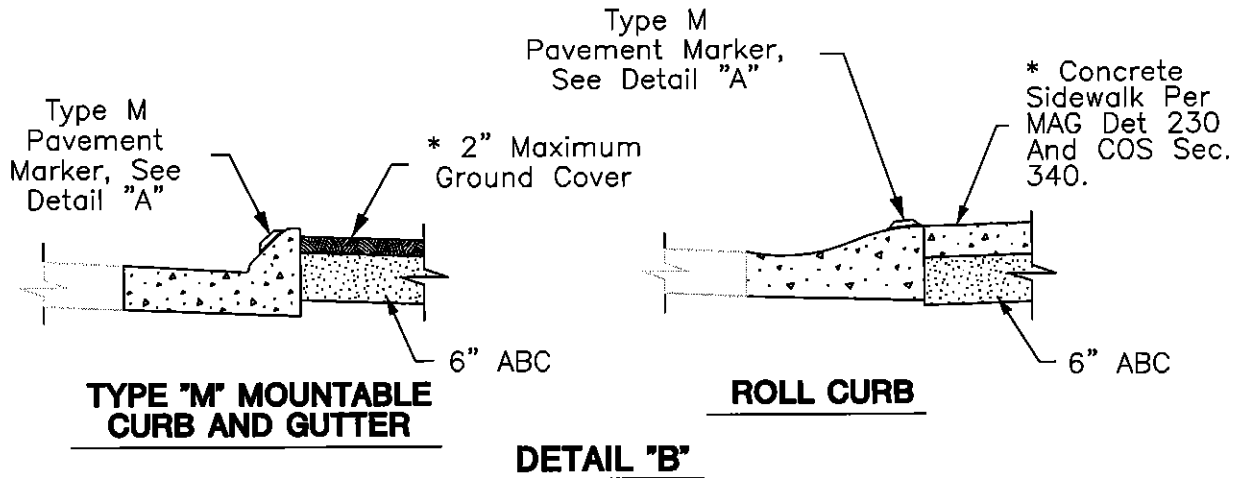

DETAIL NO. **2364** City of Scottsdale
Standard Details

APPROVED BY: _____

FIRE AND EMERGENCY ACCESS AND DELINEATION

DETAIL NO. **2364**

REVISED 2/20/01



NOTES:

1. At the beginning and end of the fire lane, the sign shall have a single headed arrow pointing in the direction the regulation is in effect. The intermediate signs shall have double headed arrows pointing in both directions.
2. The maximum spacing of the signs shall be 100', contingent upon Traffic Engineering's review and approval.
3. The signs shall be set at an angle of not less than 30° nor more than 45° with the curb or line of traffic flow
4. The clearance to the bottom of the sign shall be 7 feet. There shall be no other signs attached to the sign or the sign pole.
5. The sign plate shall be a minimum of 12" x 18" with a thickness of 0.80".
6. The sign face shall have a white, ASTM Type II (super engineering grade) reflective background with a red reflective legend. Use the standard sign face number R7-32 or equivalent incorporating additional information to complete the sign as shown above.

DETAIL NO.
2365

City of Scottsdale
Standard Details

FIRE LANE SIGN

DETAIL NO.
2365

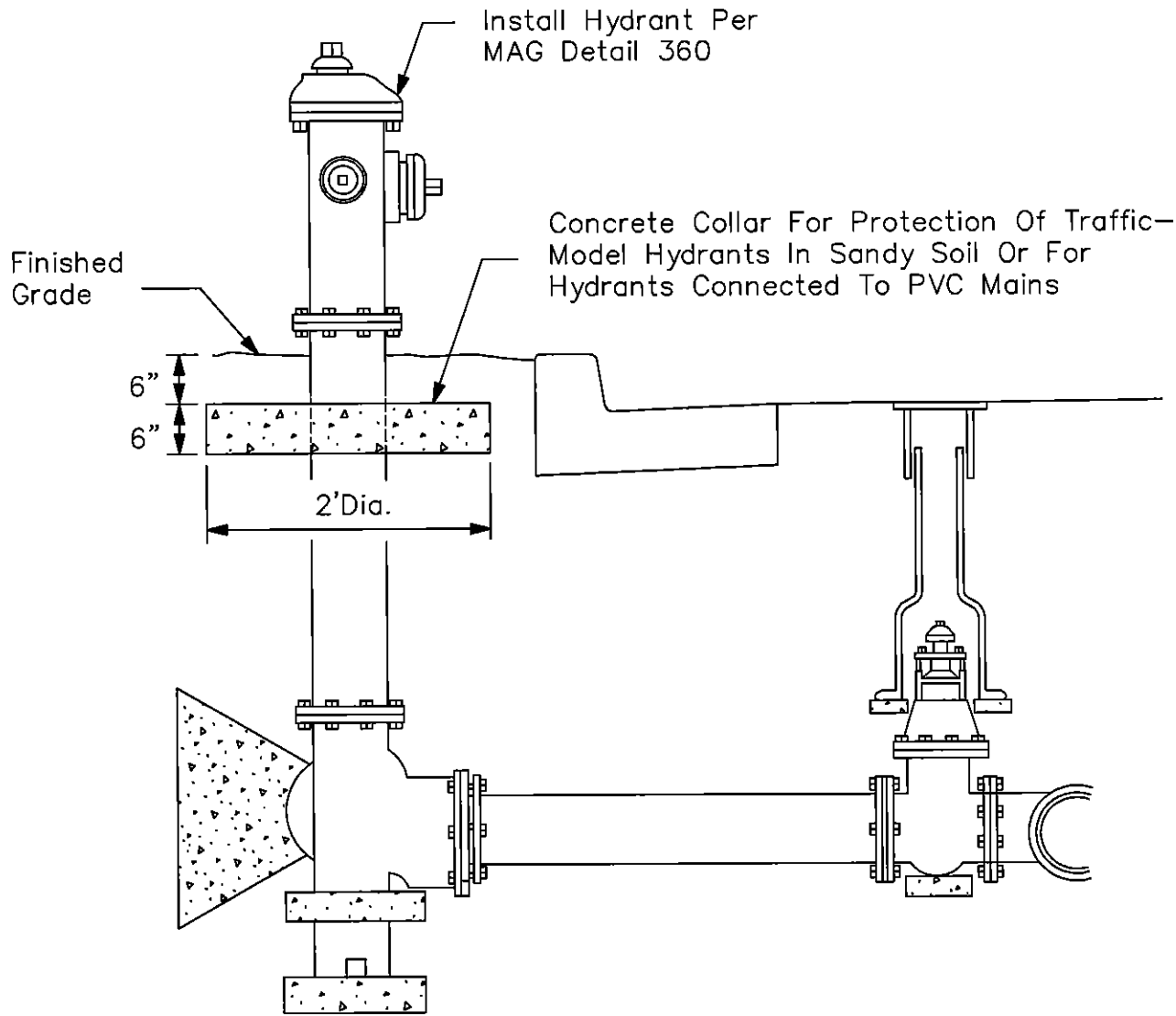

DETAIL NO.
2366

City of Scottsdale
Standard Details

CONCRETE COLLAR FOR FIRE HYDRANTS

DETAIL NO.
2366

AIR RELEASE AND SHUT-OFF VALVE (REQUIRED ON ALL LINES UNLESS OTHERWISE APPROVED BY WATER RESOURCES DEPARTMENT).

DUCTILE IRON PIPE. PIPE SHALL COMPLY WITH MAG SPEC'S, SECTION 750 AND SHALL HAVE POLYETHYLENE WRAP CORROSION PROTECTION PER MAG SECTION 610.5

AIR RELEASE AND SHUT-OFF VALVE (REQUIRED ON ALL LINES UNLESS OTHERWISE APPROVED BY WATER RESOURCES DEPARTMENT).

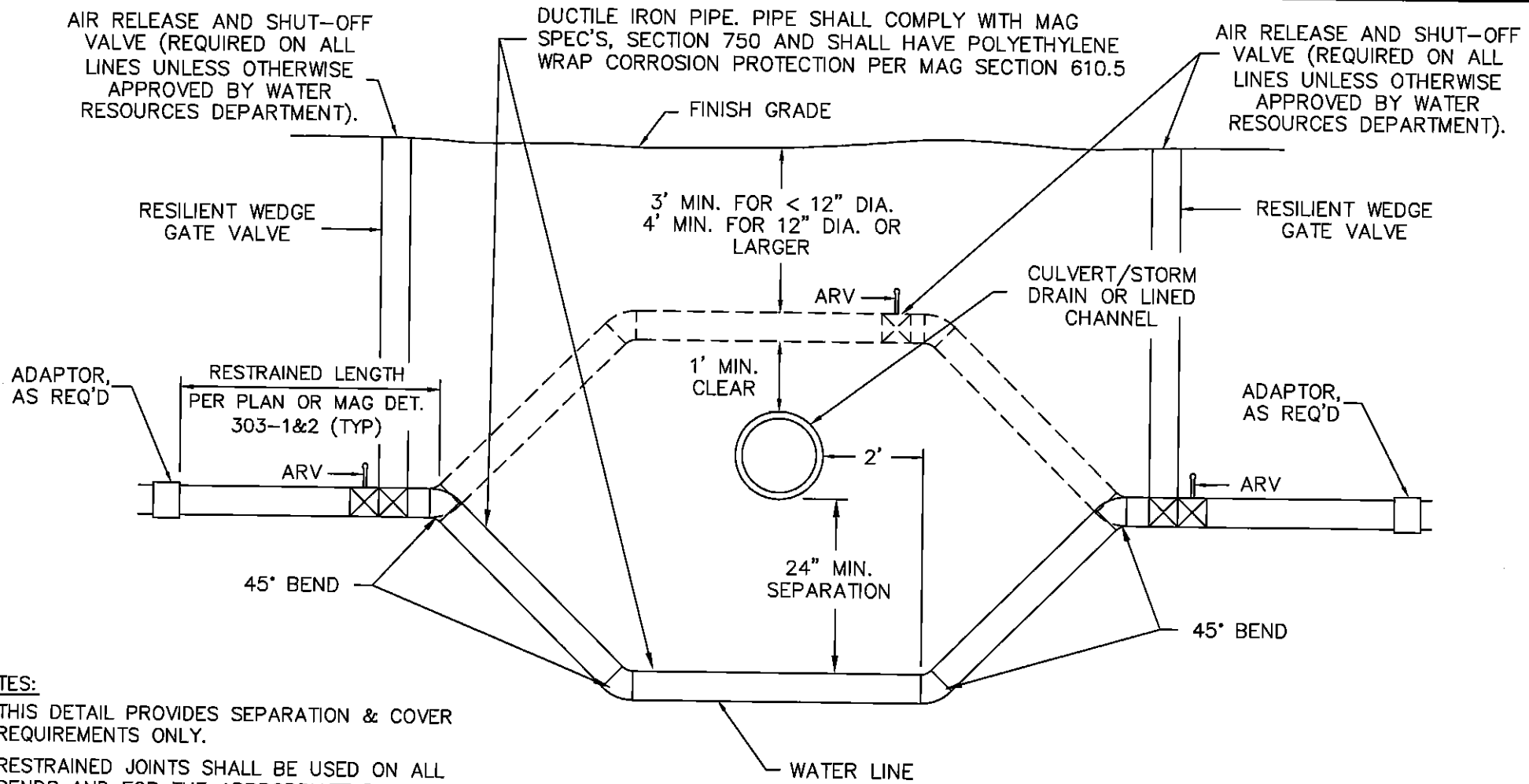

NOTES:

1. THIS DETAIL PROVIDES SEPARATION & COVER REQUIREMENTS ONLY.
2. RESTRAINED JOINTS SHALL BE USED ON ALL BENDS AND FOR THE APPROPRIATE RESTRAINT LENGTH OF PIPE PER THE MANUFACTURERS SPECIFICATION.

DETAIL NO. **2370** City of Scottsdale
Standard Details

VERTICAL REALIGNMENT OF WATER MAINS

DETAIL NO. **2370**

REVISED 8/29/96

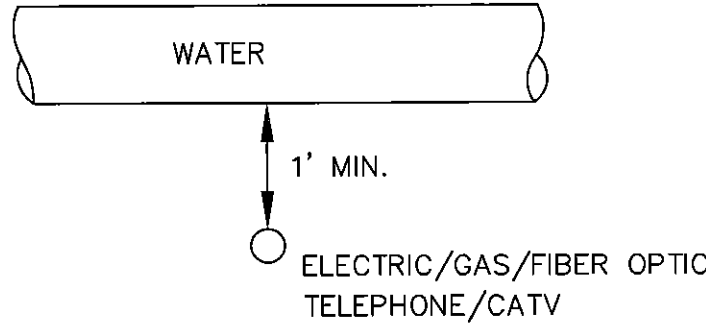
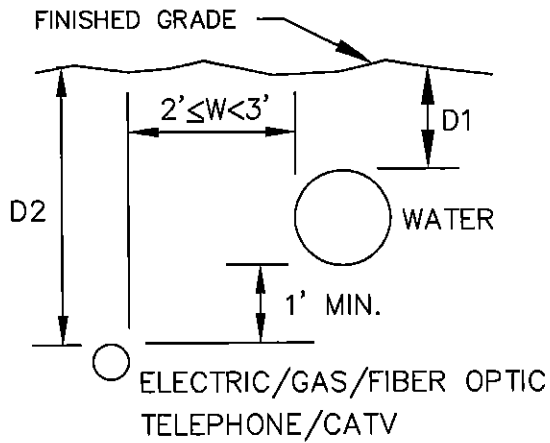

CROSSING

LEGEND

- D1 = 3' Min. for pipe < 12" dia
- D1 = 4' Min. for pipe ≥ 12" dia
- D2 = Minimum Cover
- W = Horizontal Separation

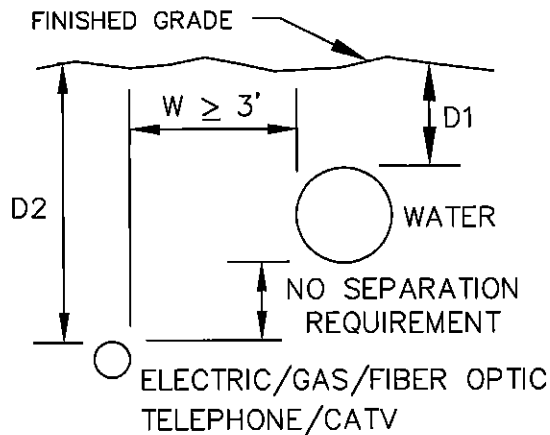

NOTES

1. Electric separation requirements are for primary electric conductors only. For service conductors see plans.
2. Primary electric, gas, telephone, cable TV or fiber optic lines shall not cross above a water line without written approval from the City's Water Resources Department. If this approval is obtained, a utility locator strip and ABC slurry conforming to COS Specifications Sec. 601.3.6 are required.

DETAIL NO. **2372** City of Scottsdale Standard Details

APPROVED BY: _____

MINIMUM UTILITY SEPARATION REQUIREMENTS

DETAIL NO. **2372**

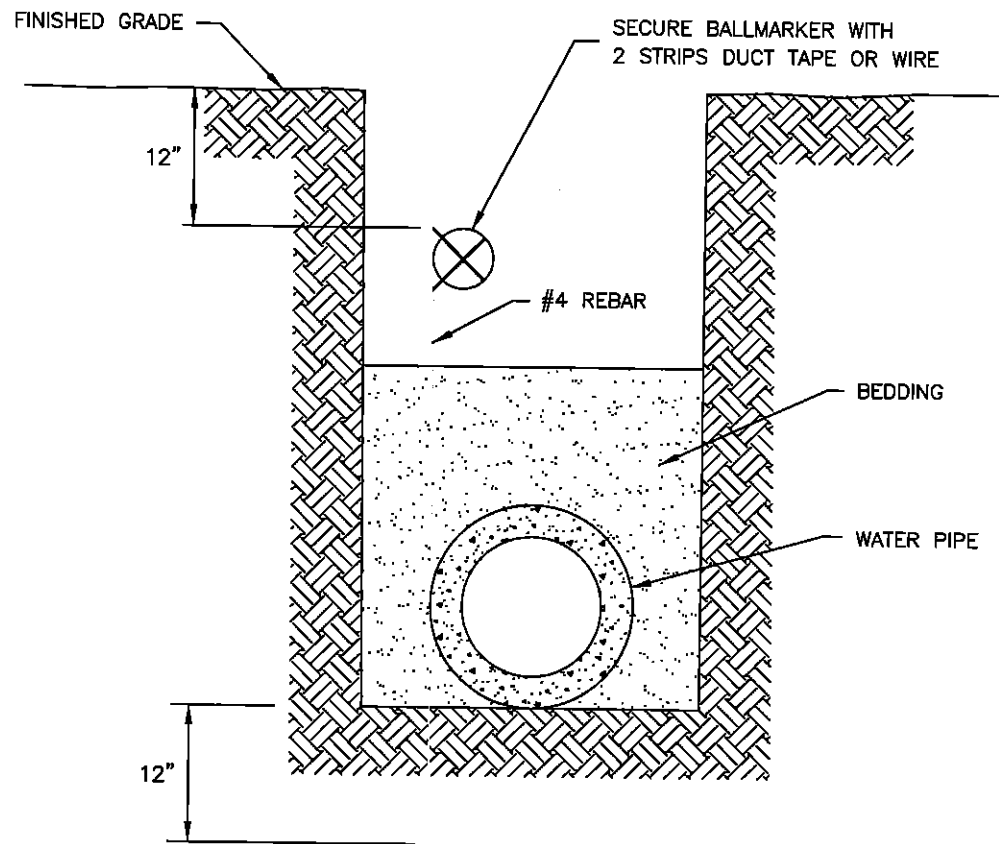

DETAIL NO.
2397 City of Scottsdale
Standard Details

ELECTRONIC BALLMARKER PLACEMENT

DETAIL NO.
2397

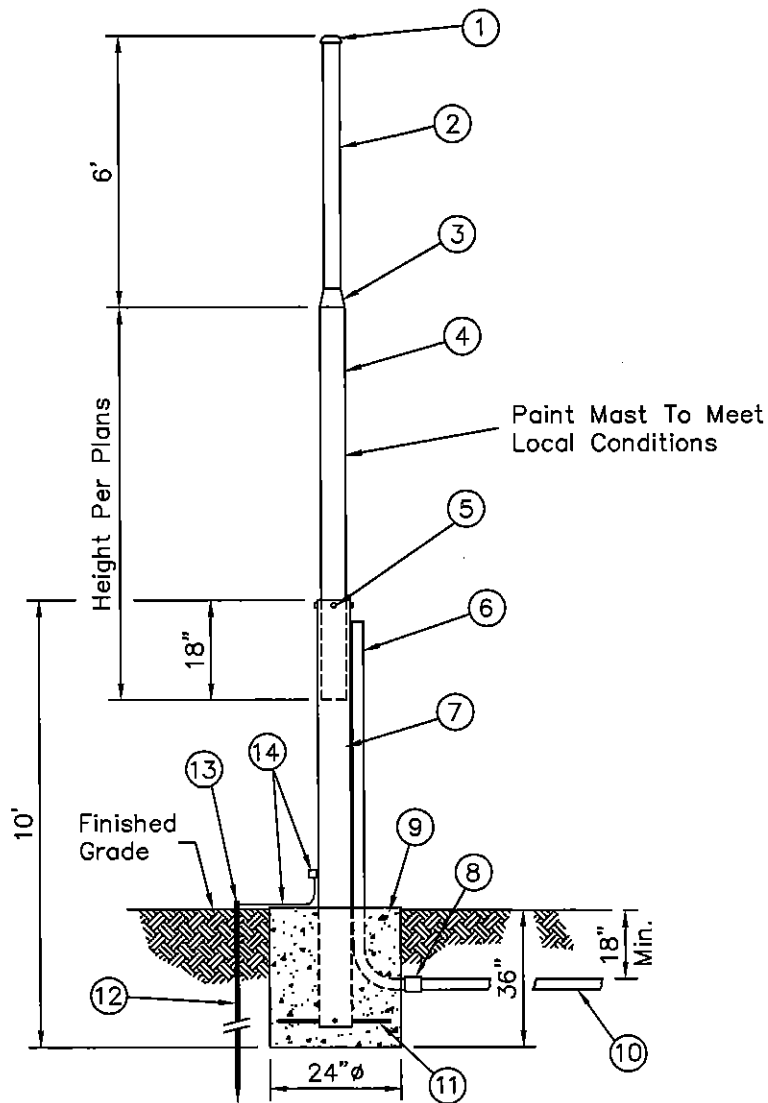

LIST OF MATERIALS

- ① Raintight Cap
- ② 2" Galvanized Rigid Steel Conduit
- ③ 2 1/2" To 2" Galvanized Steel Reducer
- ④ 2 1/2" Galvanized Rigid Steel Conduit
- ⑤ 1/2" Set Screw (Typ. - 4 Each)
- ⑥ 1" Rigid Steel Conduit, Strap To Mast
Install Bushing On Top Of Conduit
- ⑦ 3" Galvanized Rigid Steel Conduit
- ⑧ PVC To Rigid Steel Conduit Fitting
- ⑨ Concrete Foundation, Class "B"
- ⑩ 1" PVC Conduit To Radio Transceiving Unit
- ⑪ #5 Rebar (8" Length) Welded To
3" Conduit (Typ. - 4 Each)
- ⑫ 5/8" ϕ x 8' Long Grounding Rod
- ⑬ Acorn Nut Connection
- ⑭ Ground Attached To 3" Conduit
Using Lug And Self Tapping Screw

DETAIL NO.
2398

City of Scottsdale
Standard Details

APPROVED BY:

ANTENNA MAST DETAIL

DETAIL NO.
2398

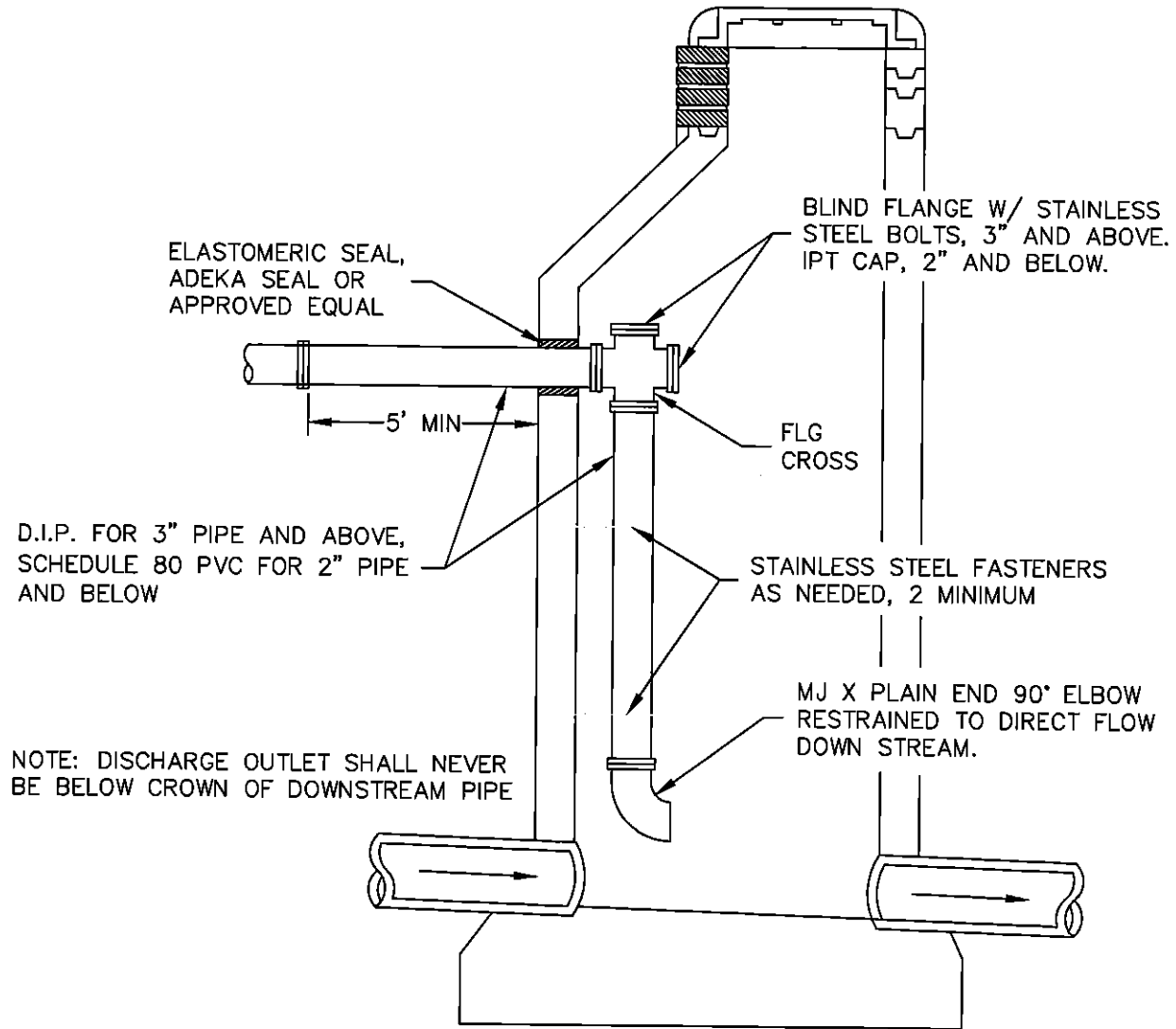

DETAIL NO.
2402

City of Scottsdale
Standard Details

FORCE MAIN DISCHARGE MANHOLE

DETAIL NO.
2402

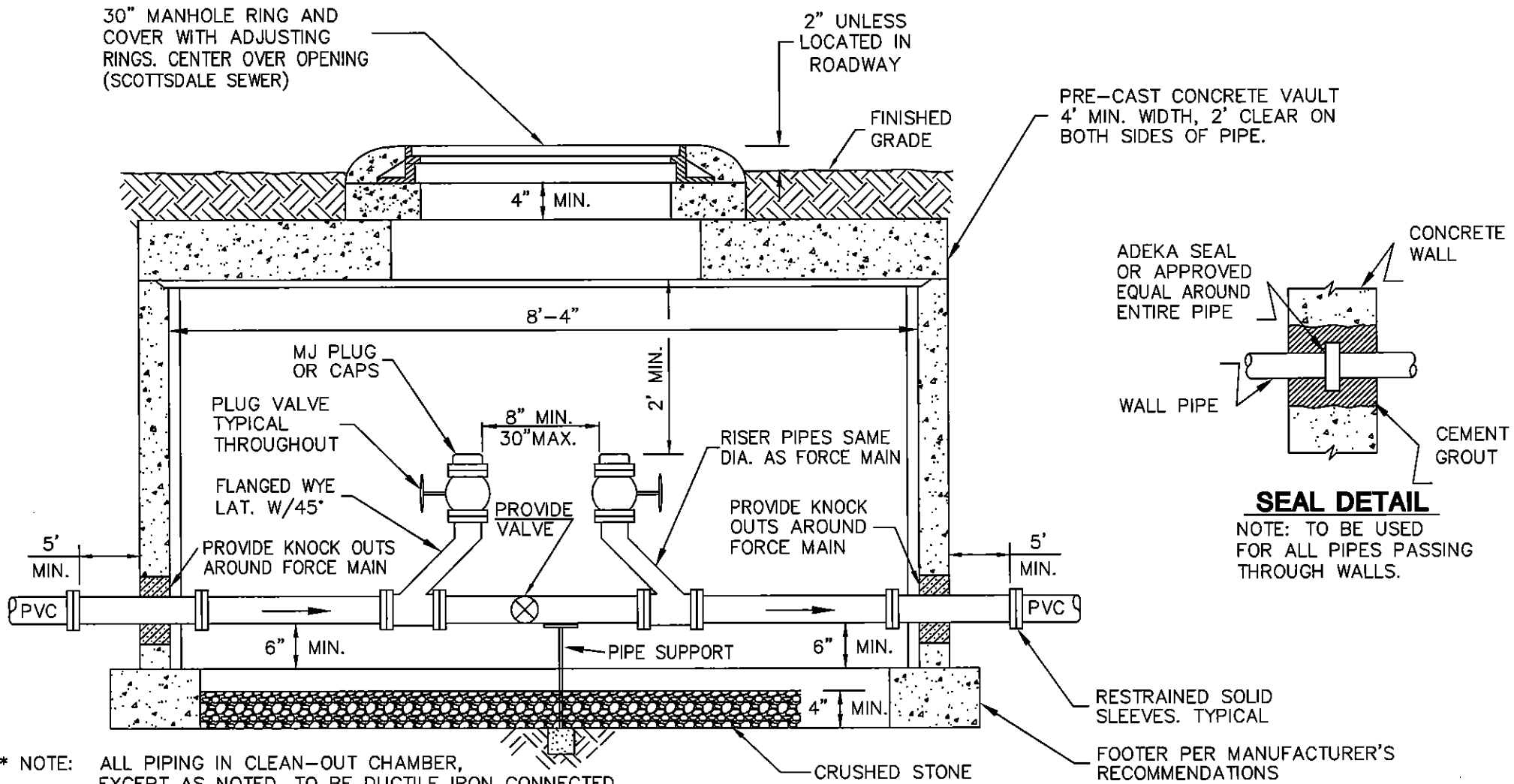

* NOTE: ALL PIPING IN CLEAN-OUT CHAMBER, EXCEPT AS NOTED, TO BE DUCTILE IRON CONNECTED WITH FLANGED JOINTS AND STAINLESS STEEL BOLTS.

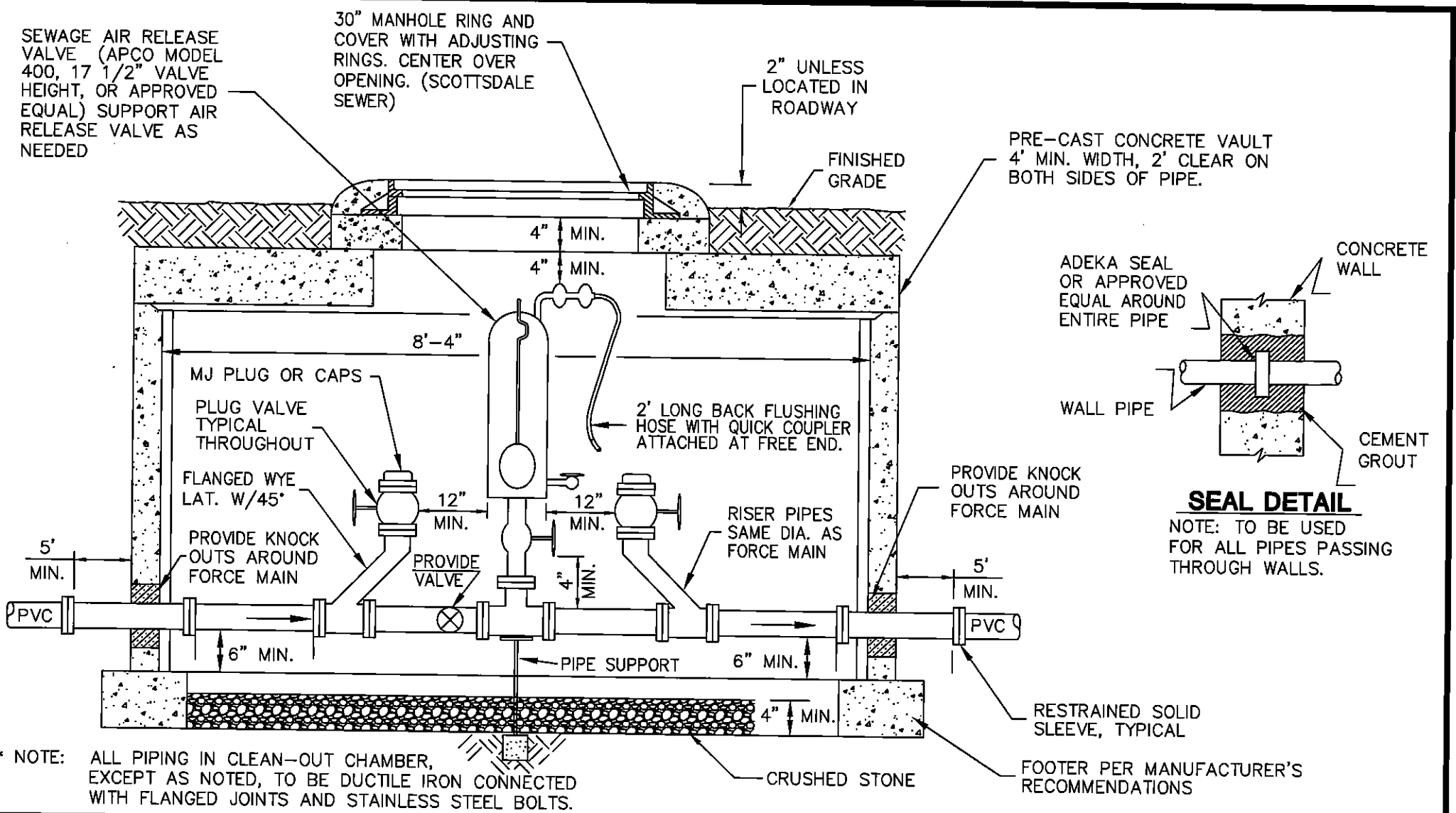

* NOTE: ALL PIPING IN CLEAN-OUT CHAMBER, EXCEPT AS NOTED, TO BE DUCTILE IRON CONNECTED WITH FLANGED JOINTS AND STAINLESS STEEL BOLTS.

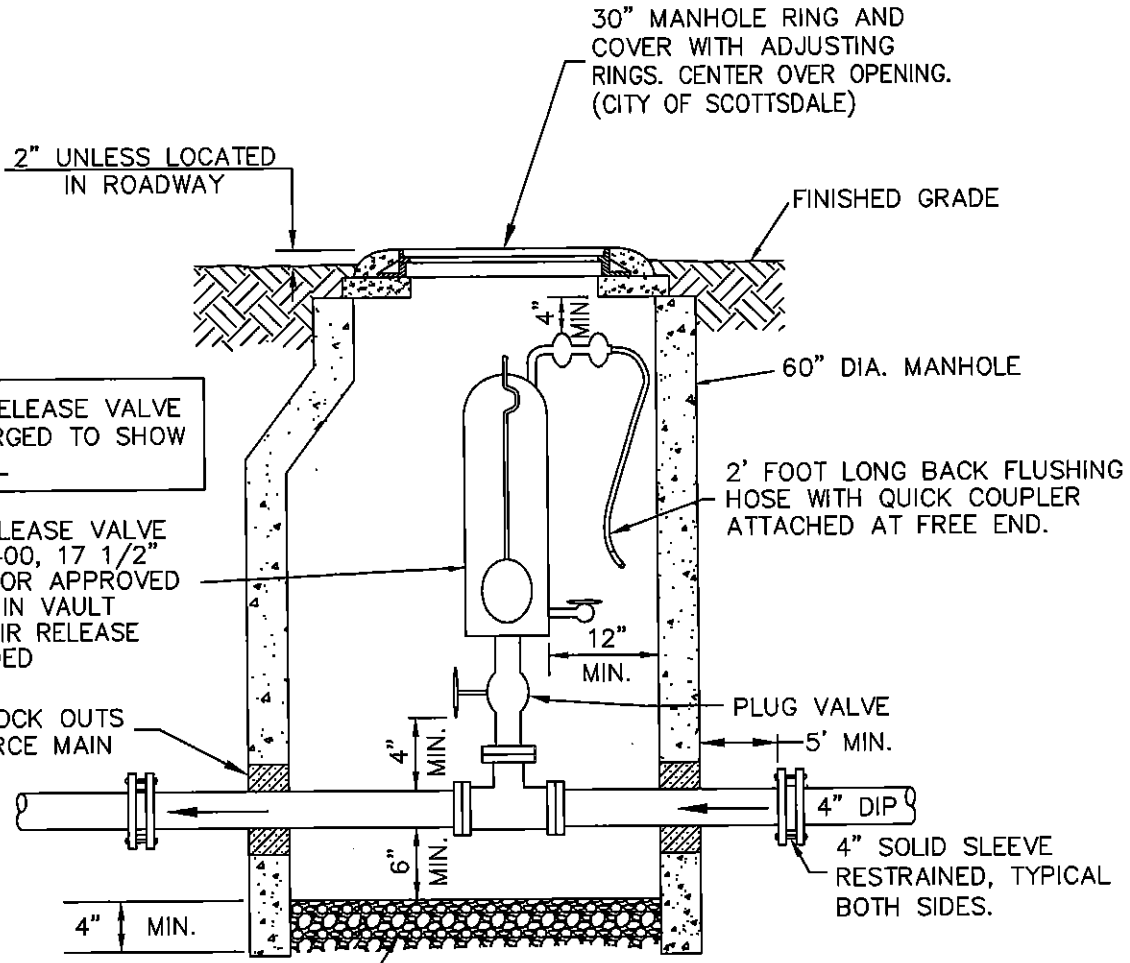

AIR RELEASE VALVE ENLARGED TO SHOW DETAIL

SEWAGE AIR RELEASE VALVE (APCO MODEL 400, 17 1/2" VALVE HEIGHT, OR APPROVED EQUAL) CENTER IN VAULT AND SUPPORT AIR RELEASE VALVE AS NEEDED

PROVIDE KNOCK OUTS AROUND FORCE MAIN

2" UNLESS LOCATED IN ROADWAY

30" MANHOLE RING AND COVER WITH ADJUSTING RINGS. CENTER OVER OPENING. (CITY OF SCOTTSDALE)

FINISHED GRADE

60" DIA. MANHOLE

2' FOOT LONG BACK FLUSHING HOSE WITH QUICK COUPLER ATTACHED AT FREE END.

12" MIN.

PLUG VALVE 5' MIN.

4" MIN.

6" MIN.

4" MIN.

4" SOLID SLEEVE RESTRAINED, TYPICAL BOTH SIDES.

CRUSHED STONE

* NOTE: ALL PIPING, EXCEPT AS NOTED, TO BE DUCTILE IRON WITH FLANGE JOINTS AND STAINLESS STEEL BOLTS.

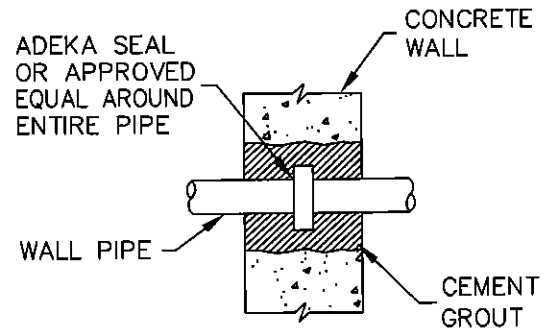

SEAL DETAIL

NOTE: TO BE USED FOR ALL PIPES PASSING THROUGH WALLS.

DETAIL NO. **2405** City of Scottsdale Standard Details

SEWER AIR RELEASE VALVE

DETAIL NO. **2405**

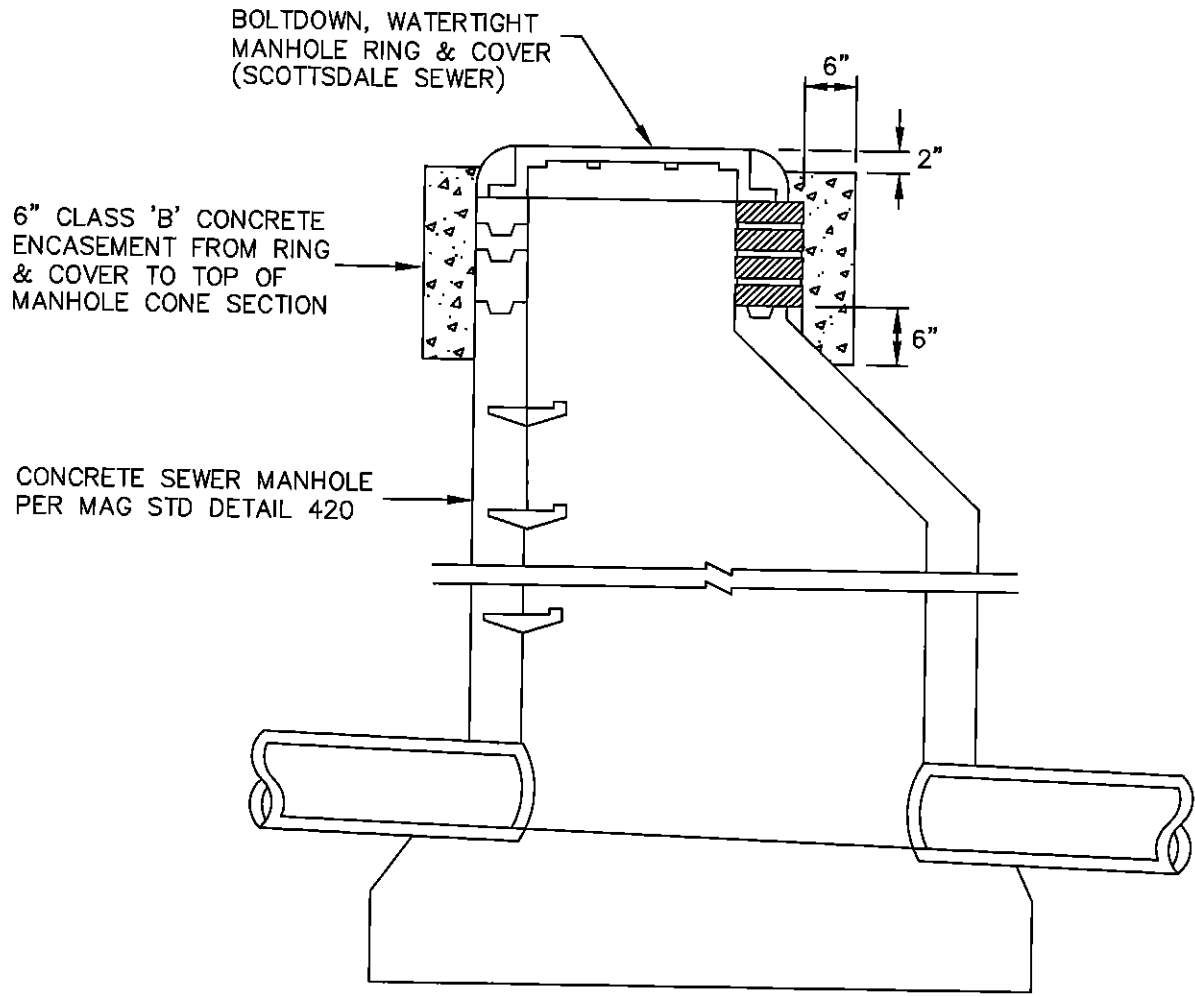

DETAIL NO.
2420 City of Scottsdale
Standard Details

WATER TIGHT CONCRETE SEWER MANHOLE

DETAIL NO.
2420

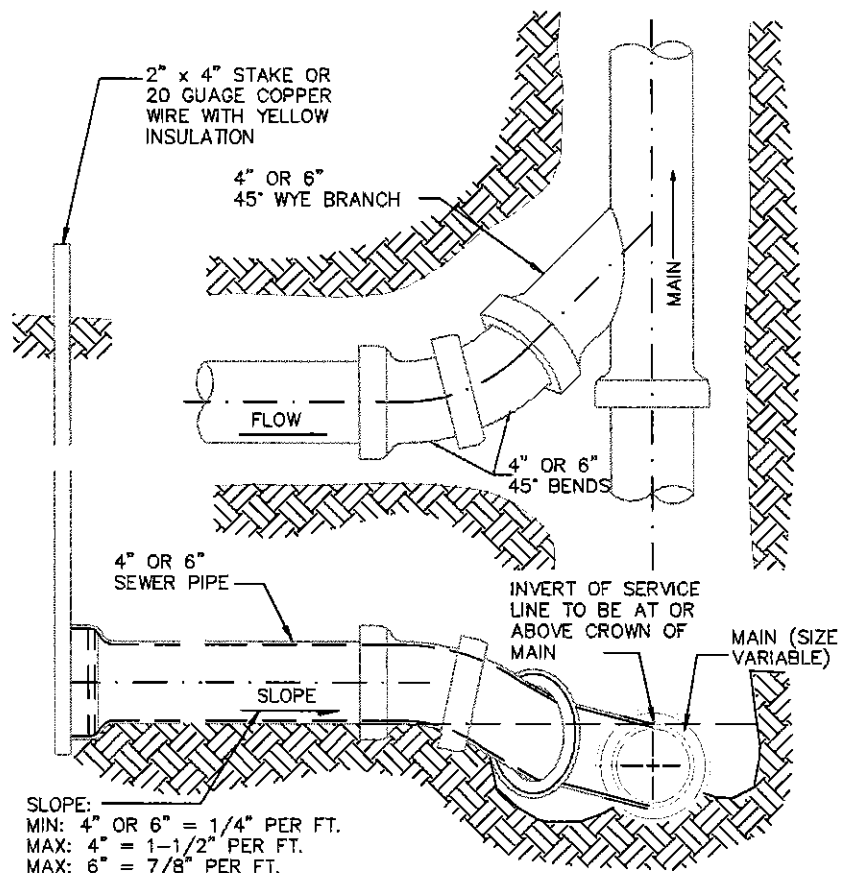

1. CONSTRUCTION DETAIL APPLIES WHERE CONTRACTOR BUILDS HOUSE CONNECTION. TAP EXTENDS TO PROPERTY LINE IN ALLEYS OR STREETS OR TO EASEMENT LINE.
2. SIZE OF TAP SHALL BE DESIGNATED ON PLANS.
3. CONSTRUCT TAP AT MINIMUM SLOPE IF COVER WILL BE LESS THAN 5' AT PROPERTY LINE.
4. IF DEPTH REQUIRES, MINIMUM SLOPE CAN BE REDUCED TO 1/8" PER FOOT PROVIDED STUB IS STAKED TO GRADE.

5. ALL FITTINGS SHALL BE INSTALLED IN ACCORDANCE WITH ASTM D-2321. THE CONTRACTOR MAY VARY FROM THE DRAWING TO USE THE APPROPRIATE WYES, TEE-WYES AND BENDS TO ENSURE NO MISALIGNMENT OF THE PIPE AND FITTINGS. BLOCK OR BRACE FITTING JOINTS TO ENSURE ZERO DEGREE'S ANGULAR JOINT DEFLECTION.

6. END OF TAP TO BE SEALED AND MARKED AS NOTED.

DETAIL NO.
2440

City of Scottsdale
Standard Details

SEWER BUILDING CONNECTION

DETAIL NO.
2440

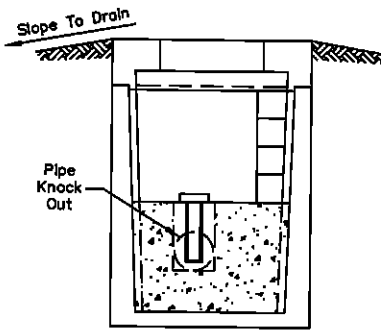

SECTION A-A

PRE-CAST VAULT
 UTILITY VAULT CO.
 VAULT NO. 575-BL,
 NO. 577-BL OR
 APPROVED EQUAL

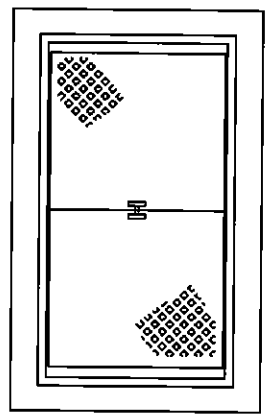

COVER WITH LID

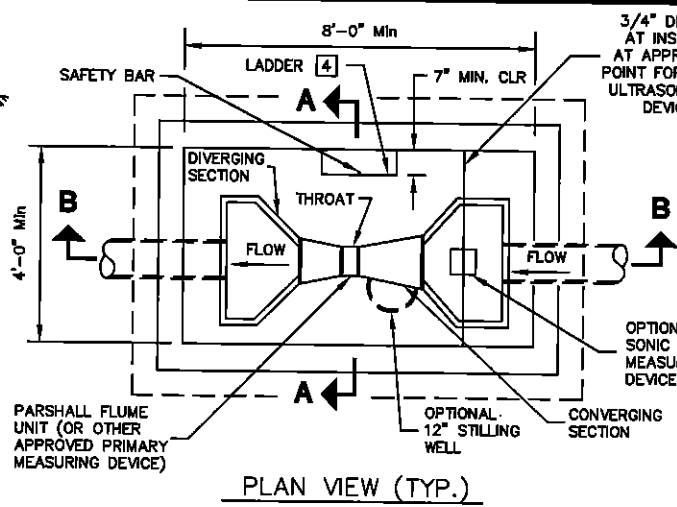

PLAN VIEW (TYP.)

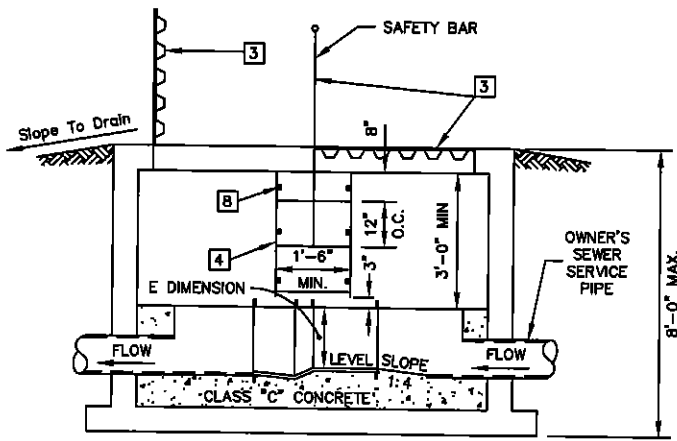

SECTION B-B

EQUIPMENT DESCRIPTION

A Fisher and Porter type 10F1940, Hinds Engineering Company, PS-1001, or approved equal molded fiberglass reinforced polyester Parshall Flume shall be installed. The flume shall be molded in one piece with ample wall thickness and reinforcing ribs to prevent distortion during shipment, installation and operation. The flume shall be self-supporting and require no external supporting structure. Interior dimensions shall conform to those in the latest revision of Water Measurement Manual published by the U.S. Department of the Interior, Water and Power Resources Services. The throat width and flume height ("E" dimension) shall be per plan.

3/4" DIA. SS ROD. FASTEN AT INSIDE WALL POSITION AT APPROPRIATE MEASURING POINT FOR "H" WHEN OPTIONAL ULTRASONIC FLOW MEASURING DEVICE IS INSTALLED.

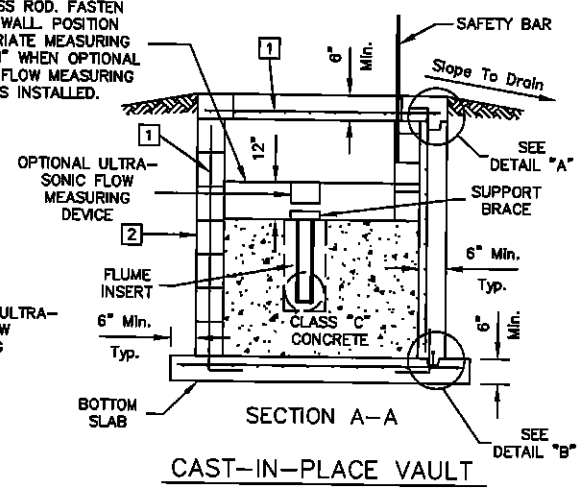

SECTION A-A

CAST-IN-PLACE VAULT

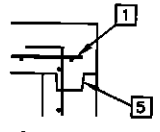

TOP KEY DETAIL "A"

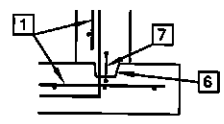

BOTTOM KEY DETAIL "B"

NOTES:

- 1 Reinforced steel and clearance as approved by the engineer.
- 2 Block masonry may be used in lieu of CIP walls. 8" block masonry, grout each call to full height (grout per MAG Section 776).
- 3 2 Torsion spring assisted galvanized diamond plate access doors (design loading AASHO-H20) locking with type 304SS hardware and safety bar (Bilco Model LU-3, or approved equal).
- 4 Ladder shall be furnished and installed in accordance with the detail and shall meet the requirements of OSHA for Type IA (300 lbs) fixed ladders, single section. Details of ladder construction, along with a certification that the ladder meets or exceeds OSHA requirements for Type IA (300 lbs) service shall be submitted for review prior to furnishing and installing. Mill finished aluminum ladder or approved corrosion resistant material.
- 5 2"x 4" key, center on wall. (Install rope caulk continuously).
- 6 1-5/8"x 2-1/2"x 3" key.
- 7 4" PVC dumbbell type continuous watertop 3/8" min. thickness. (Wash thoroughly prior to installation).
- 8 Anchor straps (3 each side) with 5/8" x 3-1/2" 316SS anchor bolts with lock washer and nut.

GENERAL NOTES

1. All construction shall conform to MAG Specifications and Details and City of Scottsdale Supplement to MAG Specifications and Details, unless modified on the plans.
2. All concrete floors, walls and top slab of the structure shall conform to MAG section 725, Class A, minimum compressive strength at 28 days = 3,000 psi.
3. All concrete for the grout fillet inside the structure shall conform to MAG Section 725, Class C, minimum compressive strength at 28 days = 2,000 psi.
4. All steel reinforcing shall be deformed bars, Grade 60, billet steel conforming to ASTM Specification No. A-615, latest edition.
5. The Monitoring/Sampling Vault shall be installed on the owner's property as close to the customer tap to the City sewer as feasible, and approved by the City of Scottsdale.
6. Flume size should be based upon the minimum and maximum flow rates and velocities to insure free-flow conditions.
 - Maximum Flow = 70%-100% of maximum capacity of selected flume size.
 - 0.5 inches of flow should exist at the minimum actual flow.
7. Flume floor elevation should be high enough, relative to downstream conditions, to prevent submerged flow (50% submergence is acceptable at maximum flow), install the flume level (longitudinally and transversely) in the converging section.
8. Upstream flow should be wave free, non-turbulent, and symmetrical having a uniform velocity (1fps minimum to 3 fps maximum) at least 10 times the diameter of the upstream sewer pipe in length in the approach channel. Bends upstream in the flume will NOT be allowed for a distance of 25 pipe diameters unless conditions in the approach section of the flume will not be adversely affected.
9. The flume shall be installed off-center and away from the ladder to allow the maximum working space for City personnel.
10. It shall be the owner's responsibility to properly maintain the flume in accordance with the manufacturers recommendations to ensure the accuracy of the measurement.

DETAIL NO. **2460** City of Scottsdale Standard Details

APPROVED BY: _____

MONITORING/SAMPLING VAULT

DETAIL NO. **2460**

REVISED 3/26/02

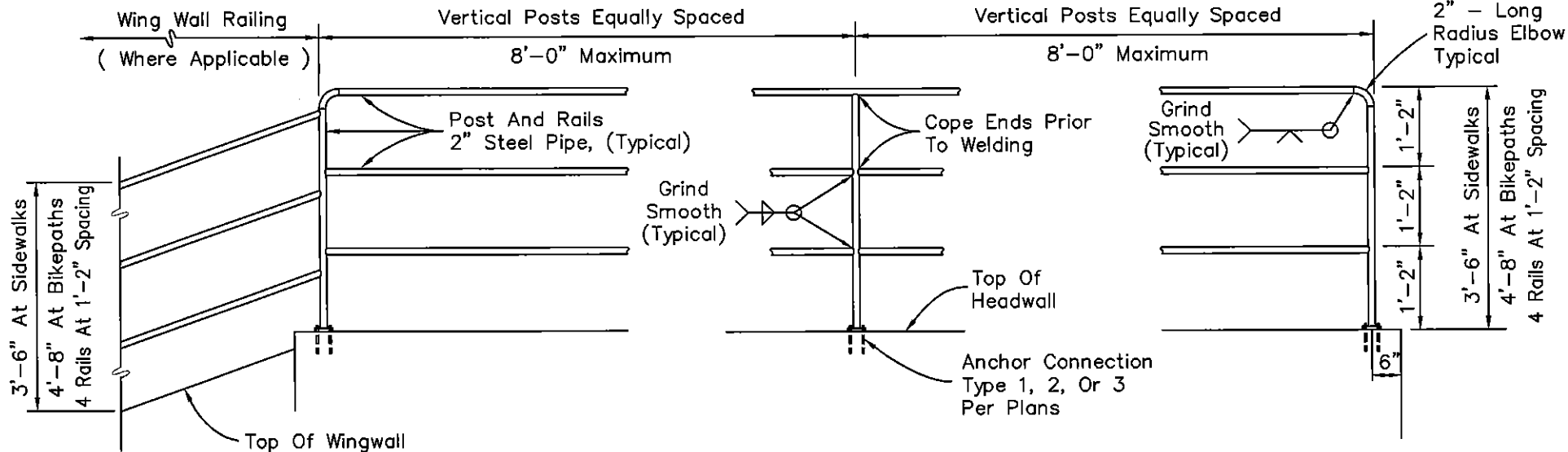

ELEVATION

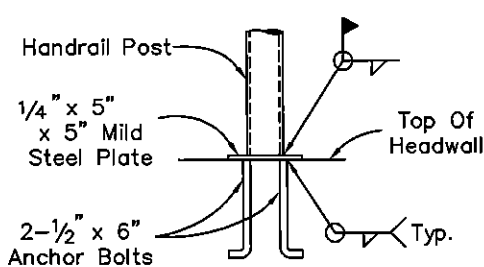

TYPE 1
ANCHOR PLATE DETAIL

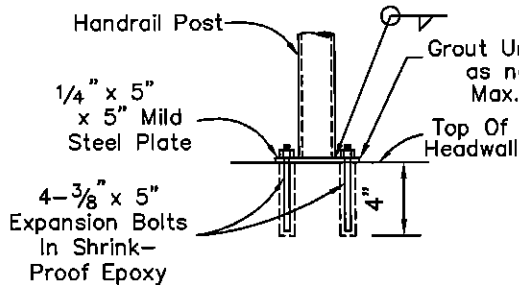

TYPE 2
EXPANSION BOLT DETAIL

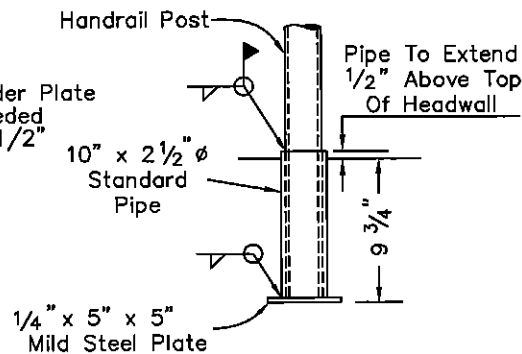

TYPE 3
PIPE SLEEVE DETAIL

CONSTRUCTION NOTES

1. Paint handrail per MAG Specifications Section 530. Color per plans.
2. Vertical posts to be evenly spaced.

DETAIL NO.
2508

City of Scottsdale
Standard Details

HANDRAIL DETAIL

DETAIL NO.
2508

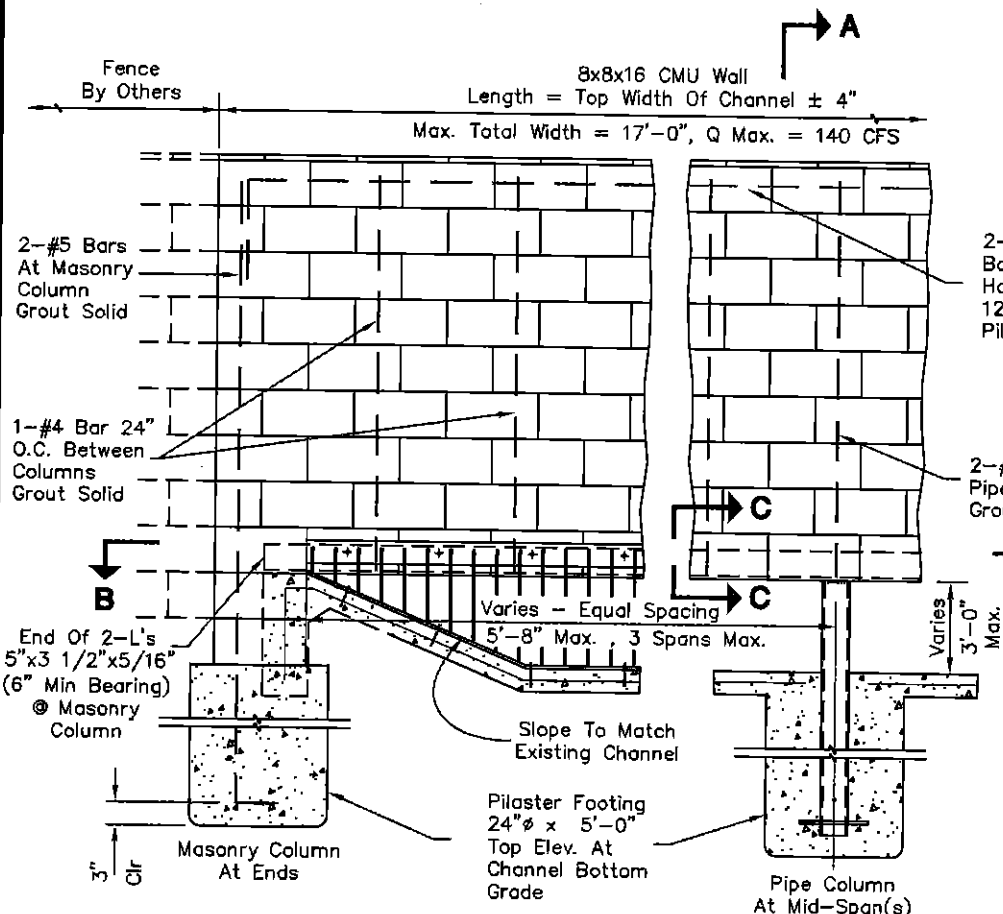

- WALL NOTES:**
1. Wall Height, Finish Texture And Color to Match Adjacent Property Wall.
 2. Construction To Conform to MAG Section 510.
 3. Trash Rack Grate Required on Private Lots only; And Property Owner Shall Be Responsible for Cleaning.

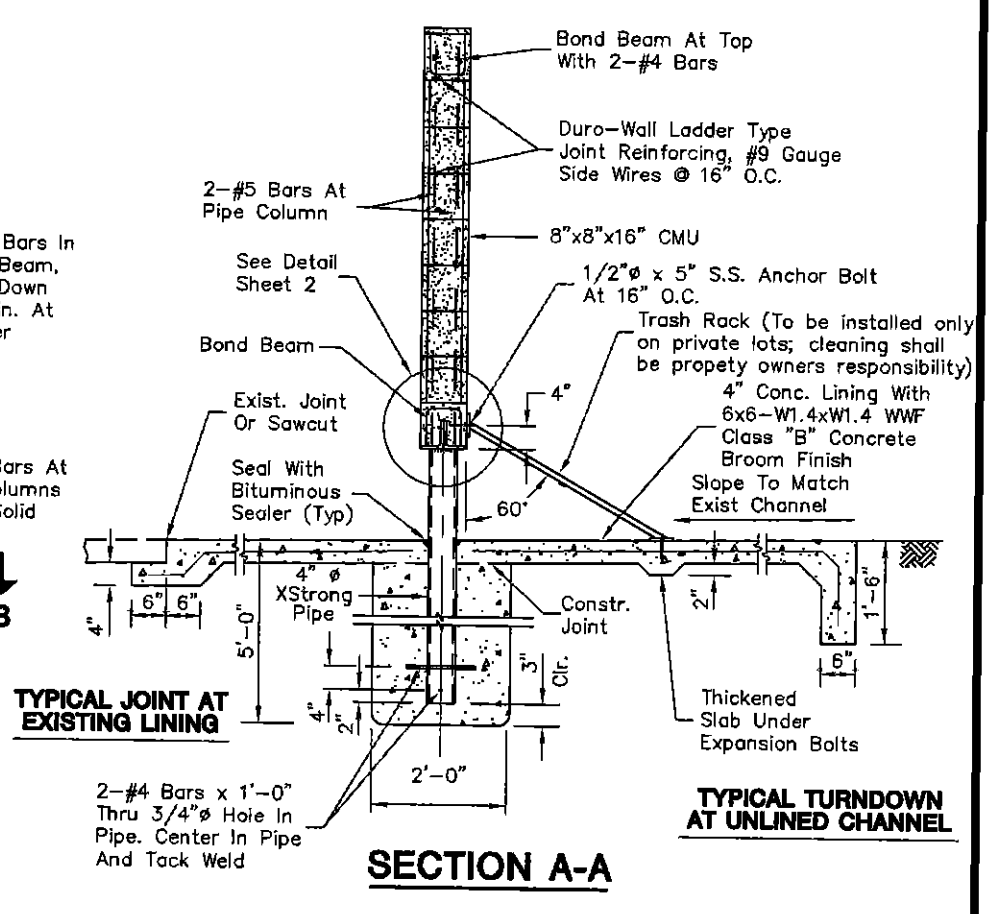

- CHANNEL NOTES:**
- UNLINED CHANNELS:** Construct New Lining 6' Minimum Upstream And Downstream From Wall With Turndown At All Edges Of Lining.
- EXISTING LINED CHANNELS:** Remove Existing Lining 4' Minimum Upstream And Downstream From Wall. Replace Using Joint Shown.

DETAIL NO. **2515-1** City of Scottsdale
Standard Details

WALL OPENING & EROSION PROTECTION - TYPE 1

SHEET 1 OF 2
DETAIL NO. **2515-1**

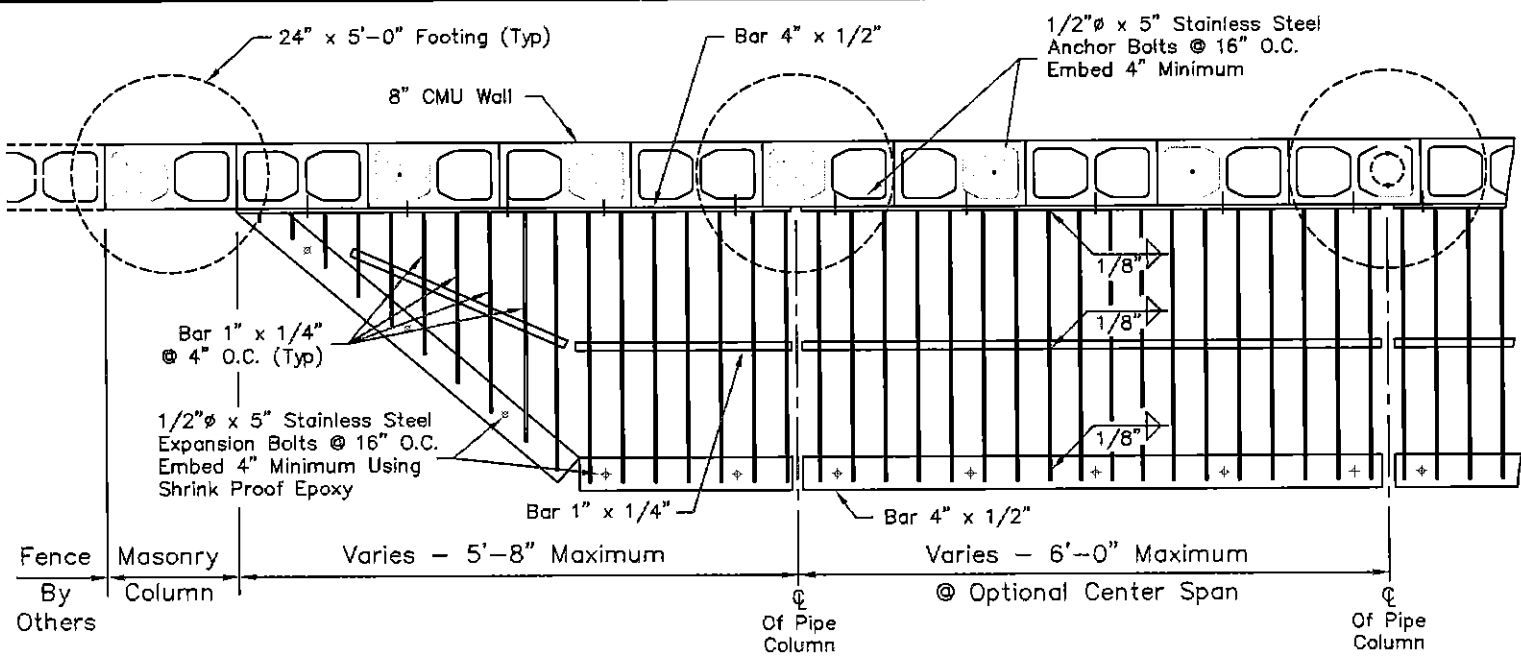

SECTION B-B

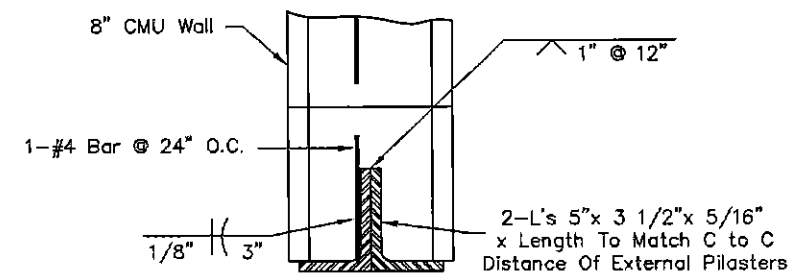

SECTION C-C

GRATE NOTES:

1. Steel Work Shall Conform To Mag Sections 515 And 770.
2. Shop Drawings Are Not Required. Contractor Shall Be Responsible For Correct Fit Between The Trash Rack, Channel And Wall As Constructed In The Field.
3. Shop Prime Steel And Touch-Up Per MAG Section 515.5. Apply A Second Coat After Erection And A Finish Coat Of Alkyd Enamel To Match Wall Finish Color.
4. Grate Required on Private Lots Only. Property Owner Responsible for Cleaning.

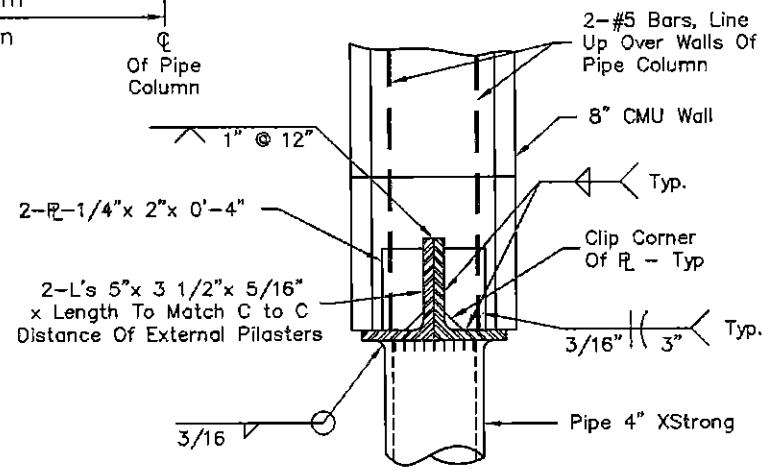

DETAIL AT PIPE COLUMN

DETAIL NO. **2515-2** City of Scottsdale Standard Details

DRAINAGE GRATE AT BLOCK WALL

SHEET 2 OF 2
DETAIL NO. **2515-2**

Top Stone:
Loose Naturally Placed
Native Stone. $D_{50} = 8"$
(Size: 3" Min. - 12" Max.)

Note: Stone shall
be fractured with
angular faces; no
river run

Bed Stone:
Hand Placed Native Stone
 $D_{50} = 15"$ (Size: 12" Min. -
18" Max.)

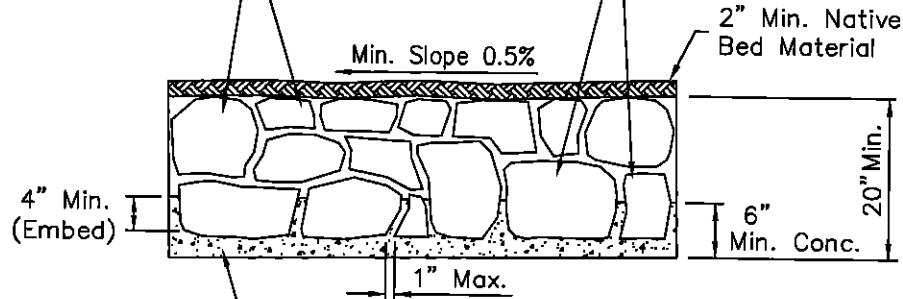

Integrally Colored Concrete Or
Grout, Color To Be Determined By
Plans or City Of Scottsdale Inspector
(Color to match native stone)

TYPE 1 - BURIED GROUDED RIP-RAP DETAIL

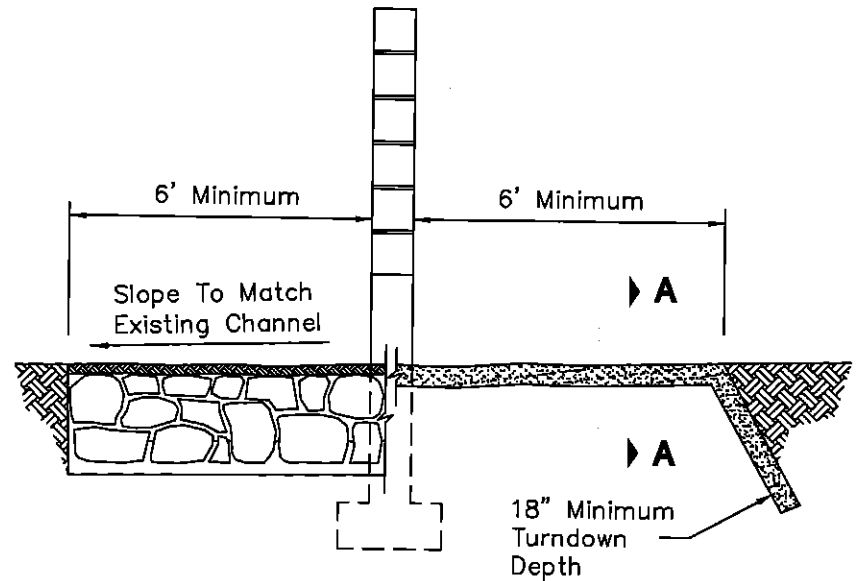

SECTION AT WALL

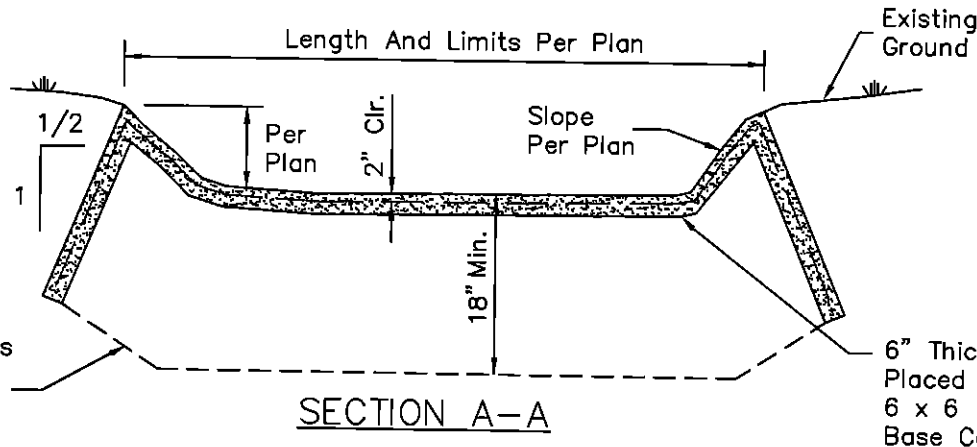

TYPE 2- PNEUMATICALLY PLACED MOTAR DETAIL

DETAIL NO.
2515-3 City of Scottsdale
Standard Details

WALL OPENING EROSION PROTECTION

DETAIL NO.
2515-3

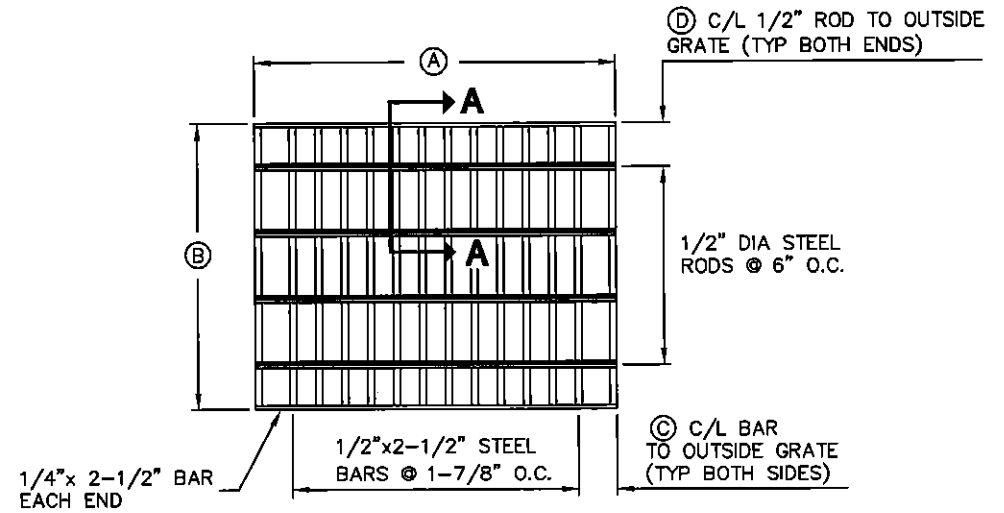
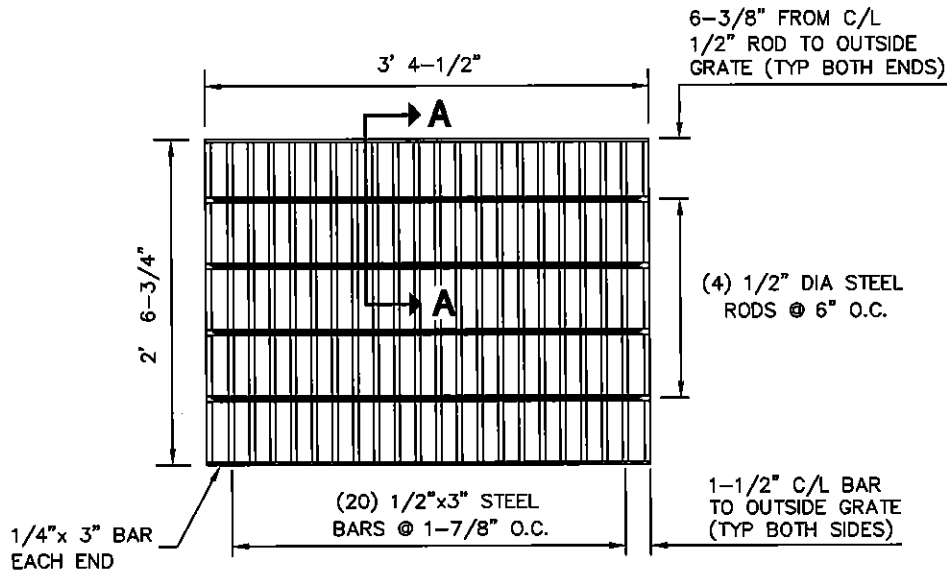

GRATE FOR TYPE 'F' CATCH BASIN
REPLACES GRATE SHOWN IN MAG DETAIL NO 535

GRATE FOR TYPE 'G' CATCH BASIN
REPLACES GRATE SHOWN IN MAG DETAIL 537

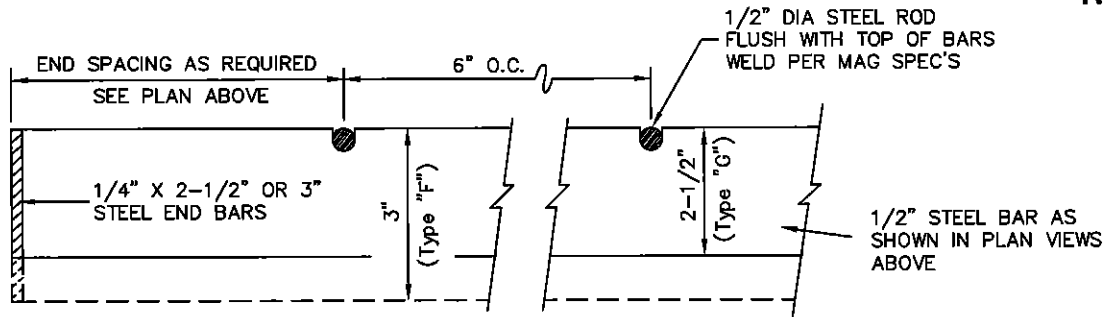

SECTION A-A

NOTES:

1. ALL MATERIALS AND FABRICATION TO BE AS SPECIFIED IN MAG STANDARD DETAIL NO. 540-2

TYPE "G" GRATE DIMENSIONS		
	SINGLE GRATE	DOUBLE GRATE
(A)	2'-2"	4'-3 1/2"
(B)	2'-2"	2'-2"
(C)	2-11/16"	2-5/16"
(D)	0'-4"	0'-3 3/4"

DETAIL NO. **2535** City of Scottsdale
Standard Details

APPROVED BY: _____

CATCH BASIN GRATES

DETAIL NO. **2535**

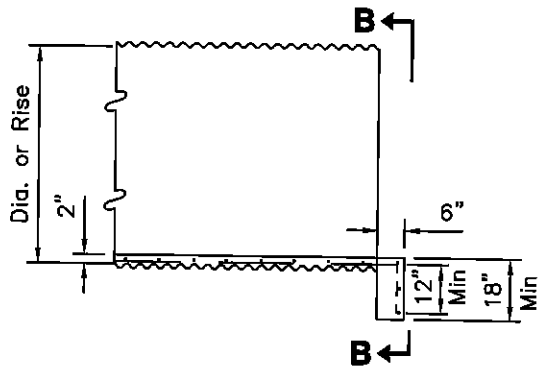

NO HEADWALL

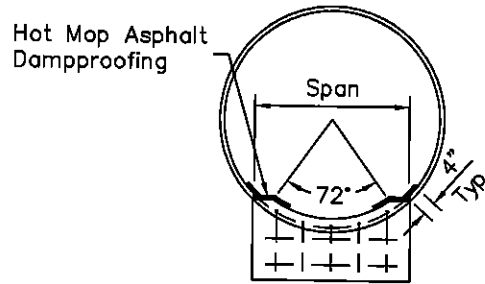

ELEVATION B-B

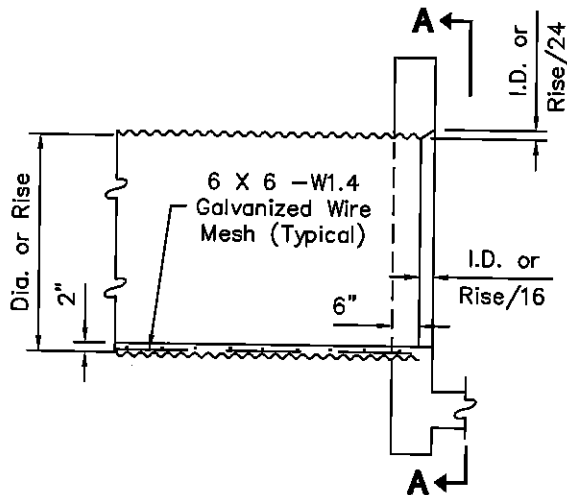

WITH HEADWALL

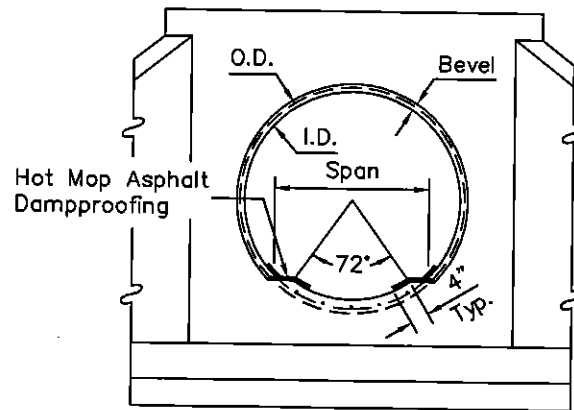

ELEVATION A-A

GENERAL NOTES

1. For lateral dimensions of invert paving, use 72° control for CMP and span for CMPA.
2. Paving shall be scored at 18" min. (transverse) along pipe length.
3. Use bevel on inlet headwall only.
4. Wire mesh shall be tack welded to corrugation crests at 18" intervals. Laps shall be 6" min.
5. Paving shall not be placed until backfilling is completed.
6. Concrete shall be Class "B".

DETAIL NO.
2564

City of Scottdale
Standard Details

APPROVED BY:

CONCRETE INVERT PAVING FOR
CORRUGATED METAL PIPE AND PIPE ARCH

DETAIL NO.
2564

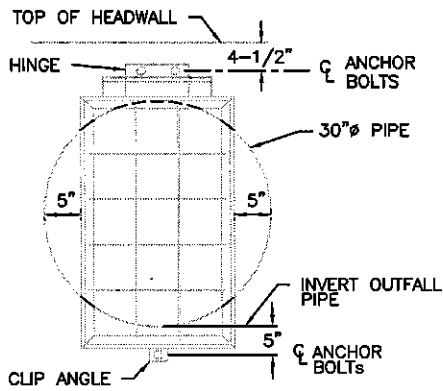

30" & 36" PIPES ONLY, SINGLE HINGE & CLIP ANGLE DETAIL

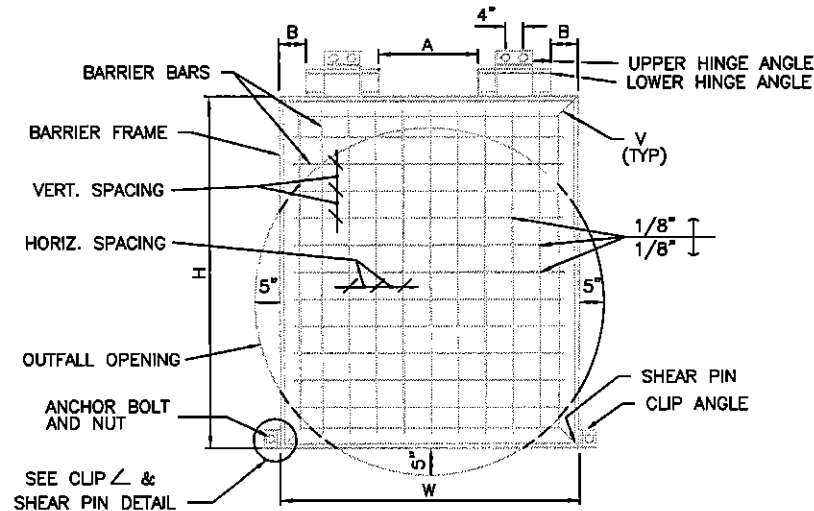

TYPICAL BARRIER DETAIL

HINGE PIN

BOLT STOCK, THREAD BOTH ENDS SO NUT & LOCK WASHER ARE FLUSH WITH LOWER ANGLE, UPSET OR DAMAGE EXPOSED THREADS. COAT PIN WITH WATERPROOF GREASE BEFORE INSTALLATION.

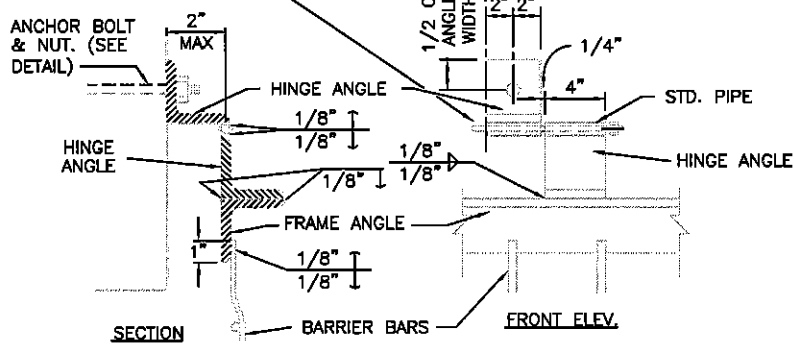

HINGE INSTALLATION DETAIL

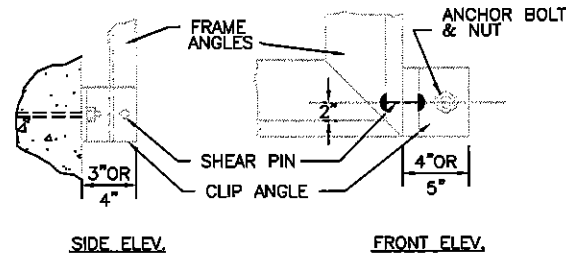

CLIP ANGLE & SHEAR PIN DETAIL

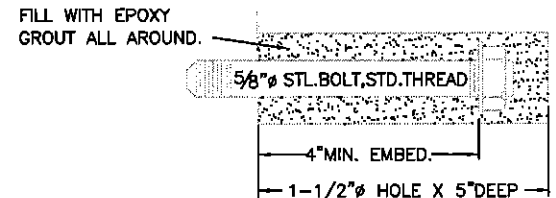

ANCHOR BOLT DETAIL

NOTES:

1. ALL SHEAR PIN ANGLES SHALL FIT SNUGLY AND TRULY FACE TO FACE. COVER WITH WATERPROOF GREASE PRIOR TO INSTALLATION OF PIN.
2. GALVANIZE ALL FERROUS PARTS AFTER FABRICATION.
3. THE SHEAR PIN HOLES IN THE ANGLE SHALL BE DRILLED FOR A TIGHT FIT OF THE SHEAR PINS.
4. FRAME AND HINGE ANGLES SHALL HAVE THE OUTSTANDING LEGS OUT FOR OUTLETS.
5. ALL ANCHOR BOLTS SHALL BE 5/8" ANCHOR BOLTS EMBEDDED 4" (MIN.) INTO EPOXY GROUT.
6. ALL SHEAR PINS ARE TO BE PEENED BOTH ENDS AFTER INSTALLATION.
7. SHEAR PIN MATERIAL SHALL BE COMMERCIAL PURE ALUMINUM WIRE.
8. SEE BARRIER SCHEDULE, DET. 2562-2 FOR VARIABLE DIMENSIONS.
9. COVER ALL MOVABLE CONTACT SURFACE WITH A COAT OF WATERPROOF GREASE PRIOR TO INSTALLATION.
10. ALL BARRIER BARS TO BE 1/2" PLAIN.

DETAIL NO. **2562-1** **City of Scottsdale**
Standard Details

APPROVED BY: _____

STORM SEWER OUTFALL ACCESS BARRIER 2562-1

DETAIL NO. **2562-1**

SIZE OF OUTFALL CONDUIT	FRAME ANGLES	SHEAR PIN CLIP ANGLES	SHEAR PINS	HINGE PINS	HINGE ANGLES	HINGE STD. PIPE	* NO. OF EQUAL BARRIER BAR SPACES (HORIZ.)	NO. OF EQUAL BARRIER BAR SPACES (VERT.)	H (OUT TO OUT FRAME ANGLES)	* W (OUT TO OUT FRAME ANGLES)	A	B
30"	2X2X1/4	4X4X1/4	1-1/8 ϕ	1/2" ϕ	2X2X1/4	3/4"	3	5	34"	20"	SINGLE HINGE CENTERED	
36"	2X2X1/4	4X4X1/4	1-1/8 ϕ	3/4" ϕ	2-1/2X 2-1/2X1/4	1"	4	6	40"	26"	SINGLE HINGE CENTERED	
42"	2X2X1/4	4X4X1/4	2-1/8 ϕ	1/2" ϕ	2X2X1/4	3/4"	5	6	42"	32"	0	0
48"	3X3X7/16	5X3X1/4	2-1/8 ϕ	3/4" ϕ	2-1/2X 2-1/2X1/4	1"	5	7	47"	38"	3"	1"
54"	3X3X7/16	5X3X1/4	2-1/8 ϕ	3/4" ϕ	2-1/2X 2-1/2X1/4	1"	6	8	54"	44"	5"	3"
60"	3X3X7/16	5X3X1/4	2-1/8 ϕ	3/4" ϕ	2-1/2X 2-1/2X1/4	1"	7	9	60"	50"	9"	4"
66"	3X3X7/16	5X3X1/4	2-1/8 ϕ	3/4" ϕ	2-1/2X 2-1/2X1/4	1"	8	10	66"	56"	11"	6"
72"	4X4X5/8	5X3X1/4	2-3/16 ϕ	1" ϕ	3X3X3/8	1-1/4"	9	11	73"	62"	15"	7"
78"	4X4X5/8	5X3X1/4	2-3/16 ϕ	1" ϕ	3X3X3/8	1-1/4"	10	11	79"	68"	17"	9"
84"	4X4X5/8	5X3X1/4	2-3/16 ϕ	1" ϕ	3X3X3/8	1-1/4"	11	13	86"	74"	21"	10"
90"	4X4X5/8	5X3X1/4	2-3/16 ϕ	1" ϕ	3X3X3/8	1-1/4"	12	13	92"	80"	23"	12"
96"	4X4X5/8	5X3X1/4	2-3/16 ϕ	1" ϕ	3X3X3/8	1-1/4"	12	14	98"	86"	29"	12"

*NOTE: Adjust these values for skewed conduits. Provide 5" maximum opening at each side and between bars.

DETAIL NO. **2562-2**
City of Scottsdale
Standard Details

APPROVED BY: _____

BARRIER SPECIFICATIONS SCHEDULE

DETAIL NO. **2562-2**

MINIMUM TREE SIZE REQUIREMENTS

Name	Size	Height	Width	Caliper	Name	Size	Height	Width	Caliper	Name	Size	Height	Width	Caliper	Name	Size	Height	Width	Caliper					
ACACIA					ACACIA (Cont.)					ARGENTINE MESQUITE	15	5	3	0.75	VELVET ARIZONA (M)	15	5.5	3	0.5	SONORAN	15	6	2	0.75
BLUE LEAF WATTLE	15	6	2	0.75	WEeping	15	5	2	0.75	(M) (PROSOPIS ALBA)	24	8	5	1.25	(PROSOPIS VELUNTINA)	24	7	4	1	(CERCIDIUM PRAECOX)	24	7	4	1.5
(ACACIA SALIGNA)	24	8	4	1.5	(ACACIA PENDULA)	24	6.5	3	1.25		30	9	7	1.5		30	9	6	1.5		30	8	6	2
	30	10	5	2		30	9	5	2		36	11	9	2		36	10	8	2		36	10	8	2.5
	36	12	6	2.5		36	11	6	2.5		42	13	11	2.5		42	12	10	2.5		42	11	10	3
BERLANDIERI GUAJILLO	15	4	2	0.5	WILLOW	15	6	2	0.75		48	15	13	3		48	14	12	3		48	12	12	3.5
(M) (ACACIA BERLANDIERI)	24	5	4	1	AUSTRALIAN WILLOW	24	8	4	1.5	MESQUITE (Cont.)					PALOVERDE					SONORAN (M)	15	5	2	0.5
	30	7	5	1.5	(ACACIA SALICINA)	30	10	5	2	CHILEAN MESQUITE	15	6	2	0.75	BLUE PALO VERDE	15	6	2	0.75	(CERCIDIUM PRAECOX)	24	7	4	1
	36	9	6	2		36	14	6	2.5	(PROSOPIS CHILENSIS)	24	8	4	1.5	(CERCIDIUM FLORIDUM)	24	7.5	4	1.5		30	8	6	1.5
MULGA	15	5	2	0.75	IRONWOOD						30	9	6	2		30	9	7	2		36	10	8	2
(ACACIA ANEURA)	24	7	4	1.5	DESERT IRONWOOD	15	3	2	0.5		36	10	8	2.5		36	10	8	2.5		42	11	10	2.5
	30	9	6	2	(OLNEYA TESOTA)	24	6	3	1.25		42	12	10	3		42	12	9	3		48	12	12	3
	36	10	8	2.5		30	8	6	2	CHILEAN MESQUITE (M)	15	5	3	0.5	BLUE PALO VERDE (M)	15	5	3	0.5	OTHER TREES				
SHOESTRING	15	7	2.5	0.75		36	10	8	2.5	(PROSOPIS CHILENSIS)	24	8	5	1	(CERCIDIUM FLORIDUM)	24	7	4	1	AFRICAN SUMAC	15	7	2	0.75
(ACACIA STENOPHYLLA)	24	9	4	1.5		42	11	9	3		30	9	7	1.5		30	8	6	1.5	(RHUS LANCEA)	24	9	4	1.25
	30	11	5	2		48	12	10	3.5		36	10	9	2		36	10	8	2		30	11	6	2
	36	13	6	2.5	DESERT IRONWOOD (M)	15	3	2	0.5		42	12	11	2.5		42	12	9	2.5		36	12	8	2.5
	42	15	7	3	(OLNEYA TESOTA)	24	6	3	1.25		48	14	13	3		48	14	11	3		42	14	8	3.5
	48	17	8	4		30	8	6	2	HONEY MESQUITE (M)	15	6	2	0.75	LITTLE LEAF FOOTHILLS	15	4	2	0.5	AFRICAN SUMAC (M)	15	5	3	0.75
SHOESTRING (M)	15	7	2.5	0.5		36	10	8	2.5	(PROSOPIS - GLANDULOSA)	24	8	4	1.5	(CERCIDIUM - MICROPHYLLUM)	24	6	3	1	(RHUS LANCEA)	24	8	4.5	1
(ACACIA STENOPHYLLA)	24	9	4	1		42	11	9	3		30	9	6	2		30	7	5	1.5		30	9	7	1.5
	36	13	6	2		48	12	10	3.5		36	10	8	2.5		36	8	6	2		36	11	8	2
SWEET	15	6	2.5	0.75	MESQUITE						42	12	10	3	LITTLE LEAF FOOTHILLS	15	4	3	0.5		42	13	9	2.5
(ACACIA SMALLII)	24	8	4	1.5	ARGENTINE MESQUITE	15	6.5	2	0.75		48	14	12	3.5	(M) (CERCIDIUM - MICROPHYLLUM M)	24	5	4	1		48	16	10	3
	30	9	6	2	(PROSOPIS ALBA)	24	8	4	1.5	SCREW BEAN (M)	15	5.5	3	0.5		30	6	5	1.5	ALEPPO	15	6	3	0.75
	36	10	8	2.5		30	9	6	2	(PROSOPIS - PUBESCENS)	24	8	4	1		36	8	7	2	(PINUS HALEPENSIS)	24	9	4	2
	42	12	10	3		36	11	8	2.5		30	9	6	1.5							30	11	6	3
	48	14	12	3.5		42	13	10	3		42	12	10	3							36	14	7	3.5
SWEET (M)	15	5	3	0.5		48	15	12	3.5		48	14	12	3.5							42	16	9	4
(ACACIA SMALLII)	24	8	5	1																	48	18	10	4.5
	30	9	7	1.5																				
	36	10	9	2																				
	42	12	10	2.5																				
	48	14	12	3																				
					See General Notes																			
					Page 3																			

DETAIL NO. 2600-1	City of Scottsdale Standard Details	APPROVED BY: _____	MINIMUM TREE SIZE REQUIREMENTS	DETAIL NO. 2600-1
-----------------------------	---	-----------------------	---------------------------------------	-----------------------------

MINIMUM TREE SIZE REQUIREMENTS

Name	Size	Height	Width	Caliper	Name	Size	Height	Width	Caliper	Name	Size	Height	Width	Caliper	Name	Size	Height	Width	Caliper	Name	Size	Height	Width	Caliper
ARIZONA ASH (FRAXINUS VELUTINA)	15	8	2	1	Canary Island Pine (Pinus Canariensis)	15	6	2	0.75	COOLIBAH (EUCALYPTUS - MICROTHECA)	15	7	3	0.75	FEATHER BUSH FERN OF THE DESERT (LYSILOMA THORNERI)	15	5	3	0.75	JACARANDA (JACARANDA ACUTIFOLIA)	15	8	2	0.75
	24	10	4	1.5		24	9	4	2		24	10	4	1.5		24	6.5	4	1.25		24	9	4	1.5
	30	12	5	2		30	13	5	3.5		30	12	5	2		30	7	6.5	2		30	12	5	2.5
	36	14	8	2.5		36	17	5	4		36	15	6	2.5		36	8	6	2.5		36	14	8	3
	42	15	9	3		42	18	6	4.5		42	14	9	4		42	4	3	0.75		42	16	8	3.5
ARIZONA SYCAMORE (PLATANUS WRIGHTII)	15	7	2	1	CAROB (CERATONIA SILQUA)	15	8	2	0.75	CORK OAK (QUERCUS SUBER)	15	4	2	0.75	FEATHER BUSH FERN OF THE DESERT(M) (LYSILOMA THORNERI)	15	4	3	0.75	JACARANDA (M) (JACARANDA- ACUTIFOLIA)	15	5.5	3	0.5
	24	9	4	1.5		24	9	4	1.5		24	6.5	3	1.5		24	7	7	1.5		24	8	5	0.75
	30	13	6	2.5		30	10	5	2		30	9	4.5	2.5		30	7	7	1.5		30	10	6	1.5
	36	16	8	3.5		30	10	5	2		36	12	6	3.5		36	8	8	2		36	12	7	2
ARIZONA SYCAMORE(M) (PLATANUS WRIGHTII)	15	6	3	0.5	CHASTE TREE (VITEX ANGUS-CASTUS)	15	5	3	0.75	CORRAL GUM (EUCALYPTUS TORQUATA)	15	6	2.5	0.75	FICUS (FICUS NITIDA)	15	8	2	0.75	LEMON BOTTLE BRUSH (CALLISTEMON CITRINUS)	15	8	2	0.75
	24	8	4	1		24	6	4	1.25		24	8	3.5	1.25		24	9	4	1.25		24	9	4	1.25
	30	12	7	2		30	7	5	2		30	6	2	0.75		30	5.5	3	0.5		30	10	5	2
	36	15	9	3		36	8	6	2.5		36	8	6	2.5		36	12	8	2.5		36	12	6	2.75
AUSTRALIAN WILLOW WILGA (GEIJERA PARVIFLORA)	15	5	3	0.75	CHINESE EVERGREEN ELM (ULMUS PARVIFOLIA)	15	7	2	0.75	DESERT WILLOW (CHILOPSIS LINEARIS)	15	6	2	0.75	FICUS (FICUS NITIDA M)	15	8	4	1	MEDITERANEAN FAN PALM (CHAMAEROPS HUMULIS)	15	2	2	N/A
	24	8	4	1.25		24	8	3	1.25		24	7	4	1.25		24	10	6	2		24	3	3	N/A
	30	10	5	2		30	12	6	2		30	9	6	1.75		30	10	6	2		30	4	4	N/A
BOTTLE TREE (BRACHYCHITON - POPULNEUS)	15	6	2	1.5	CHINESE PISTACHE (PISTACIA CHINENSIS)	15	7	2	0.75	DESERT WILLOW (M) (CHILOPSIS LINEARIS)	15	5	3	0.75	FLOODED GUM (EUCALYPTUS RUDIS)	15	8	3	1	MESCAL BEAN TEXAS MOUNTAIN LAUREL (SOPHORA - SECUNDIFLORA)	15	3	1	0.75
	24	9	4	2.5		24	9	4	1.5		24	7	5	1		24	9	4	1.25		24	4	2	1
	30	12	5	4		30	10	5	2.5		30	9	6	1.5		30	11	8	2		30	5	3	1.75
	36	15	6	5		36	12	6	3.5		36	10	8	2		36	13	10	2.5		36	6	4	2
	42	17	8	6		42	16	9	3.5		42	14	9	4		42	15	11	3		42	15	3	0.75
BRAZILIAN PEPPER (SCHINUS - TEREBINTHIFOLIA)	15	8	2	0.75	CHIR PINE INDIAN LONG LEAF (PINUS ROXBURGHII)	15	5	3	1	ELDARICA (PINUS ELDARICA)	15	6	2	1.5	FLOWERING CHERRY (PRUNUS VARIETIES)	15	6	2.5	0.75	MOUNTAIN LAUREL (M) (SOPHORA - SECUNDIFLORA)	15	3	2	0.75
	24	9	4	1.25		24	9	4	1.5		24	10	4	2		24	9	4	1.5		24	4	3	1
	30	10	5	2.5		30	10	5	2.5		30	13	4	3		30	11	8	2		30	5	4	1.5
	36	12	8	3		36	12	6	3.5		36	15	5	4		36	17	12	3.5		36	6	5	2
CALIFORNIA PEPPER (SCHINUS MOLLE)	15	7	2	0.75	See General Notes Page 3	15	5	3	1	EVERGREEN PEAR (PYRUS KAWAKAMI)	15	7	2	0.75	HONEY LOCUST (GLEDITSIA TRIACANTHOS INERMIS)	15	8	2	0.75	MEXICAN PALO VERDE JERUSALEM (PARKINSONIA ACULEATA)	15	7	3	1
	24	8	4	1.25		24	8	4	2		24	9	4	1.5		24	9	4	1.5		24	9	6	1.5
	30	10	6	2.5		30	11	6	2.5		30	10	6	2		30	10	6	2		30	11	9	2.5
	36	12	8	3		36	15	6.5	3.5		36	12	8	3.5		36	12	8	2.5		36	12	10	3
	42	17	8	4.5		42	17	8	4.5		42	14	10	4		42	14	10	3					
48	20	9	5	48	20	9	5	48	16	12	4.5	48	16	12	3.5									

DETAIL NO. 2600-2	City of Scottsdale Standard Details	APPROVED BY: _____	MINIMUM TREE SIZE REQUIREMENTS	DETAIL NO. 2600-2
-----------------------------	--	-----------------------	---------------------------------------	-----------------------------

MINIMUM TREE SIZE REQUIREMENTS

Name	Size	Height	Width	Caliper	Name	Size	Height	Width	Caliper	Name	Size	Height	Width	Caliper	Name	Size	Height	Width	Caliper					
MODESTO ASH (FRAXINUS V. MODESTO)	15	8	2	1	RAYWOOD ASH CLARET ASH (FRAXINUS O. RAYWOODII)	15	8	4	1	SILK TREE MIMOSA (M) (ALBIZIA JULIBRISSIA)	15	5	3.5	0.5	SILK TREE MIMOSA (ALBIZIA JULIBRISSIN)	15	6	3	0.75					
	24	10	4	1.5		24	10	3	1.5		24	6.5	5	0.75		24	8	4	1.5					
	30	12	6	2		30	12	5	2		30	6	6	1		30	10	6	2					
	36	14	7	2.5		36	14	8	2.5		36	10	8	2.5		36	12	8	3					
	42	16	8	3		42	16	10	3		42	16	10	3		42	10	8	3					
	48	17	10	3.5		48	18	12	4		48	18	12	4		48	11	11	3					
NARROW LEAF GIMLET	15	6	2.5	0.75	RED CAP GUM (EUCALYPTUS- ERYTHROCORYES)	15	6.5	2.4	0.75	SILVER DOLLAR GUM (EUCALYPTUS- POLYANTHEMOS)	15	7	3	0.75	TEXAS EBONY (M) (PITHECELLBIUM- FLEXICAULE)	15	4	2	0.5					
SWAMP MALLET (EUCALYPTUS - SPATHULATA)	24	8	3	1		24	8	4	1.25		24	10	4	1.5		24	6	4	1					
OLEANDER (NERIUM OLEANDER)	15	7	2	0.75	RED GUM (EUCALYPTUS- CAMALDULENSIS)	15	8	3	1	SISSOO (DALBERGIA SISSOO)	15	7	3	0.75	WEeping BOTTLE BRUSH (CALLISTEMON VIMINALIS)	15	8	2	0.75					
	24	9	4	1.25		24	10	4	1.75		24	10	4	1.25		24	10	3.5	1.5					
	30	10	5	2		30	10	4	1.5		30	12	7	2.5		30	12	5	2					
	36	12	6	2.5		36	15	10	3		36	15	10	3		36	14	7	2.5					
OLIVE TREE (OLEA EUROPAEA)	15	5	3	0.5	RED IRON BARK (EUCALYPTUS - SIDEROXYLON)	15	8	3	0.75	SOUTHERN LIVE OAK HERITAGE (QUERCUS VIRGINIANA)	15	6	2	0.75	WEeping WILLOW (SALIX BABYLONICA)	15	8	2	1					
	24	8	5.5	1.5		24	10	4	1.75		24	9	4	1.25		24	10	4	1.5					
	30	11	9	2		30	12	5	2		30	11	6.5	2		30	12	6	2.5					
	36	12	10	3		36	14	8	2.5		36	13	8	2.75		36	14	8	4					
	42	14	12	3.5		42	15	9	3.5		42	15	10	3.5		42	10	4	1.5					
	48	16	14	4		48	16	10	4		48	17	12	4.5		48	12	6	2.5					
ORCHID TREE (BAUHINIA)	15	8	2	0.75	SHAMEL EVERGREEN (FRAXINUS UHDEI)	15	8	2	1	TEXAS EBONY (PITHECELLBIUM- FLEXICAULE)	15	5	2	0.75	WHITE IRON BARK (EUCALYPTUS - LEUCOXYLON)	15	6.5	2.5	0.75					
	24	9	4	1.25		24	10	4	1.5		24	6	3	1.5		24	8	3.5	1.25					
	30	11	6	2		30	12	5	2.5		30	7	4	2		30	8	3.5	1.25					
	36	13	7	2.5		36	14	8	3		36	9	6	2.5		36	9	6	2.5					
ORNAMENTAL PEAR (PYRUS CALLERYANA)	15	7	2	1	SILK OAK (GREVILLEA ROBUSTA)	15	8	3	1	YELLOW OLEANDER (THEVETIA PERUVIANA)	15	6	2	0.5										
	24	10	3.5	1.5		24	10	4	1.5		15	4	3.5	0.5										
	30	12	6	2.5		30	12	5	2.5		24	6	5	0.75										
	36	14	8	3		36	14	8	3															
	42	16	10	3.5		42	15	9	3.5															
	48	18	12	4		48	16	10	4															

GENERAL NOTES:

1. All trees shall be guaranteed for one year from the date of acceptance
2. "M" designates a multitrunk tree. A multitrunk tree is a tree with more than one main trunk.
3. Caliper is measured at 12" above the ground for trees with caliper greater than 4". For multitrunk trees, and trees with caliper of less than 4", the caliper is measured 6" above the ground.
4. Size is listed as the box size in inches except for those trees in 15 gallon containers.

DETAIL NO. 2600-3	City of Scottsdale Standard Details	APPROVED BY: _____	MINIMUM TREE SIZE REQUIREMENTS	DETAIL NO. 2600-3
------------------------------------	--	--------------------	---------------------------------------	------------------------------------

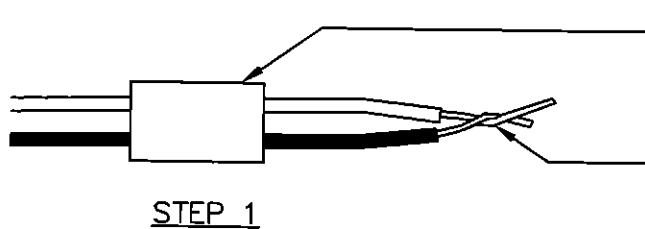

SLIP BASE SOCKET OVER
END OF WIRES

STEP 1

STRIP WIRES APPROX. 5/8" FROM
ENDS - TWIST ENDS TOGETHER

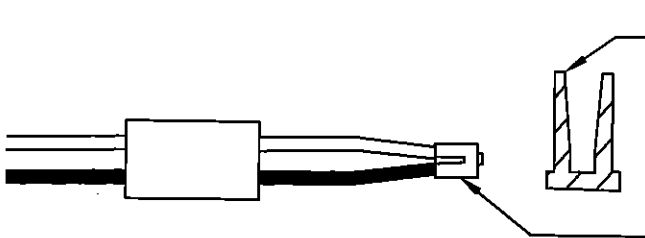

APPLY SEALER TO OUTSIDE OF SEALING
PLUG - FILL CAVITY WITH SEALER

STEP 2

PUT CRIMP SLEEVE OVER WIRE
ENDS - CRIMP SLEEVE AND CUT
OFF EXCESS WIRE

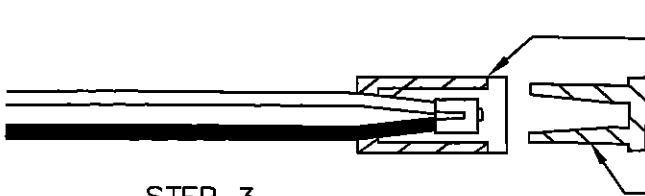

PULL BASE SOCKET OVER WIRE
END AS FAR AS POSSIBLE

STEP 3

PUSH SEALING PLUG INTO
BASE SOCKET

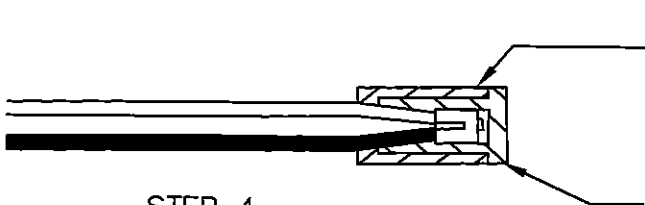

PUSH WIRES TO END OF BASE
SOCKET TO ASSURE COMPLETE
SEALING OF CONNECTION

STEP 4

DRI-SPLICE TYPE WIRE
CONNECTOR

NOTE:

1. FOR WIRE SIZES NO. 14, 12 AND 10, ALL CONNECTIONS IN VALVE BOXES ONLY.

DETAIL NO.
2610

City of Scottsdale
Standard Details

TYPICAL WIRE CONNECTION

DETAIL NO.
2610

REVISED 7/29/96

Prune Tree At Time Of Stake Removal.

(2) 2" Diameter x 10' Long Lodgepole Pine Tree Stakes. Bury 3' In Ground And Cut Off Stake 12" Above Vinyl Tie. Stakes Shall Remain In Place For 2 Years Unless Removal Is Approved By Maintenance Director.

Mulch To A Depth Of 1/2", 5' In Diameter. Keep Mulch 6" Away From Trunk.

Backfill With Native Soil. (No Rocks Greater Than 1") Apply Fertilizer To Surface Away From Trunk Per Specifications.

Scarify One Side Of Root Ball Prior To Planting

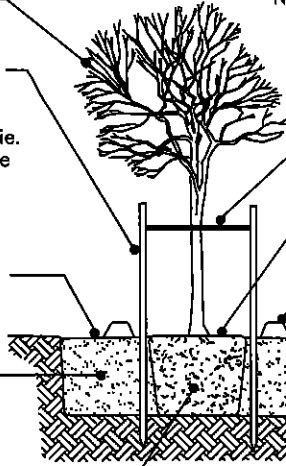

Tree Planting and Staking ≤36" Box Or 2" Caliper

Note: Sufficient clearance shall be maintained between trees and utility facilities so as to not hinder use of these facilities.

Note: Sufficient clearance shall be maintained between shrubs and utility facilities so as to not hinder use of these facilities.

Mulch Soil To A Depth Of 2", 2' In Diameter For 1 Gal. Shrubs, 4' In Diameter For 5 Gal. Shrubs, Keep Mulch 4" Away From Plant Base.

Backfill With Native Soil. Apply Fertilizer To Surface Away From Trunk Per Specifications.

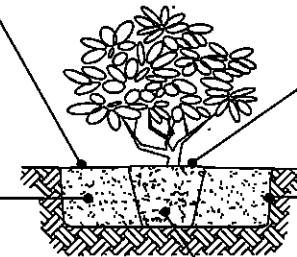

Shrub Planting

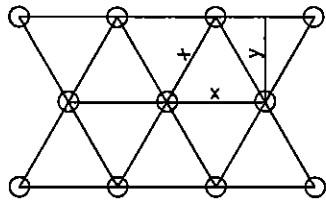

All Groundcovers To Be Planted On Center (See Plant Legend) In A Triangular Pattern.

X = O.C. Dimension As Noted On Plan
Y = 0.86 Of Dimension "X"

Mulch Soil To A Depth Of 2", 1' In Diameter. Keep Mulch 2" Away From Plant Base.

Prepare Soil Per Specifications And Rototill To A Depth Of 6" Prior To Any Sprinkler Work.

Backfill With Native Soil. Apply Fertilizer To Surface Away From Trunk Per Specifications.

Groundcovers

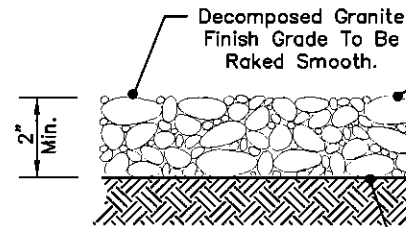

Provide Final Application Of Weed Control Upon Final Raking.

Fine Graded Subgrade

Apply Pre-Emergent Herbicide As Per Manufacturers Recommendations. (Surflan Or Equal Approved By City Of Scottsdale)

Decomposed Granite

DETAIL NO.
2620-1

**City of Scottsdale
Standard Details**

APPROVED

LANDSCAPE DETAILS

DETAIL NO.
2620-1

REVISED 1/5/00

Garden Hose Reinforced With Wire (Metal).

Use Golf Sand Or 1/4" Minus Decomposed Granite To Backfill Planting Hole. Backfill 1/2 Of Pit, Then Compact.

Root Prune All Shredded Or Damaged Roots And Dust Entire Root Structure With Wettable Sulphur (1.5 Min.) And Streptomycin Spray At Planting Site. Root Ball Minimum Size Shall Be 24" With A Minimum Root Length Of 6" On All Sides.

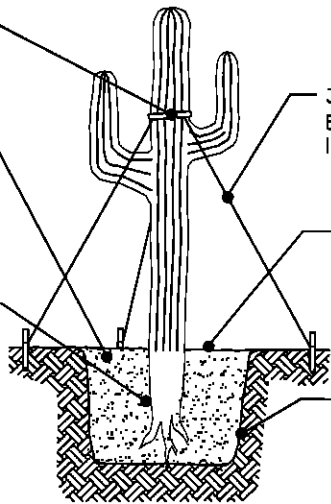

3 Tree Braces, Spaced Equally. Braces To Remain In Place For One Year Min.

6 - 1 Gallon Emitters In 'Hula Hoop' Distribution, Run Once A Month 24 To 48 Hours For One Year.

Planting Hole Width Shall Be 3 Times Diameter Of Roots And No Deeper Than The Extension Of The Roots.

Saguaro Planting Type A

NOTES:

1. Optimum transplanting season is October thru November.
2. Maintain original plant orientation. The original "North" orientation shall be marked on a rib at a height of 5' above ground level.
3. Water thoroughly at the time of transplanting to remove air pockets and assure proper compaction. Backfill shall be free of injurious rocks and debris.
4. Do not water for 3 weeks after planting.
5. Plant in areas safe from present and future construction activities.
6. Transplant to original depth of bury.

NOTE: Water weekly through the summer.

Plant At Depth Which Plant Was Grown.

Planting Mix To Be 1/3 Golf Sand And 2/3 Specified Soil. Pack The Backfill Mix, Do Not Use Water To Settle Backfill Mix.

Planting Hole Width Shall Be 3 Times Diameter Of Roots And No Deeper Than The Extension Of The Roots.

Use 6" to 8" Rocks To Anchor Roots.

Root Prune All Shredded Or Damaged Roots And Dust Entire Root Structure With Wettable Sulphur (1.5 min.) At Planting Site.

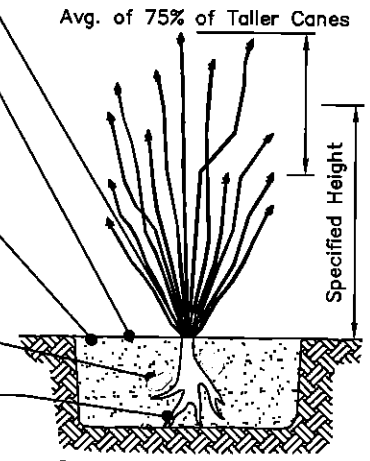

Ocotillo Planting

(3) 2"x 6" Braces, Spaced Equally And Nailed To Wooden Stakes In The Ground. Braces To Remain In Place For One Year Min.

Use Golf Sand Or 1/4" Minus Decomposed Granite To Backfill Planting Hole. Backfill 1/2 Of Pit, Then Compact.

Root Prune All Shredded Or Damaged Roots And Dust Entire Root Structure With Wettable Sulphur (1.5 Min.) And Streptomycin Spray At Planting Site. Root Ball Minimum Size Shall Be 24" With A Minimum Root Length Of 6" On All Sides.

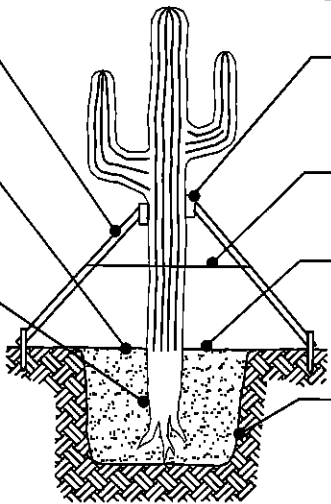

4"x 8"- Dense Foam And Carpet Padded, 8' Above Natural Grade And Nailed To Brace.

Steel Band Fastened With 2 Large Staples Per Brace.

6 - 1 Gallon Emitters In 'Hula Hoop' Distribution, Run Once A Month 24 To 48 Hours For One Year.

Planting Hole Width Shall Be 3 Times Diameter Of Roots And No Deeper Than The Extension Of The Roots.

Saguaro Planting Type B

NOTES:

1. Optimum transplanting season is October thru November.
2. Maintain original plant orientation. The original "North" orientation shall be marked on a rib at a height of 5' above ground level.
3. Water thoroughly at the time of transplanting to remove air pockets and assure proper compaction. Backfill shall be free of injurious rocks and debris.
4. Do not water for 3 weeks after planting.
5. Plant in areas safe from present and future construction activities.
6. Transplant to original depth of bury.

NOTES: Water weekly through the summer. Maintain original growing orientation.

Plant At Depth Which Plant Was Grown.

Planting Mix To Be 1/3 Golf Sand And 2/3 Specified Soil. Pack The Backfill Mix, Do Not Use Water To Settle Backfill Mix.

Planting Hole Width Shall Be 3 Times Diameter Of Roots And No Deeper Than The Extension Of The Roots.

Use 6" to 8" Rocks To Anchor Roots.

Root Prune All Shredded Or Damaged Roots And Dust Entire Root Structure With Wettable Sulphur (1.5 min.) At Planting Site.

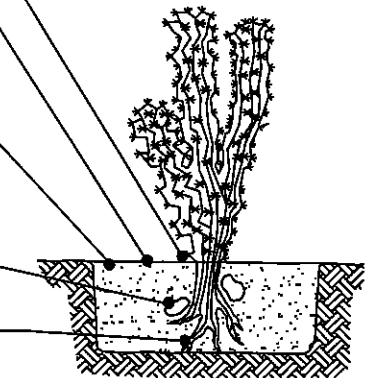

Cactus Planting

DETAIL NO.

2620-2



City of Scottsdale
Standard Details

LANDSCAPE DETAILS

DETAIL NO.

2620-2

REVISED 1/5/00

Staking Required For Trees In 36" Box Or Less Or With A Caliper Of Less Than 2". (2) 2" Diameter x 10' Long Lodgepole Pine Tree Stakes. Bury 3' In Ground And Cut Off Stake 12" Above Vinyl Tie. Stakes Shall Remain In Place For 2 Years Unless Removal Is Approved By Maintenance Director.

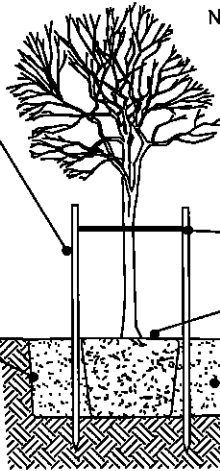

- Notes: 1. Sufficient clearance shall be maintained between trees and utility facilities so as to not hinder use of these facilities.
2. Plant pit basins within sloped planting areas shall be constructed with a max. 2:1 slope. Provide smooth transition to surrounding finish grade.

Vinyl Tie, 1" (Min.) In Width

Set Top Of Root Ball At Soil Surface.

Backfill With Native Soil. (No Rocks Greater Than 3") Backfill 3/4 The depth Of Rootball Before Removing Box Side Panels. Compact Backfill As Needed To Prevent Breaking Rootball.

Planting Hole Shall Be 2 Times Diameter Of Root Ball And No Deeper. Scarify Sides And Bottom Of Planting Hole

(LEFT BLANK)

Salvaged Tree Planting

Thin Top 6-8 Fronds, Tie With Natural Fiber Twine. (Remove Ties Prior To Buckling 60-90 Days).

Plant At Depth Which Plant Was Grown. Adjusting Root Ball Depth To Align Finished Height Will Not Be Allowed.

100% Golf Sand Backfill. Settle Backfill With Water, Do Not Pack Backfill.

Planting Hole Width Shall Be 3 Times Diameter Of Roots And No Deeper Than The Extension Of The Roots.

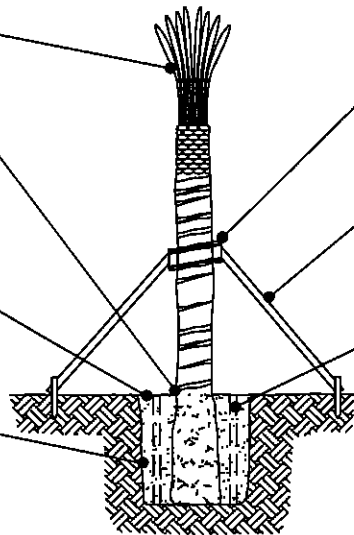

2"x 4" Blocking Nailed To Brace. Tie To Trunk With 1" (Min.) Vinyl Tie.

(3) 2"x 6" Braces, Spaced Equally And Nailed To Wooden Stakes In The Ground.

4" Perforated PVC, 2 Per Tree. Wrap PVC With Soil Screen Fabric.

(LEFT BLANK)

Palm Planting and Bracing Detail

DETAIL NO.

2620-3

City of Scottsdale
Standard Details

LANDSCAPE DETAILS

DETAIL NO.

2620-3

REVISED: 4/25/02

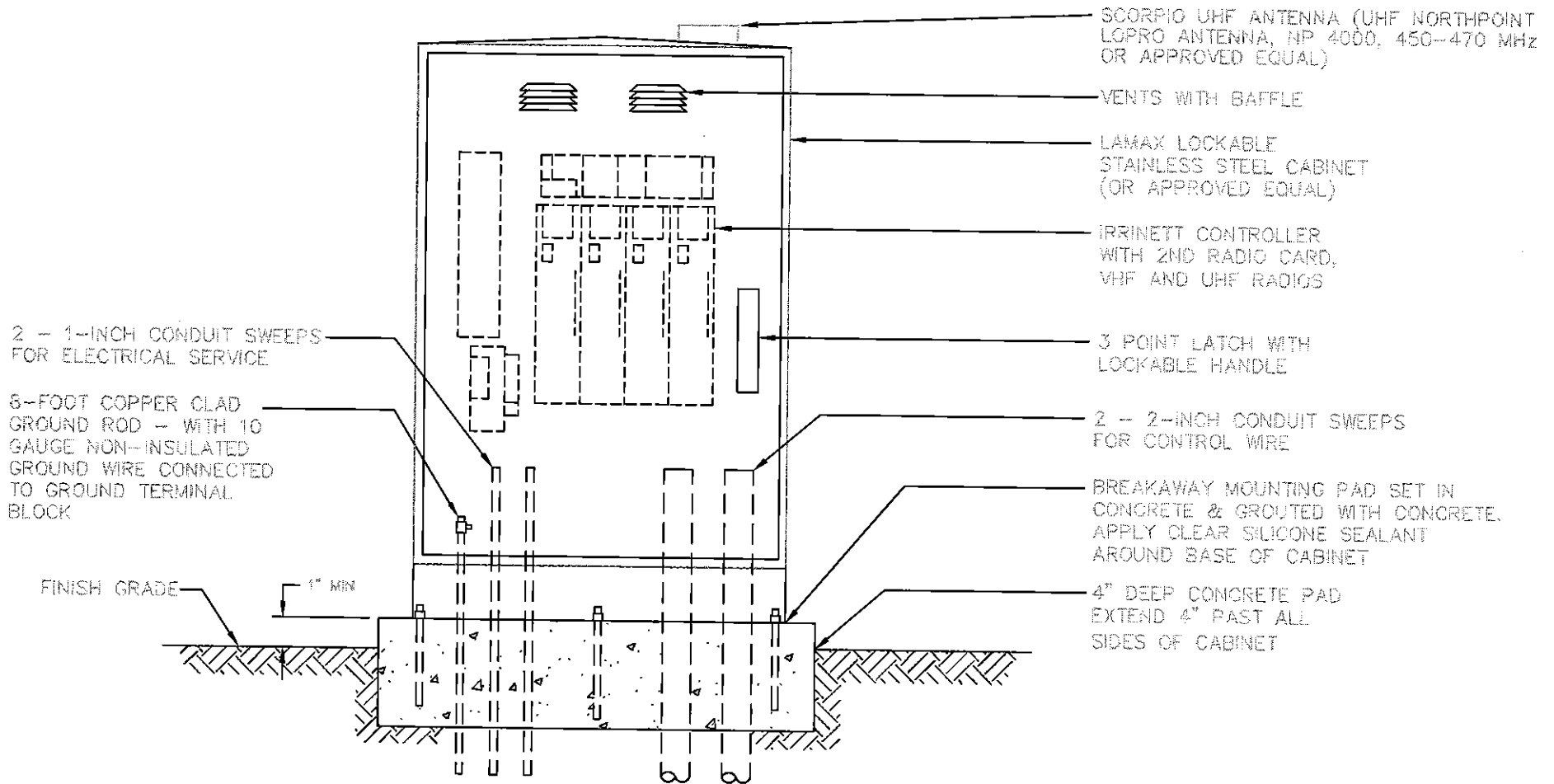

NOTES:

1. POWER SOURCE FOR CONTROLLER TO BE HARD WIRED FROM CIRCUIT BREAKER MOUNTED INSIDE CABINET TO CONTROLLER.
2. LOCATION OF POWER SOURCE TO BE NOTED ON CIRCUIT BREAKER PANEL.
3. PROGRAMMING KEYPAD TO BE SUPPLIED WITH CONTROLLER.
4. CONTROLLER TO BE LOCATED IN AREA WITH POSITIVE DRAINAGE.
5. INSTALL ONLY ONE CONTROL VALVE WIRE PER CONTROLLER OUTPUT.
6. VHF AND UHF RADIOS TO BE TUNED TO C.O.S. FREQUENCIES. CONTACT IRRINET DEPARTMENT FOR INFORMATION (480-312-2189)

DETAIL NO. 2631
 City of Scottsdale
 Standard Details

IRRINET PEDESTAL MOUNTED CONTROLLER

DETAIL NO. 2631

SCORPIO UHF ANTENNA (UHF NORTHPOINT
LOPRO ANTENNA, NP 4000, 450-470 MHz
OR APPROVED EQUAL)

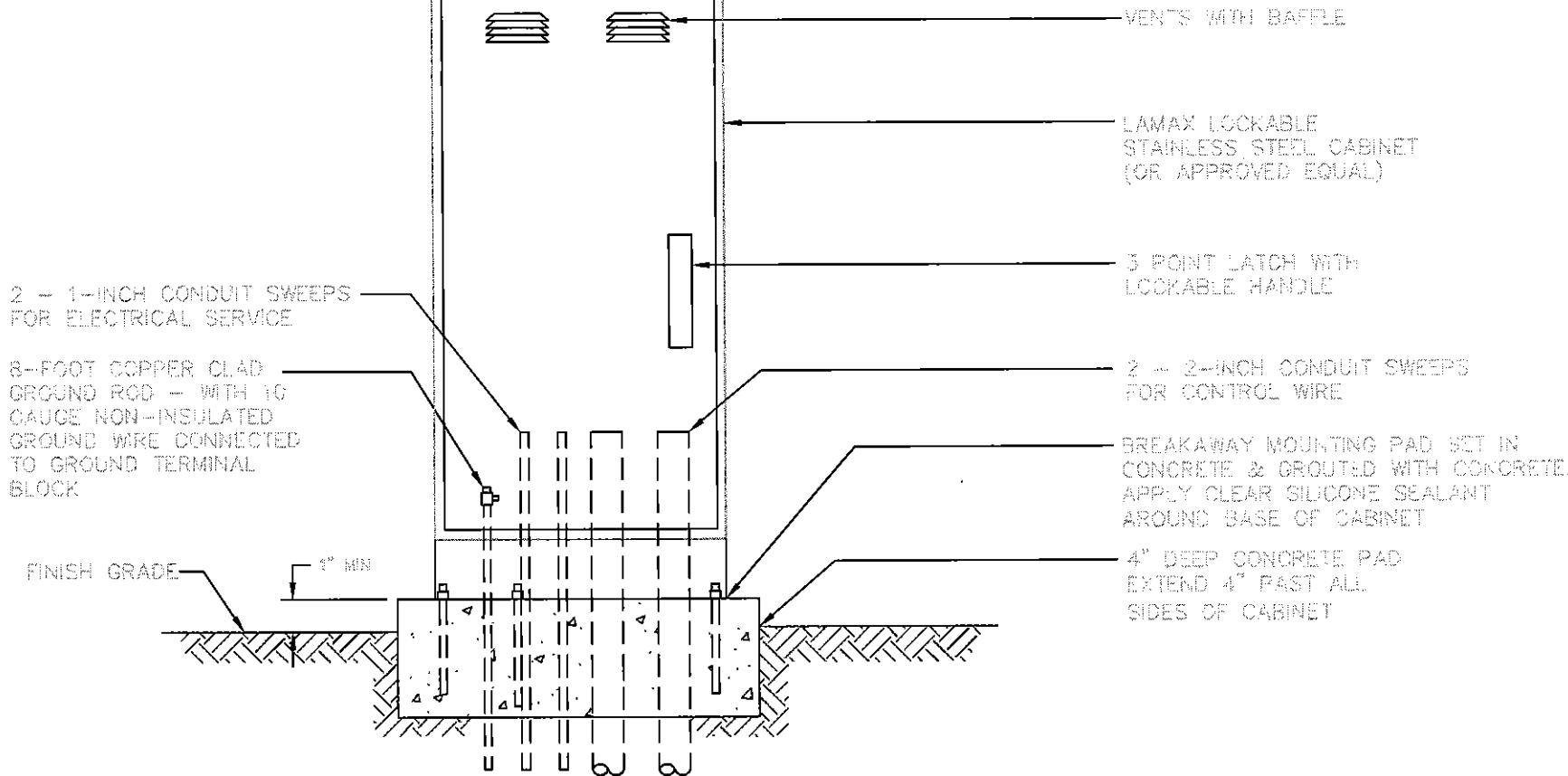

2 - 1-INCH CONDUIT SWEEPS
FOR ELECTRICAL SERVICE

8-FOOT COPPER CLAD
GROUND ROD - WITH 10
GAUGE NON-INSULATED
GROUND WIRE CONNECTED
TO GROUND TERMINAL
BLOCK

FINISH GRADE

1" MIN

VENTS WITH BAFFLE

LAMAX LOCKABLE
STAINLESS STEEL CABINET
(OR APPROVED EQUAL)

3 POINT LATCH WITH
LOCKABLE HANDLE

2 - 2-INCH CONDUIT SWEEPS
FOR CONTROL WIRE

BREAKAWAY MOUNTING PAD SET IN
CONCRETE & GROUTED WITH CONCRETE.
APPLY CLEAR SILICONE SEALANT
AROUND BASE OF CABINET

4" DEEP CONCRETE PAD
EXTEND 4" PAST ALL
SIDES OF CABINET

- NOTES:
1. POWER SOURCE FOR CONTROLLER TO BE HARD WIRED FROM CIRCUIT BREAKER MOUNTED INSIDE CABINET TO CONTROLLER.
 2. LOCATION OF POWER SOURCE TO BE NOTED ON CIRCUIT BREAKER PANEL.
 3. REMOTE CONTROL VALVES FOR D.C. SCORPIO APPLICATIONS MUST HAVE D.C. LATCHING SOLENOIDS AND APPROVED SOLAR PANEL FOR POWER SOURCE.
 4. JSLM NARROW BAND RADIO # 2845 G TO BE INSTALLED WITH SCORPIO CONTROLLER.
 5. PROGRAMMING KEYPAD TO BE SUPPLIED WITH CONTROLLER.
 6. CONTROLLER TO BE LOCATED IN AREA WITH POSITIVE DRAINAGE.
 7. INSTALL ONLY ONE CONTROL VALVE WIRE PER CONTROLLER OUTPUT.
 8. UHF RADIO TO BE TUNED TO C.O.S. FREQUENCIES. CONTACT IRRIGATION DEPARTMENT FOR INFORMATION (480-312-2189)

DETAIL NO. City of Scottsdale
2032 Standard Details

SCORPIO PEDESTAL MOUNTED CONTROLLER

DETAIL NO.
2032

REVISED: 4/25/02

REVISED: 7/15/03

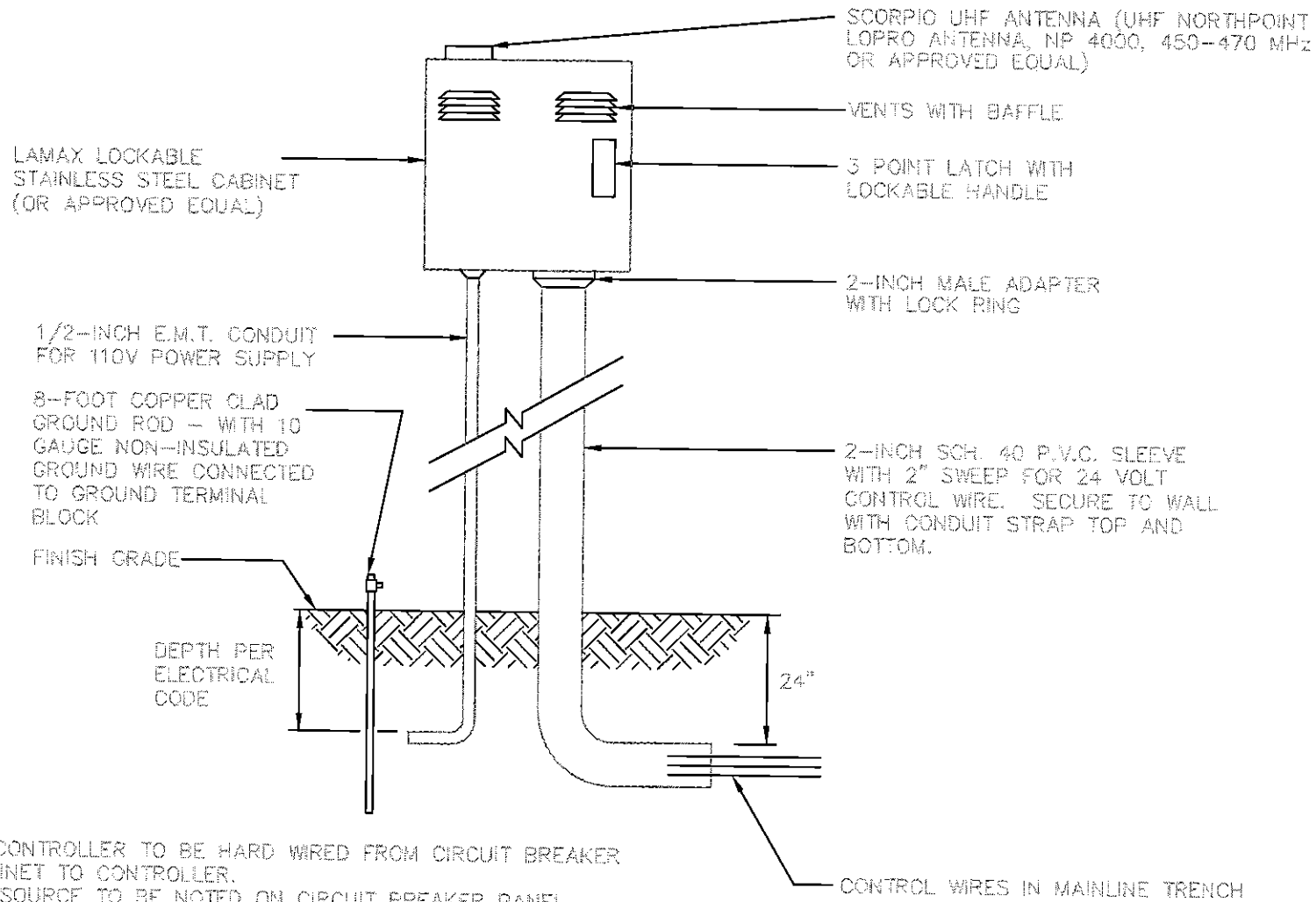

NOTES:

1. POWER SOURCE FOR CONTROLLER TO BE HARD WIRED FROM CIRCUIT BREAKER MOUNTED INSIDE CABINET TO CONTROLLER.
2. LOCATION OF POWER SOURCE TO BE NOTED ON CIRCUIT BREAKER PANEL.
3. REMOTE CONTROL VALVES FOR D.C. SCORPIO APPLICATIONS MUST HAVE D.C. LATCHING SOLENOIDS AND APPROVED SOLAR PANEL FOR POWER SOURCE.
4. JSJM NARROW BAND RADIO #2846 G TO BE INSTALLED WITH SCORPIO CONTROLLER.
5. PROGRAMMING KEYPAD TO BE SUPPLIED WITH CONTROLLER.
6. INSTALL ONLY ONE CONTROL VALVE WIRE PER CONTROLLER OUTPUT.
7. UHF RADIO TO BE TUNED TO C.O.S. FREQUENCIES. CONTACT IRRIGATION DEPARTMENT FOR INFORMATION (480-312-2189)

DETAIL NO. **2633** City of Scottsdale
 Standard Details

SCORPIO WALL MOUNTED CONTROLLER

DETAIL NO. **2633**

REVISION: 4/15/02

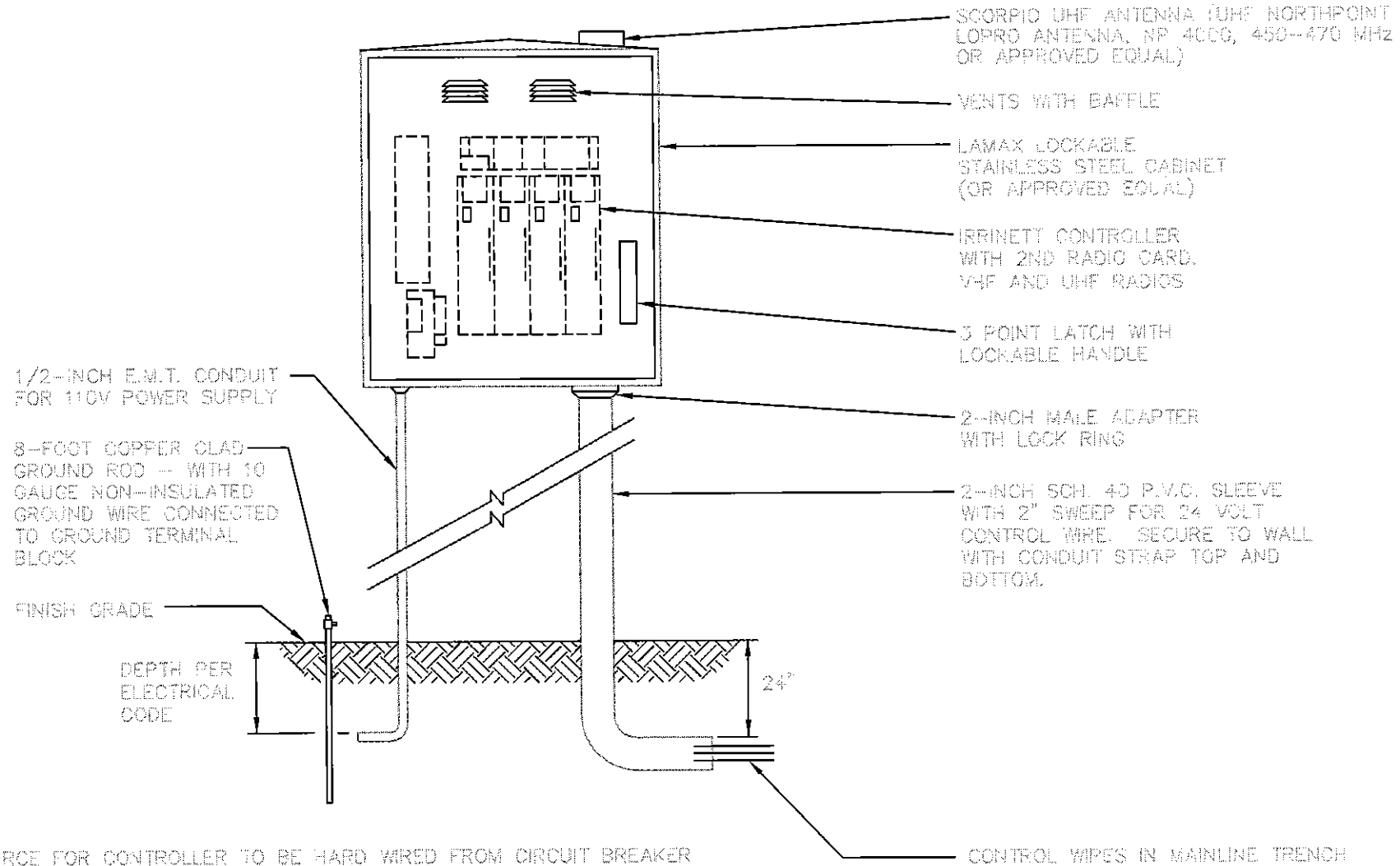

NOTE:

1. POWER SOURCE FOR CONTROLLER TO BE HARD WIRED FROM CIRCUIT BREAKER MOUNTED INSIDE CABINET TO CONTROLLER.
2. LOCATION OF POWER SOURCE TO BE NOTED ON CIRCUIT BREAKER PANEL.
3. PROGRAMMING KEYPAD TO BE SUPPLIED WITH CONTROLLER.
4. INSTALL ONLY ONE CONTROL VALVE WIRE PER CONTROLLER OUTPUT.
5. VHF AND UHF RADIOS TO BE TUNED TO C.O.S. FREQUENCIES. CONTACT IRRIGATION DEPARTMENT FOR INFORMATION (480-312-2189)

IRRINET WALL MOUNTED CONTROLLER

NOTES:

1. INSTALL WIRE OF APPROPRIATE GAUGE, CONNECTORS, SEALANT, AND ADAPTORS PER MANUFACTURERS INSTRUCTIONS.
2. D.C. LATCHING SOLENOIDS ON REMOTE CONTROL VALVES TO BE COMPATIBLE WITH CONTROLLER.
3. MASTER VALVE TO BE INSTALLED AND WIRED TO CONTROLLER. RAINBIRD GB VALVE, SAME SIZE AS MAINLINE INSTALLED PER COS DETAIL #2654 (REMOTE CONTROL VALVE) WITH DC LATCHING SOLENOID COMPATIBLE WITH CONTROLLER.
4. PROGRAMMING/ACCESS KEY TO BE SUPPLIED WITH CONTROLLER.
5. INSTALL MANUFACTURERS STAINLESS STEEL ENCLOSURE FOR CONTROLLER.
6. PROVIDE 12" EXPANSION COIL FOR EACH WIRE SPLICE INSIDE SPLICE BOX WHEN SPLICES ARE REQUIRED BY MANUFACTURER.

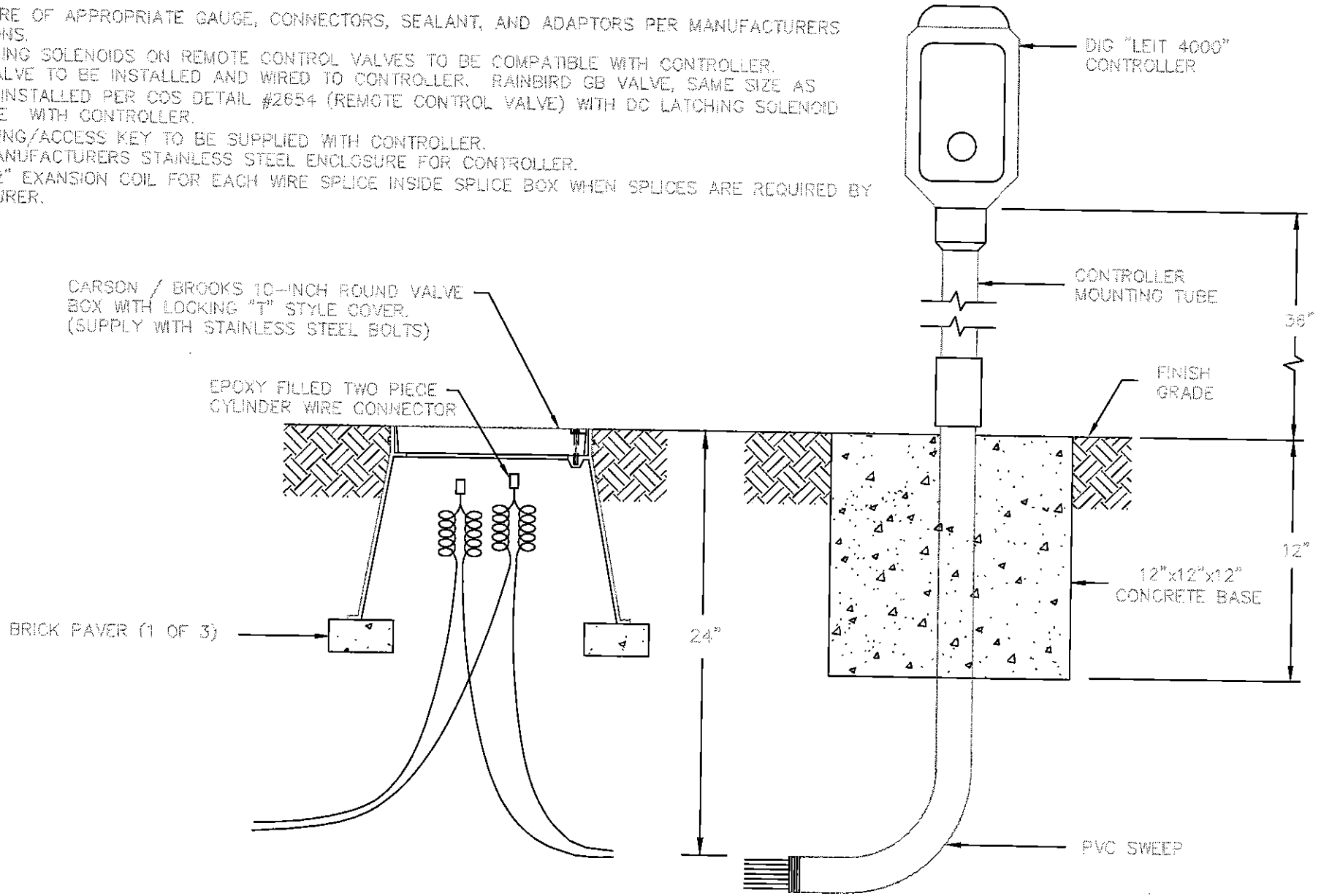

REVISED: 4/25/02

DETAIL NO. 2635-1 City of Scottsdale Standard Details

SOLAR CONTROLLER

DETAIL NO. 2635-1

REVISED 4/26/02

NOTES:

1. INSTALL WIRING OF APPROPRIATE GAUGE, CONNECTORS, SEALANT, AND ADAPTORS PER MANUFACTURERS INSTRUCTIONS.
2. INSTALL CONTROL WIRES, SPLICES, AND MOUNTING COLUMN AS FURNISHED/SPECIFIED BY THE CONTROLLER MANUFACTURER.
3. LABEL ALL WIRES IN CONTROLLER.
4. D.C. LATCHING SOLENOIDS ON REMOTE CONTROL VALVES TO BE COMPATIBLE WITH CONTROLLER.
5. MASTER VALVE TO BE INSTALLED AND WIRED TO CONTROLLER. RAINBIRD GB VALVE, SAME SIZE AS MAINLINE INSTALLED PER COS DETAIL #2654 (REMOTE CONTROL VALVE) WITH DC LATCHING SOLENOID COMPATIBLE WITH CONTROLLER.
6. REFER TO COS DET 2354 FOR ADDITIONAL BACKFLOW PREVENTION DEVICE DETAILS.
7. PROGRAMMING/ACCESS KEY TO BE PROVIDED WITH CONTROLLER.
8. PROVIDE 12" EXANSION COIL FOR EACH WIRE SPLICE INSIDE SPLICE BOX WHEN SPLICES ARE REQUIRED BY MANUFACTURER.

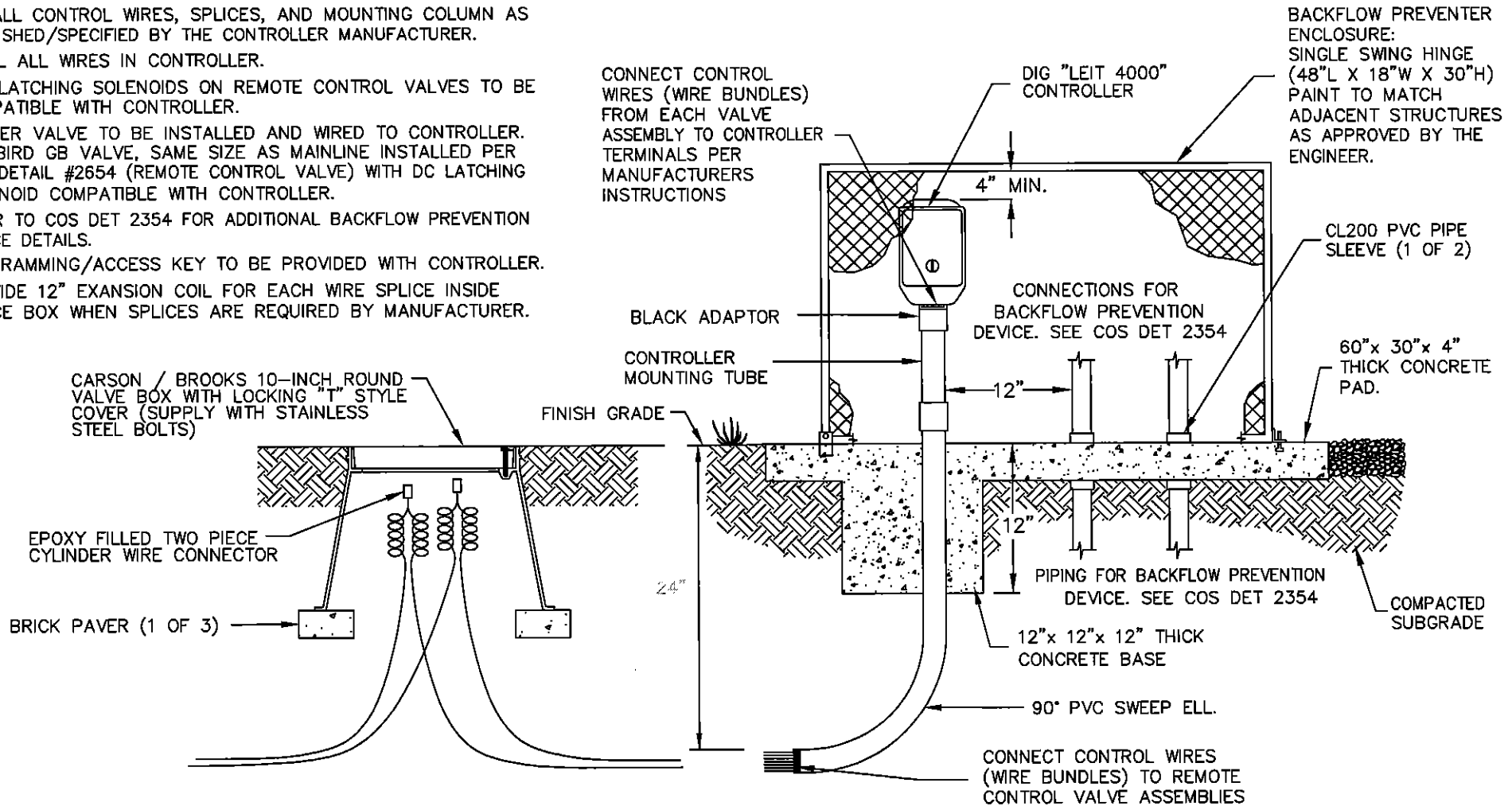

DETAIL NO. **2635-2** City of Scottsdale
Standard Details

SOLAR CONTROLLER AND BACKFLOW PREVENTER ENCLOSURE

DETAIL NO. **2635-2**

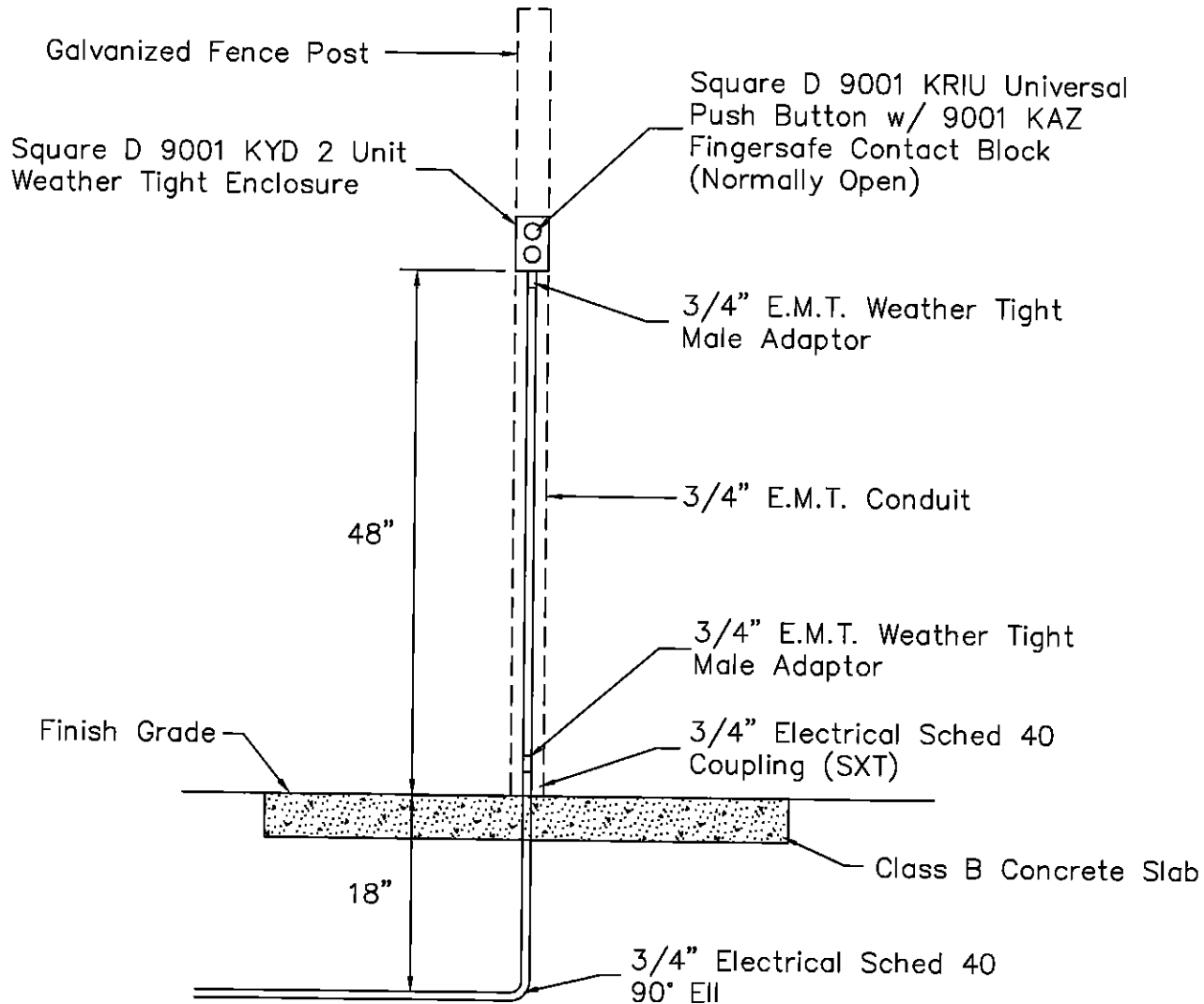

NOTES:

1. Install #14 ga. irrigation control wire.
2. Install one control wire per push button. Control wire to be different color from all other irrigation control wires.
3. Common wire (#12 ga) for push buttons shall be a separate common wire and not part of the irrigation control valve common wire.
4. Push button common wire to have color stripe matching push button control wire. The common wire may be shared by other push buttons.
5. Attach push button enclosure to galvanized post with two self-tapping hex head screws.
6. For other configurations/applications, contact Irrigation Dept 480-312-2189.
7. Label control wires inside enclosure and at controller to differentiate their functionality.

DETAIL NO.
2636

City of Scottsdale
Standard Details

IRRIGATION PUSH BUTTON CONTROL

DETAIL NO.
2636

REVISED: 4/25/02

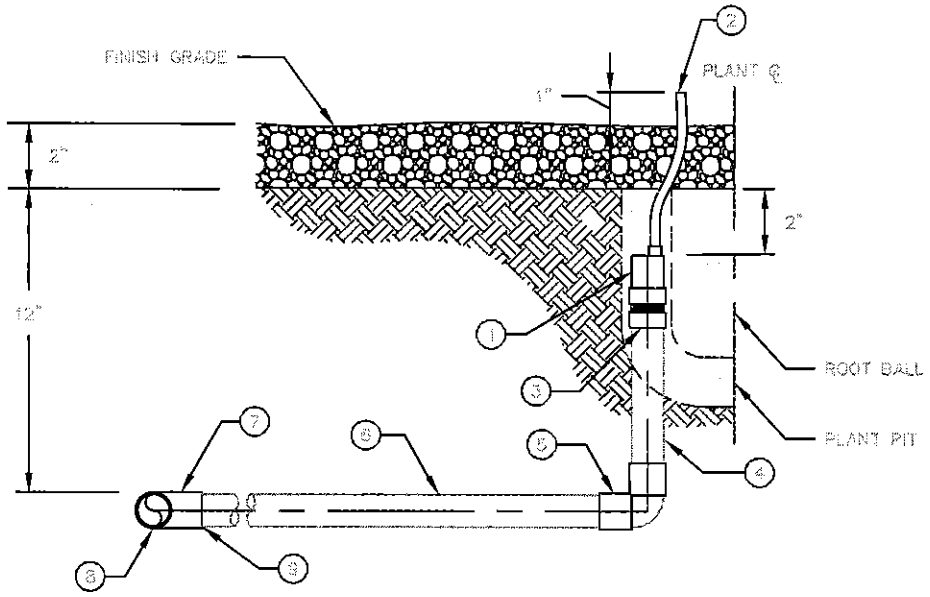

SINGLE OUTLET EMITTER
ALL SHRUBS & GROUND COVER
 SCALE: NTS

LIST OF MATERIALS

- ① BOWSMITH SL - SERIES SINGLE PORT EMITTER OR APPROVED EQUAL. LOCATE ON UPHILL SIDE OF PLANT CENTERLINE.
- ② 1/4" POLY FLEX HOSE EMITTER TUBING
- ③ 1/2" PVC SCH 40 MALE ADAPTOR
- ④ AG. PRODUCTS - 1/2" I.P.S. FLEXIBLE VINYL PVC PIPE OR APPROVED EQUAL
- ⑤ 1/2" PVC SCH 40 90° ELBOW
- ⑥ 1/2" PVC CL 315 PIPE
- ⑦ 1/2" PVC SCH 40 FITTING
- ⑧ PVC CL 315 FOR 1/2" LATERALS, PVC CL 200 FOR LATERALS GREATER THAN 1/2"
- ⑨ INSTALL BUSHING AS REQUIRED.

NOTES

- 1. PIPE CEMENT & PRIMER SHALL BE AS SPECIFIED BY MANUFACTURER FOR FLEXIBLE AND RIGID PIPE CONNECTIONS.
- 2. EMITTER TUBING EMISSION POINTS SHALL BE EQUALLY SPACED AND LOCATED TO DIRECT WATER FLOW TO THE PERIMETER OF THE DRIP LINE.
- 3. NUMBER OF OPENINGS AND EMITTER TUBES REQUIRED IS BASED ON PLANT SIZE. (SEE COS STD. DET. 2641-2)
- 4. MAXIMUM EMITTER TUBING LENGTH = 36'.

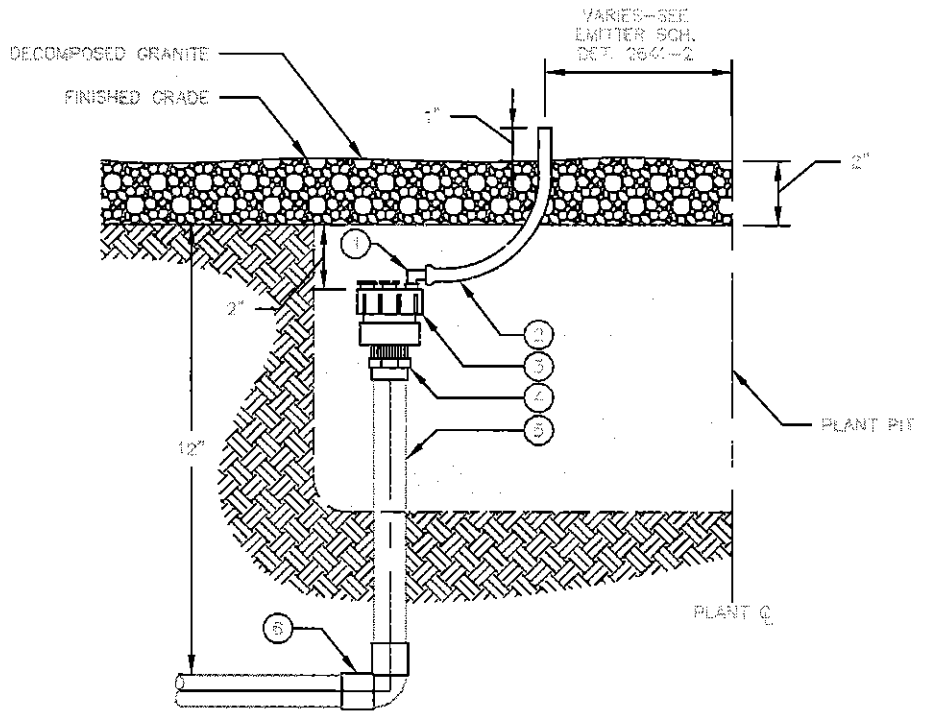

MULTI-OUTLET EMITTER
TREES ONLY
 SCALE: NTS

LIST OF MATERIALS

- ① SWIVEL OUTLET 90° ELBOW
- ② 1/4" POLY FLEX HOSE EMITTER TUBING
- ③ BOWSMITH ML 200 SERIES MULTI-PORT EMITTER OR APPROVED EQUAL. LOCATE ON UPHILL SIDE OF PLANT C.
- ④ 1/2" PVC SCH 40 MALE ADAPTER
- ⑤ AG. PRODUCTS 1/2" I.P.S. FLEXIBLE VINYL PVC PIPE OR APPROVED EQUAL
- ⑥ 1/2" PVC SCH 40 FITTING

DETAIL NO. 2641-1 City of Scottsdale Standard Details

SINGLE & MULTI-OUTLET EMITTERS

DETAIL NO. 2641-1

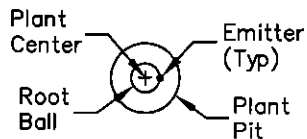

**SHRUB EMITTER
SINGLE OUTLET**

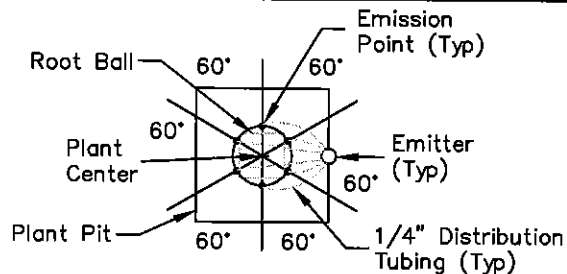

**TREE EMITTER - MULTI OUTLET
15 GAL TO 42" BOX TREES**

(SEE EMITTER SCHEDULE)

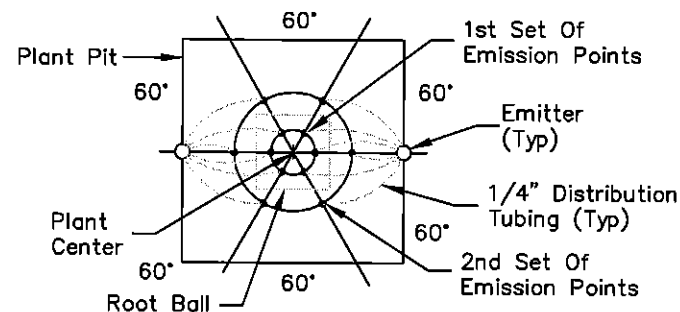

**TREE EMITTER - MULTI OUTLET
48" BOX TO 60" BOX TREES**

(SEE EMITTER SCHEDULE)

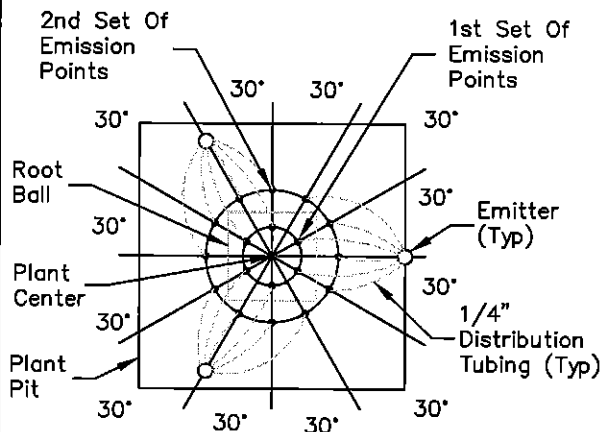

**TREE EMITTER - MULTI OUTLET
66" BOX TO 84" BOX TREES**

(SEE EMITTER SCHEDULE)

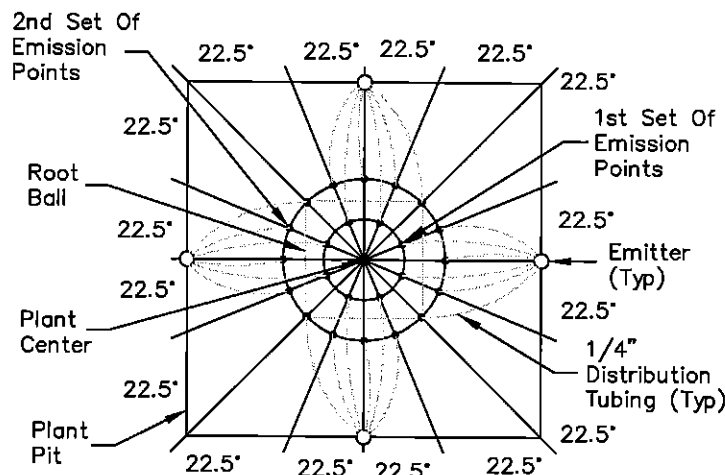

**TREE EMITTER - MULTI OUTLET
96" BOX TREES**

(SEE EMITTER SCHEDULE)

EMITTER SCHEDULE				
Tree Size	Number Of Multi Outlet Emitters - Outlet Quantity = Emitter GPH Total	Distance From Trunk		
		1st Set Of Emission Points	2nd Set Of Emission Points	
15 Gal.	1-1 GPH=6 GPH	3 @ 12"		
24" Box	1-1 GPH=6 GPH	4 @ 18"		
30" Box	1-1 GPH=6 GPH	6 @ 21"		
36" Box	1-2 GPH=12 GPH	6 @ 24"		
42" Box	1-2 GPH=12 GPH	6 @ 27"		
48" Box	2-2 GPH=24 GPH	6 @ 12"	4 @ 42"	
54" Box	2-2 GPH=24 GPH	6 @ 15"	5 @ 45"	
60" Box	2-2 GPH=24 GPH	6 @ 18"	6 @ 48"	
66" Box	3-2 GPH=36 GPH	6 @ 24"	12 @ 54"	
72" Box				
78" Box	3-2 GPH=36 GPH	6 @ 30"	12 @ 60"	
84" Box				
≥ 90" Box	4-2 GPH=48 GPH	8 @ 33"	16 @ 66"	

REVISED 7/29/96

DETAIL NO. **2641-2** City of Scottsdale
Standard Details

APPROVED BY: _____

IRRIGATION EMITTER LAYOUT

DETAIL NO. **2641-2**

REVISED: 7/15/03

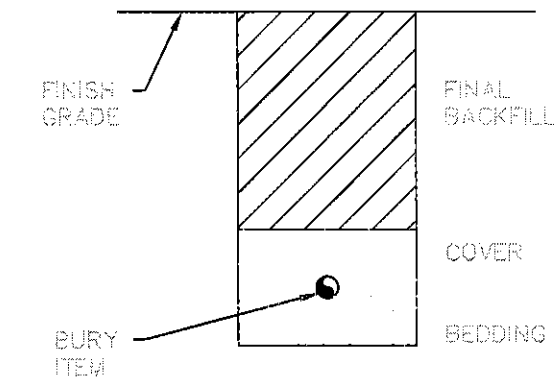
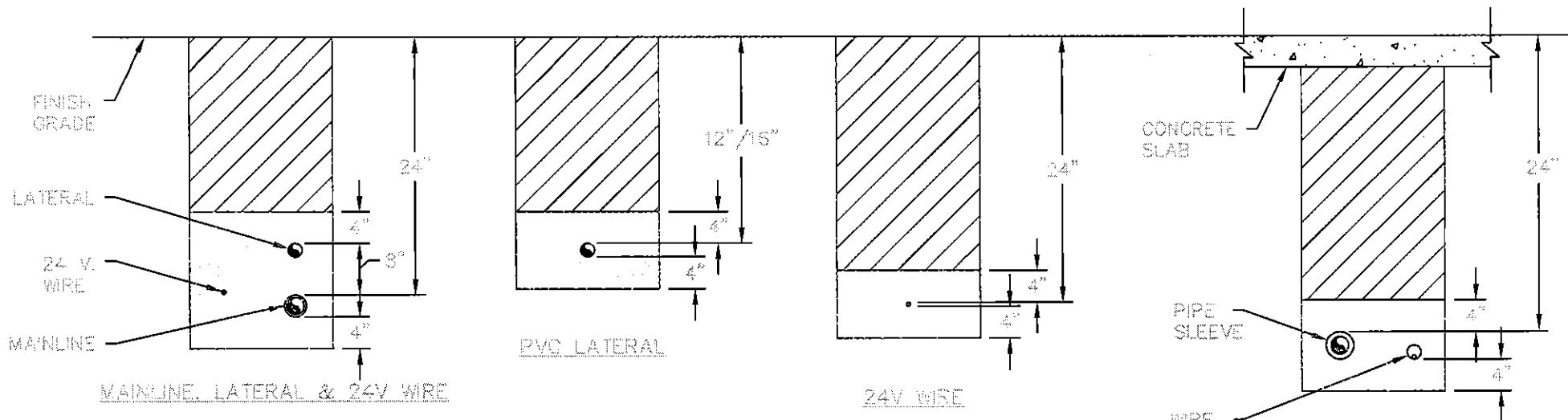

EXCAVATED MATERIAL SHALL BE FINELY SCREENED WITH NO ROCKS LARGER THAN 1".

BEDDING AND COVER MATERIAL SHALL BE TOPSOIL WITH NO ROCKS.

NOTES:

1. BEDDING SHALL BE PLACED AND LEVELED PRIOR TO INSTALLATION OF BURY ITEM.
2. BACKFILL SHALL BE PLACED IN MAXIMUM 6" LIFTS.
3. SLEEVE ALL PIPE AND WIRE SEPARATELY. SLEEVE 2 X DIA. OF PIPE. ONE PIPE PER SLEEVE.
4. ALL PIPE TO BE INSTALLED PER MANUFACTURERS SPECIFICATIONS WITH PIPE LABELING FACING UP FOR INSPECTION PURPOSES. PROVIDE A MINIMUM OF 2" CLEARANCE TO SIDE OF TRENCH AND BETWEEN PIPES.
5. ALL 120 V. WIRING SHALL BE INSTALLED IN ACCORDANCE WITH LOCAL CODE REQUIREMENTS.
6. TAPE AND BUNDLE IRRIGATION CONTROL WIRES EVERY 10'. PROVIDE LOOSE 20" LOOP AT ALL CHANGES OF DIRECTION OVER 30'.
7. ALL REMOTE CONTROL VALVE WIRING NOT INSTALLED WITH MAINLINE PIPE SHALL BE INSTALLED IN A MINIMUM 2" SCHEDULE 40 GREY ELECTRICAL CONDUIT OR AS APPROVED.
8. "NON-POTABLE" WARNING TAPE TO BE INSTALLED ON PRESSURIZED MAINLINES 3" AND ABOVE.

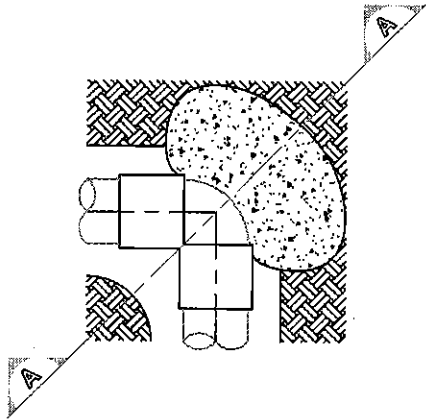

90° ELL

SCALE: NTS

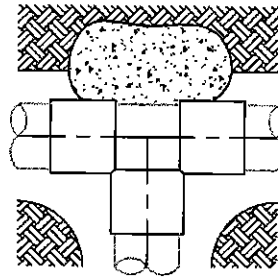

TEE

SCALE: NTS

PIPE SIZE	MINIMUM THRUST BLOCK AREA (Y&W)	
	TEE, DEAD END	IRRIGATION PIPE
2" & LESS	1 SF	9 SF
3"	1.5 SF	1 SF
4"	2 SF	1.5 SF
5" & LARGER	PER MAG DETAIL 380	PER MAG DETAIL 380

NOTES

1. MINIMUM THRUST BLOCK AREAS ARE BASED ON A SOIL BEARING CAPACITY OF 3000 LBS/SF
2. THRUST BLOCK SHALL EXTEND INTO UNDISTURBED SOIL.
3. THRUST BLOCK SHALL BE MAG SECT. 725—CLASS C.

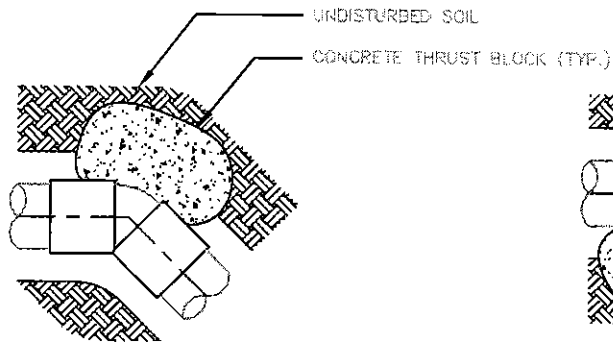

45° ELL

SCALE: NTS

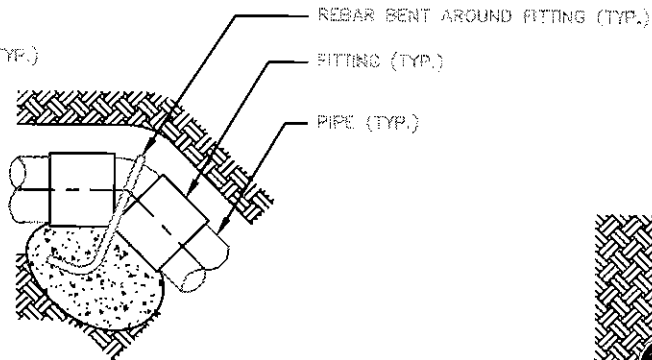

45° ELL (VERTICAL)

SCALE: NTS

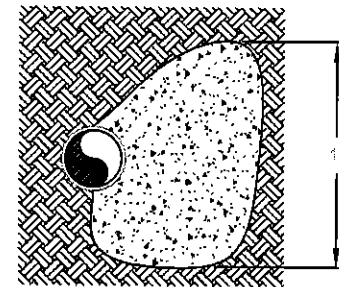
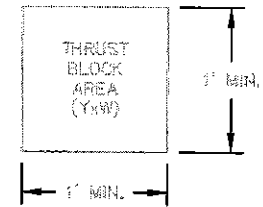

SECTION

A

DETAIL NO.
2643

City of Scottsdale
Standard Details

IRRIGATION THRUST BLOCK

DETAIL NO.
2643

REVISED: 1/11/90

REVISED: 2/27/02

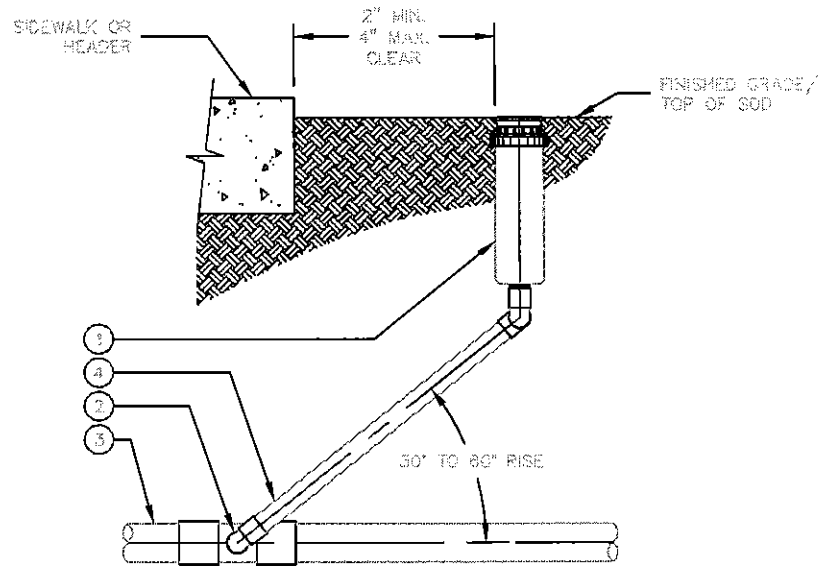

SWING JOINT ASSEMBLY ELEVATION

SCALE: NTS

LIST OF MATERIALS

- ① ROTOR SPRINKLER HEAD
- ② STREET ELL (1 OF 3) SCH 40 PVC
- ③ PVC LATERAL PIPE
- ④ SCH 80 NIPPLE TGE

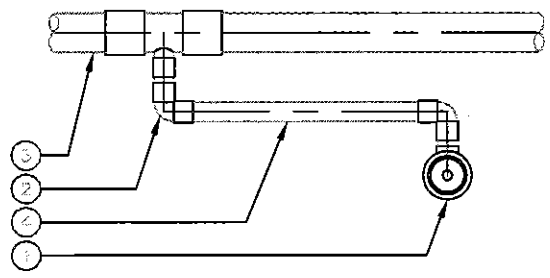

SWING JOINT ASSEMBLY PLAN

SCALE: NTS

NOTES

- 1. SWING JOINT TO BE THE SAME SIZE AS SPRINKLER HEAD INLET.
- 2. NO PRE-FAB SWING JOINTS
- 3. NO MARLEX FITTINGS

DETAIL NO.
2644

City of Scottsdale
Standard Details

ROTOR SPRINKLER ASSEMBLY

DETAIL NO.
2644

REVISED: 2/27/02

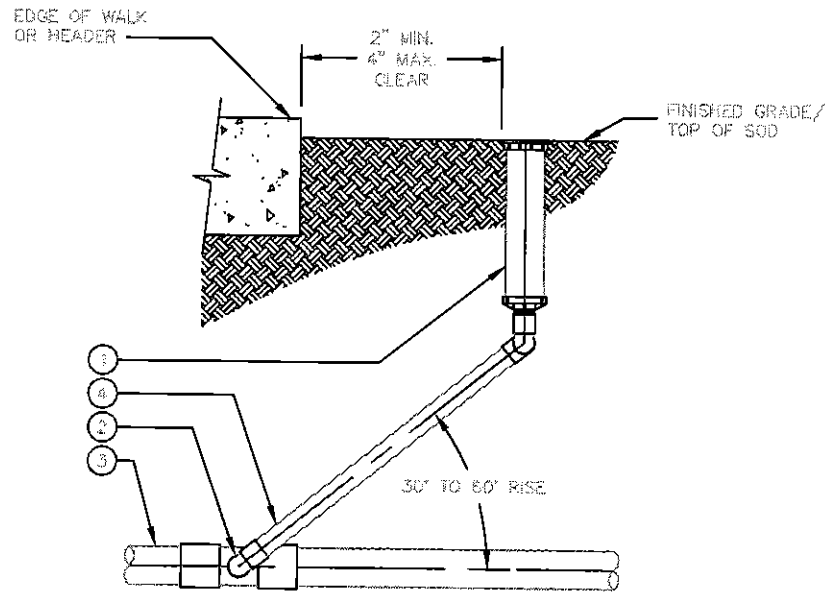

**SWING JOINT ASSEMBLY
ELEVATION**

SCALE: NTS

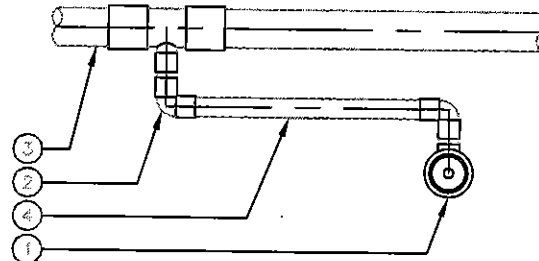

SWING JOINT ASSEMBLY PLAN

SCALE: NTS

LIST OF MATERIALS

- ① 4" POP-UP SPRAY SPRINKLER HEAD
- ② STREET ELL (1 OF 3) SCH 40 PVC
- ③ PVC LATERAL PIPE
- ④ SCH 80 NIPPLE TBE

NOTES

- 1. SWING JOINT TO BE THE SAME SIZE AS SPRINKLER HEAD INLET.
- 2. NO PRE-FAB SWING JOINTS
- 3. NO MARLEX FITTINGS

DETAIL NO.
2645

City of Scottsdale
Standard Details

POP-UP SPRINKLER ASSEMBLY

DETAIL NO.
2645

REVISED: 7/27/02

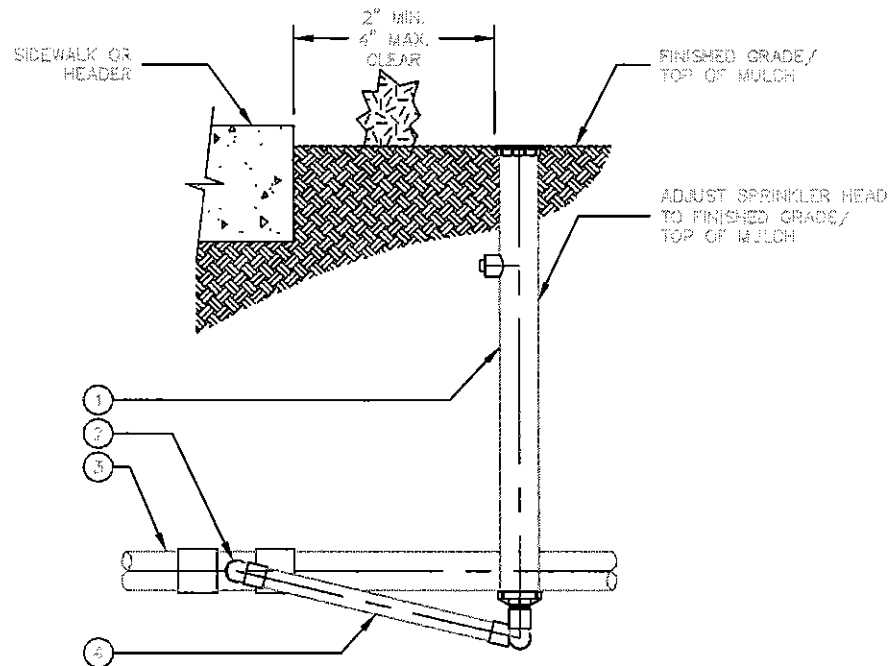

SWING JOINT ASSEMBLY ELEVATION

SCALE: NTS

LIST OF MATERIALS

- ① 12" POP-UP SPRAY SPRINKLER HEAD
- ② STREET ELL (1 OF 3) SCH 40 PVC
- ③ PVC LATERAL PIPE
- ④ SCH 80 NIPPLE TBE

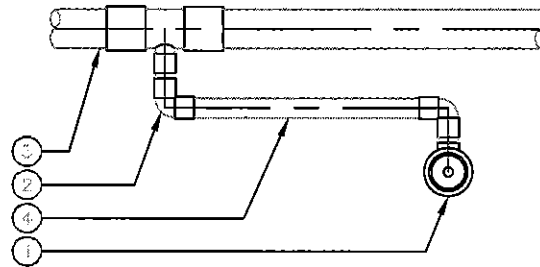

SWING JOINT ASSEMBLY PLAN

SCALE: NTS

NOTES

- 1. SWING JOINT TO BE THE SAME SIZE AS SPRINKLER HEAD INLET.
- 2. SWING JOINT SHALL BE CONNECTED TO BOTTOM OUTLET.
- 3. NO PRE-FAB SWING JOINTS
- 4. NO MARLEX FITTINGS

DETAIL NO.
2646

City of Scottsdale
Standard Details

SHRUB POP-UP SPRINKLER ASSEMBLY

DETAIL NO.
2646

REVISED: 7/15/03

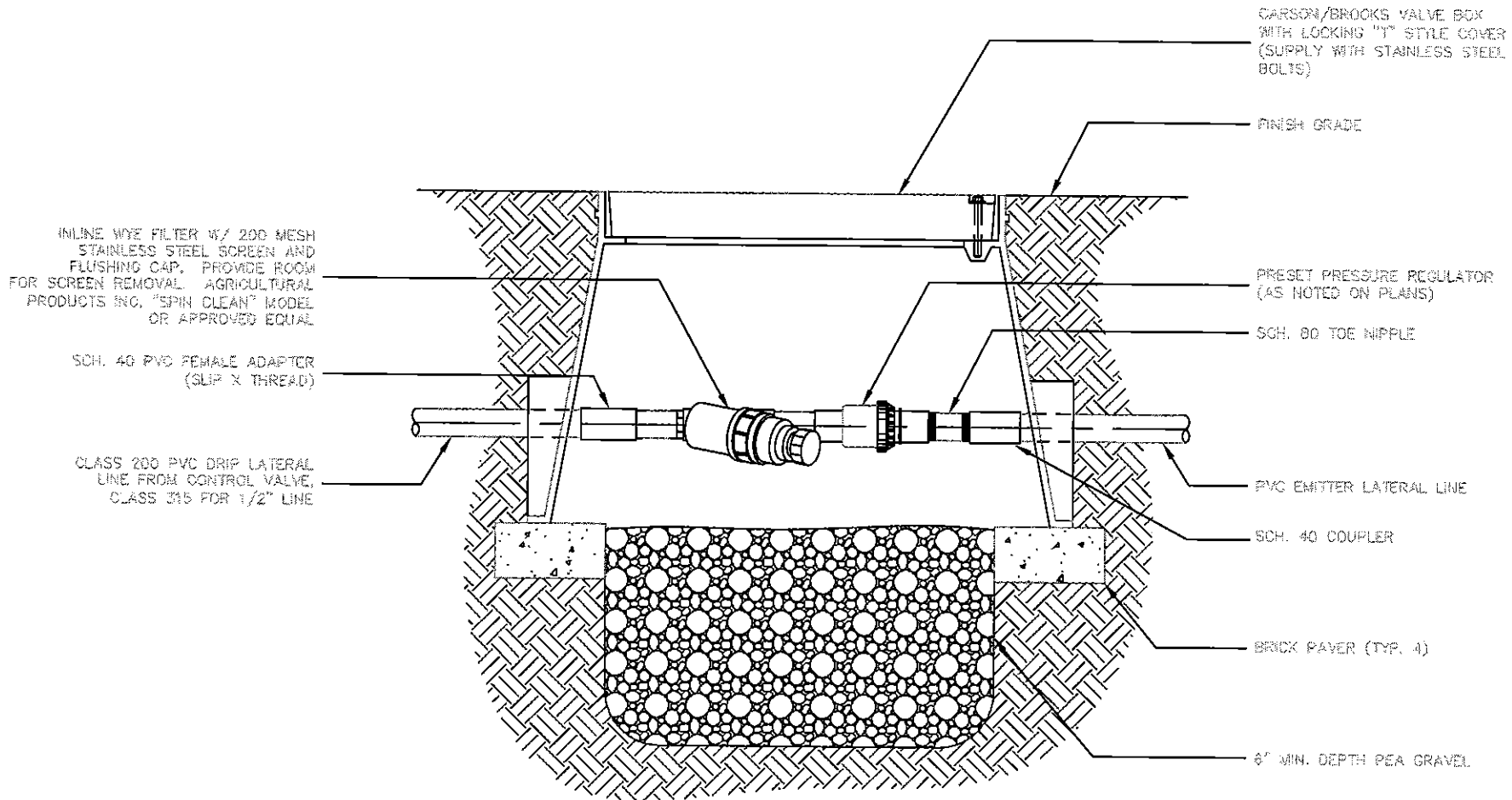

**DRIP FILTER &
PRESS. REG. ASSEMBLY**

SCALE: NTS

DETAIL NO. 2647	City of Scottsdale Standard Details	DRIP FILTER & PRESSURE REGULATOR	DETAIL NO. 2647
--------------------	--	---	--------------------

REVISED: 1/5/00

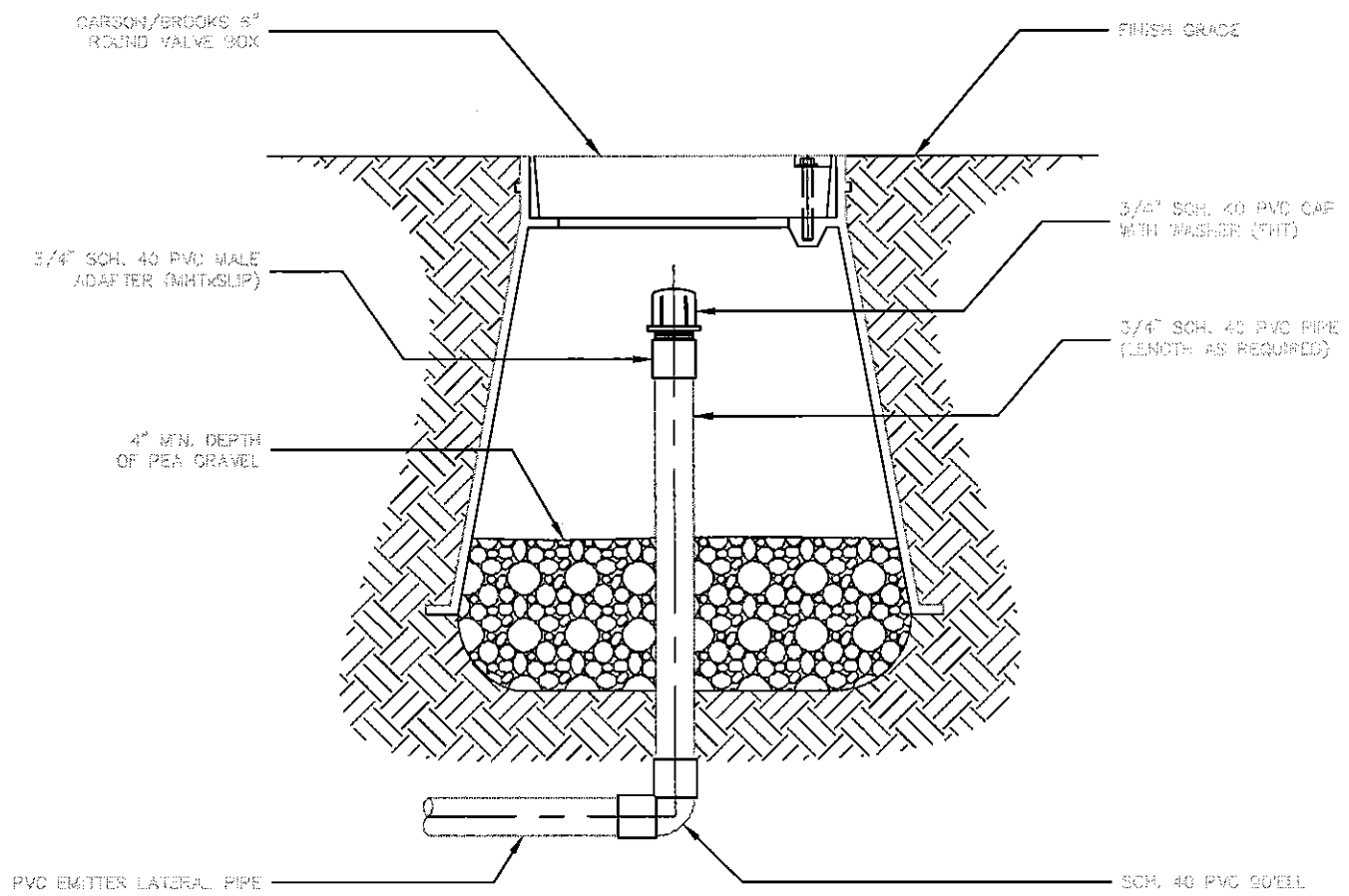

EMITTER FLUSH CAP ASSEMBLY
 SCALE: NTS

DETAIL NO. 2848	City of Scottsdale Standard Details	EMITTER FLUSH CAP ASSEMBLY	DETAIL NO. 2848
---------------------------	--	-----------------------------------	---------------------------

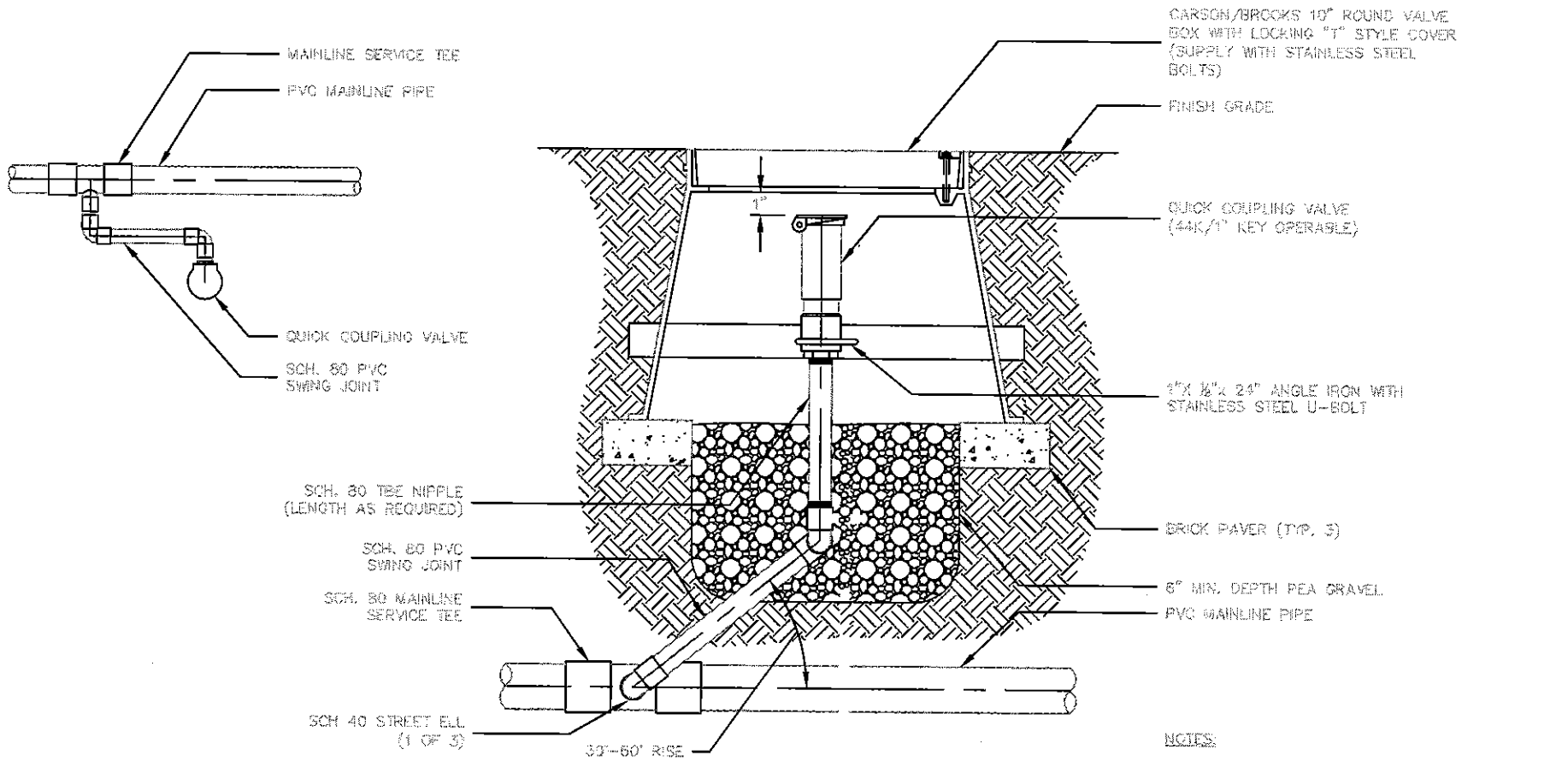

CARSON/BROOKS 10" ROUND VALVE BOX WITH LOCKING "T" STYLE COVER (SUPPLY WITH STAINLESS STEEL BOLTS)

FINISH GRADE

QUICK COUPLING VALVE (44K/1" KEY OPERABLE)

1 1/2" x 1/2" x 2 1/2" ANGLE IRON WITH STAINLESS STEEL U-BOLT

BRICK PAVER (TYP. 3)

6" MIN. DEPTH PEA GRAVEL

PVC MAINLINE PIPE

MAINLINE SERVICE TEE
PVC MAINLINE PIPE

QUICK COUPLING VALVE
SCH. 80 PVC SWING JOINT

SCH. 80 TEE NIPPLE (LENGTH AS REQUIRED)

SCH. 80 PVC SWING JOINT

SCH. 80 MAINLINE SERVICE TEE

SCH. 40 STREET ELL (1 OF 3)

30"-60" RISE

NOTES:

1. EACH QUICK COUPLER SHALL BE IN A SEPARATE VALVE BOX.
2. SWING JOINT SHALL BE THE SAME SIZE AS QUICK COUPLER VALVE.
3. NO PRE-FAB SWING JOINTS.
4. U-BOLT TO BE SECURED WITH LOCK WASHERS AND BACK-UP LOCKING NUT.

QUICK COUPLER ASSEMBLY
SCALE: NFE

REVISED: 7/15/03

SIZE:

1. BALL VALVE SHALL MATCH NOMINAL SIZE OF MAINLINE PIPE.

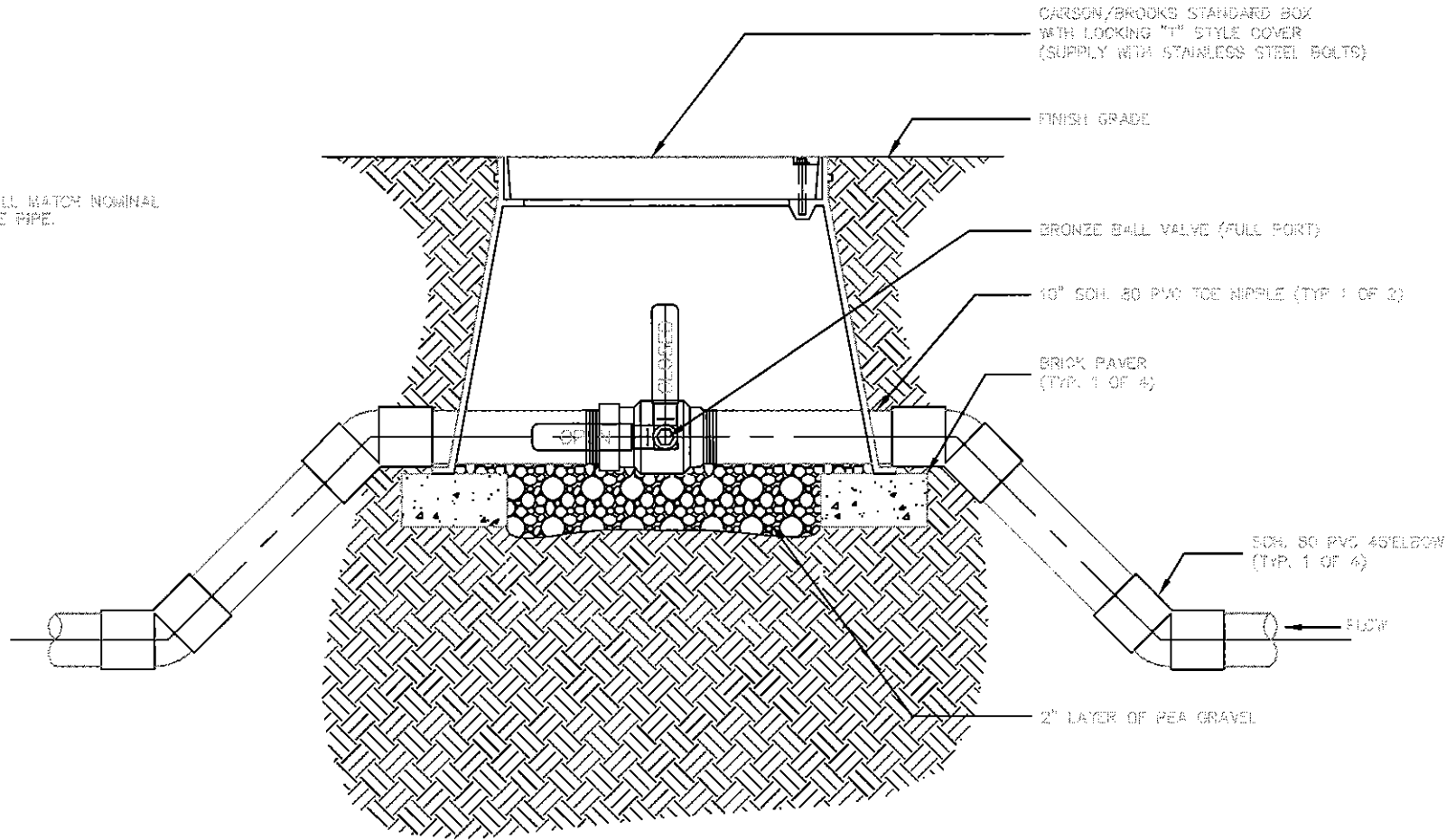

1-1/2" & SMALLER MAINLINE ISOLATION BALL VALVE ASSEMBLY
SCALE: N/A

DETAIL NO.
2650

City of Scottsdale
Standard Details

1-1/2" & SMALLER MAINLINE BALL VALVE

DETAIL NO.
2650

REVISED: 7/15/03

NOTE:

- 1. GATE VALVE SHALL MATCH NOMINAL SIZE OF MAINLINE PIPE.
- 2. PROTECT VALVE BODY WITH 10MIL PLASTIC PRIOR TO INSTALLATION OF REBAR & SUPPORT BLOCK.

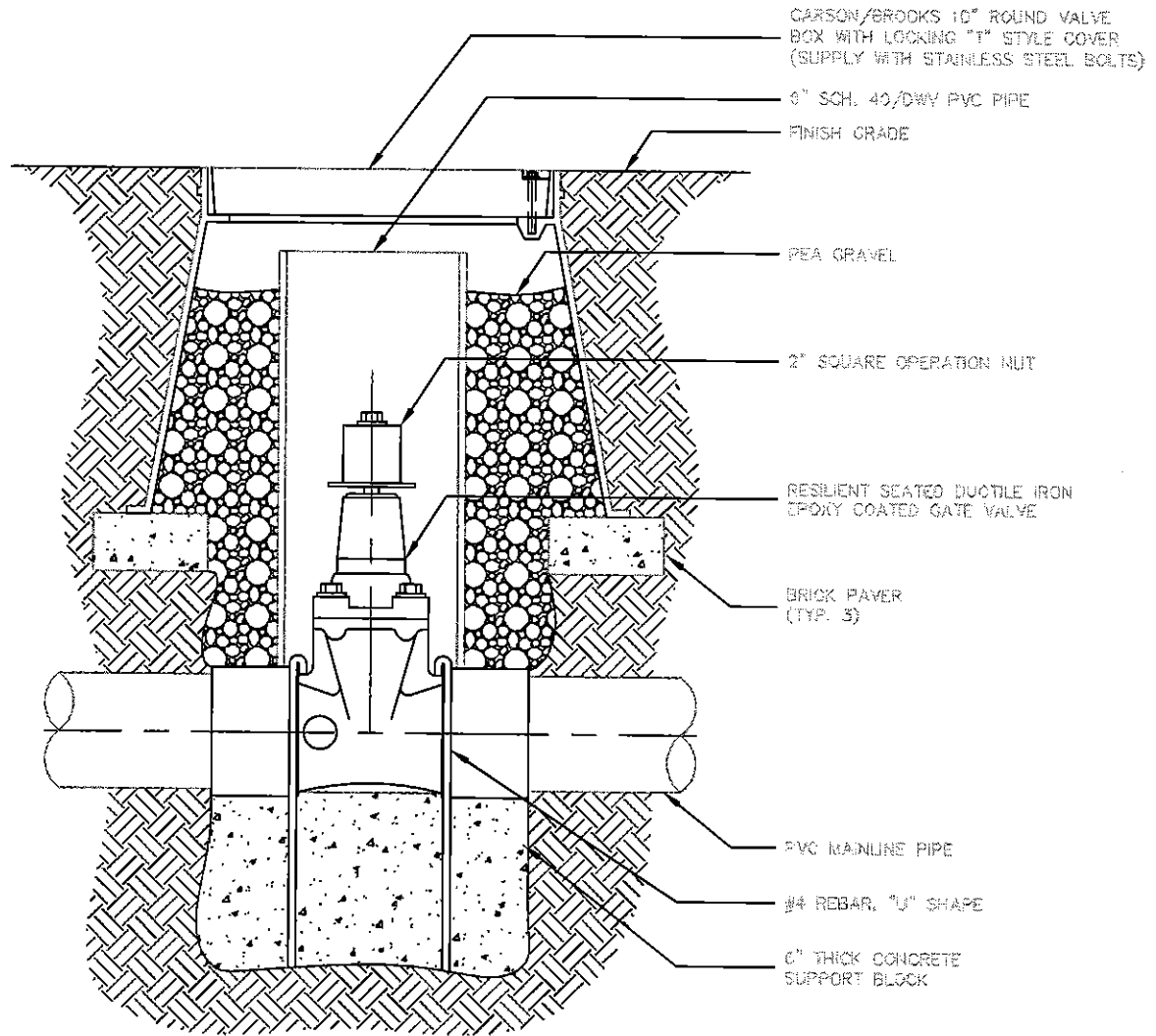

2" & LARGER MAINLINE ISOLATION GATE VALVE ASSEMBLY

SCALE: NTS

DETAIL NO. 2651 City of Scottsdale Standard Details

2" & LARGER MAINLINE ISOLATION GATE VALVE

DETAIL NO. 2651

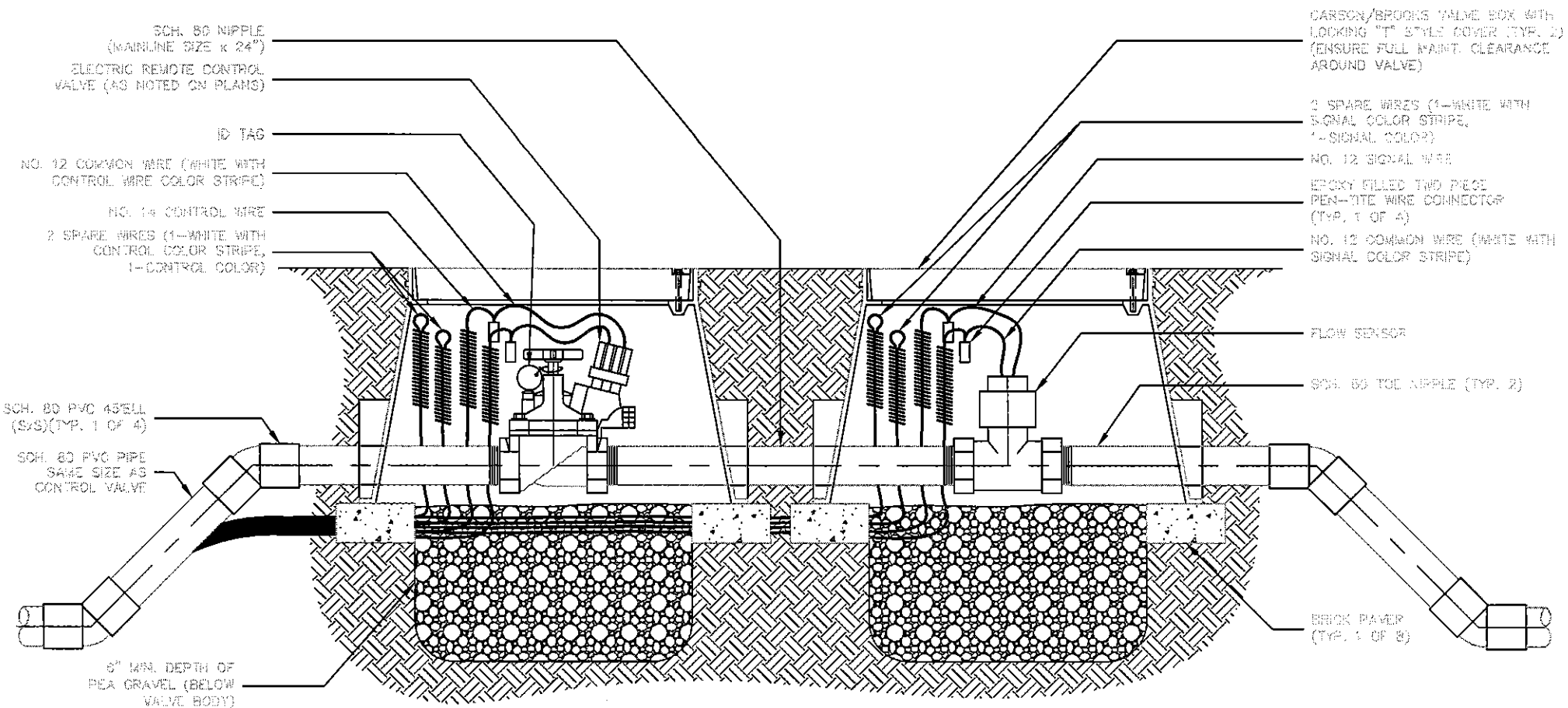

FLOW →

**1" MASTER VALVE /
FLOW METER ASSEMBLY**
SCALE: NTS

NOTES:

1. PROVIDE 30" SLACK WIRE IN 3/4" COILS FOR EACH WIRE ENTERING VALVE BOX.
2. INSTALL VALVE I.D. TAG WITH CONTROLLER IDENTIFICATION AND STATION NUMBER WHICH CORRESPONDS TO THE PLANS.
3. MAINTAIN 2" MIN. - 4" MAX. DISTANCE BETWEEN TOP OF CONTROL VALVE AND BOTTOM OF BOX I.D.
4. CONTROL AND SIGNAL WIRE FROM MASTER VALVE TO CONTROLLER TO BE SEPARATE COLOR FROM OTHER VALVE WIRE. (CONTROL AND SIGNAL COMMONS TO BE SEPARATE FROM ANY OTHERS COMMONS IN THE SYSTEM.)
5. A DATA INDUSTRIAL MODEL 600-50 PULSE OUTPUT TRANSMITTER IS REQUIRED TO BE MOUNTED INSIDE THE CONTROLLER CABINET (SEE CITY IRRIGATION SUPERVISOR FOR WIRING INFORMATION).

DETAIL NO. 2652
City of Scottsdale
Standard Details

1" MASTER VALVE / FLOW METER

DETAIL NO. 2652

REVISED: 7/15/03

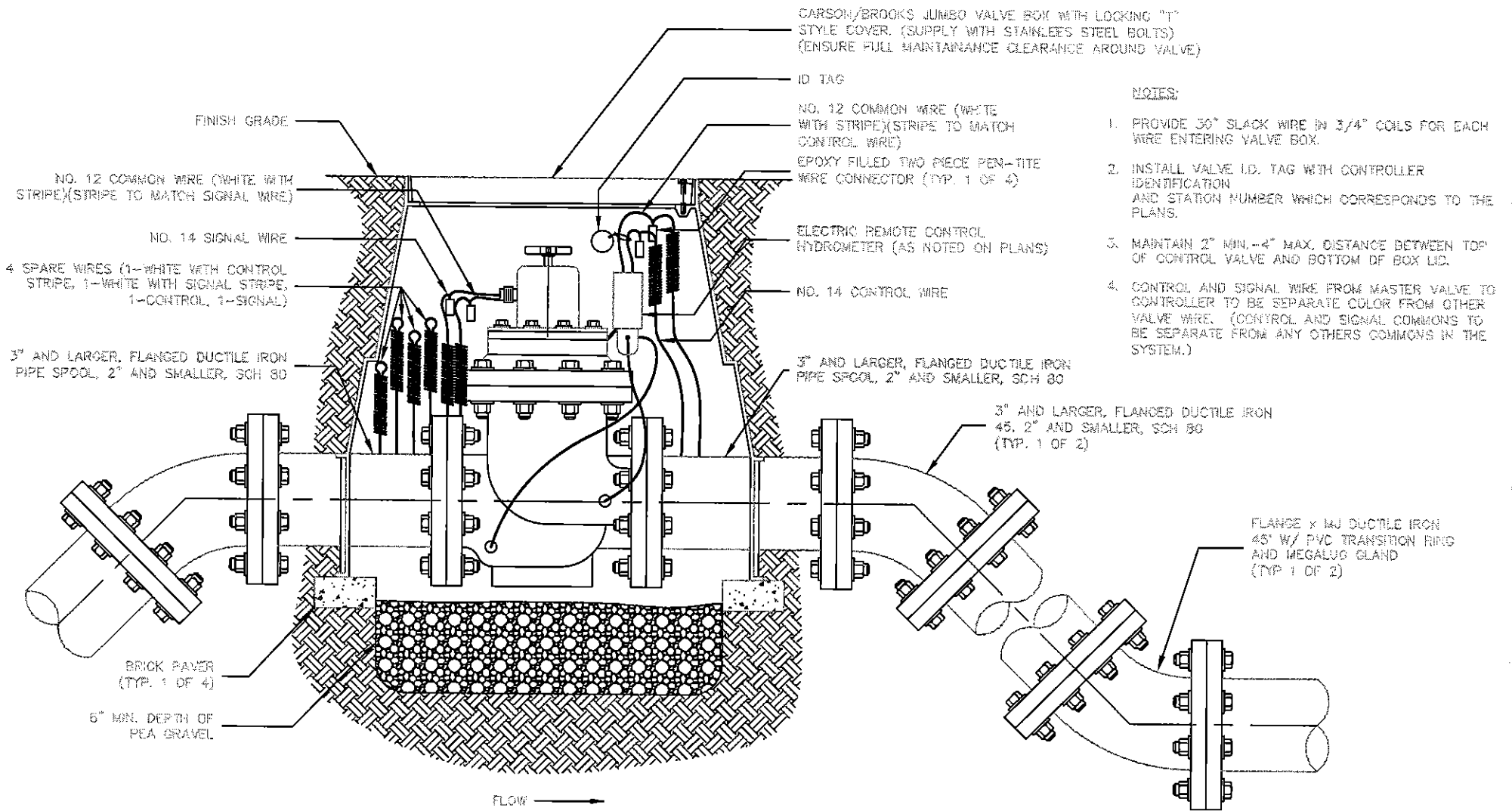

- NOTES:
1. PROVIDE 30" SLACK WIRE IN 3/4" COILS FOR EACH WIRE ENTERING VALVE BOX.
 2. INSTALL VALVE I.D. TAG WITH CONTROLLER IDENTIFICATION AND STATION NUMBER WHICH CORRESPONDS TO THE PLANS.
 3. MAINTAIN 2" MIN. - 4" MAX. DISTANCE BETWEEN TOP OF CONTROL VALVE AND BOTTOM OF BOX I.D.
 4. CONTROL AND SIGNAL WIRE FROM MASTER VALVE TO CONTROLLER TO BE SEPARATE COLOR FROM OTHER VALVE WIRE. (CONTROL AND SIGNAL COMMONS TO BE SEPARATE FROM ANY OTHERS COMMONS IN THE SYSTEM.)

1 1/2" LARGER MASTER VALVE / FLOW METER ASSEMBLY

SCALE: NTS

DETAIL NO. 2653 City of Scottsdale Standard Details

1 1/2" & LARGER MASTER VALVE/FLOW METER

DETAIL NO. 2653

2/1/0

REVISED: 7/15/03

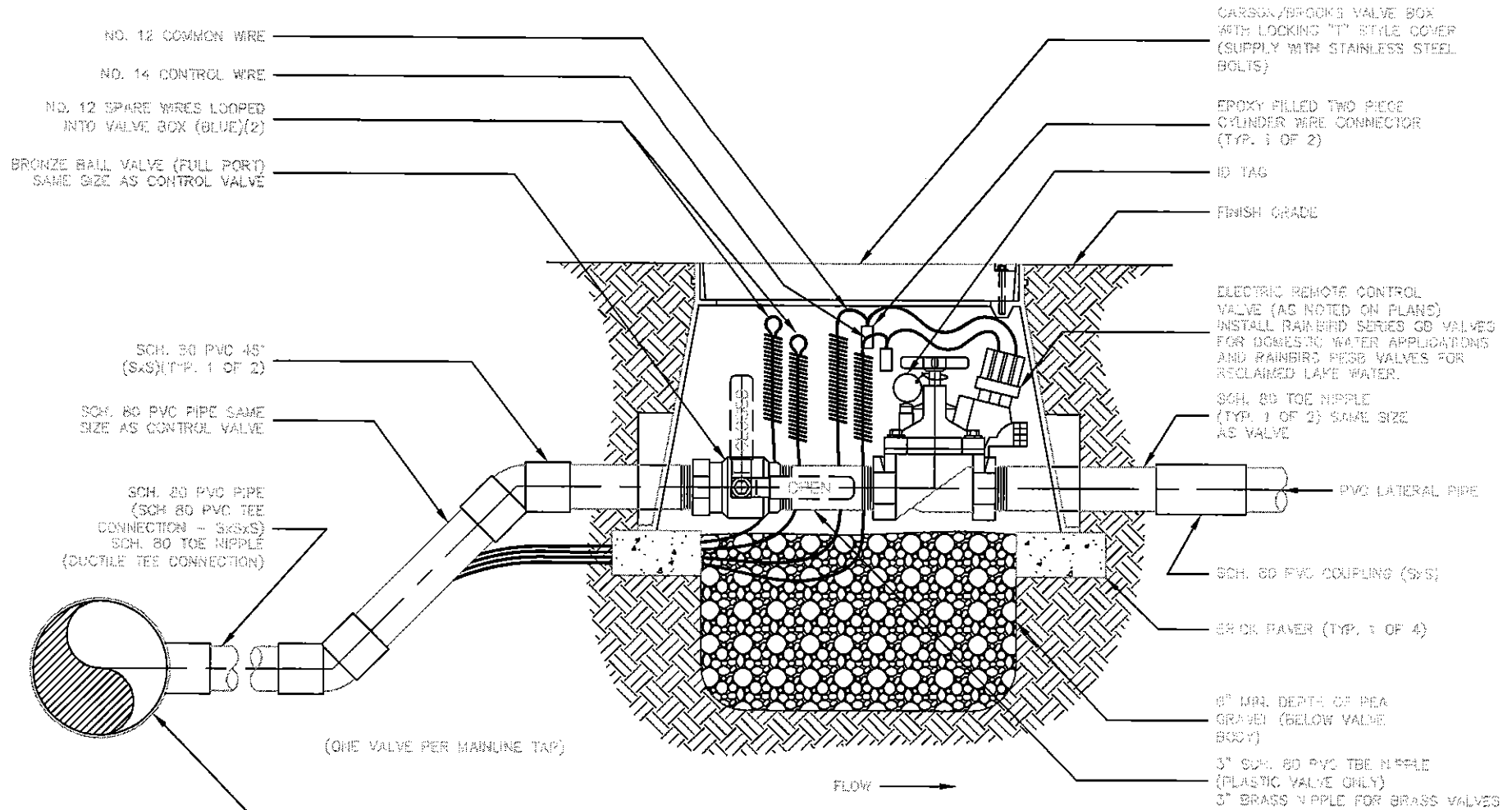

(ONE VALVE PER MAINLINE TAP)

FLOW →

REMOTE CONTROL VALVE ASSEMBLY

SCALE: NTS

NOTES:

1. PROVIDE 30' BLACK WIRE IN 3/4" COILS FOR EACH WIRE ENTERING VALVE BOX.
2. INSTALL VALVE ID TAG WITH CONTROLLER IDENTIFICATION AND STATION NUMBER WHICH CORRESPONDES TO THE PLANS.
3. MAINTAIN 2" MIN.-4" MAX. DISTANCE BETWEEN TOP OF CONTROL VALVE AND BOTTOM OF BOX LID.
4. INSTALL D.C. LATCHING SOLENOIDS W/ D.C. CONTROLLERS.
5. FOR BRASS CONTROL VALVES, INSTALL 3" BRASS TEE NIPPLE BETWEEN BALL VALVE AND CONTROL VALVE.

DETAIL NO.
2054

City of Scottsdale
Standard Details

REMOTE CONTROL VALVE ASSEMBLY

DETAIL NO.
2054

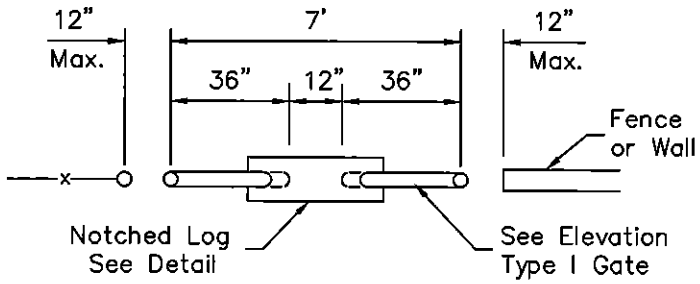

**TYPE I GATE
w/ NOTCHED LOG**

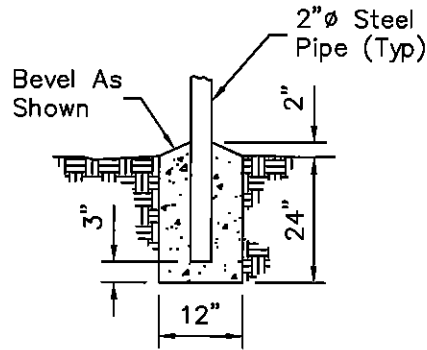

**POST FOOTING
DETAIL**

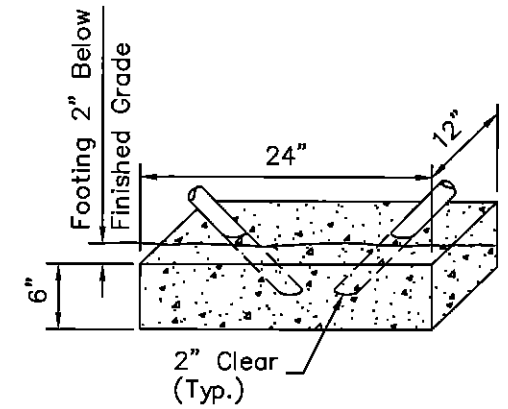

**GATE FOOTING
DETAIL**

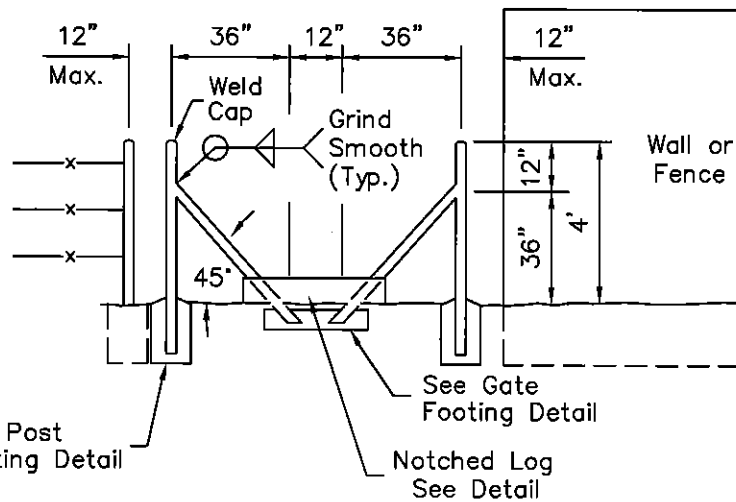

**ELEVATION
TYPE I GATE**

NOTES:

1. All Concrete Shall Be Class "B".
2. Paint Rails Per ADOT Specifications. Color Per Plans.
3. Treated Wood Per MAG Section 779.

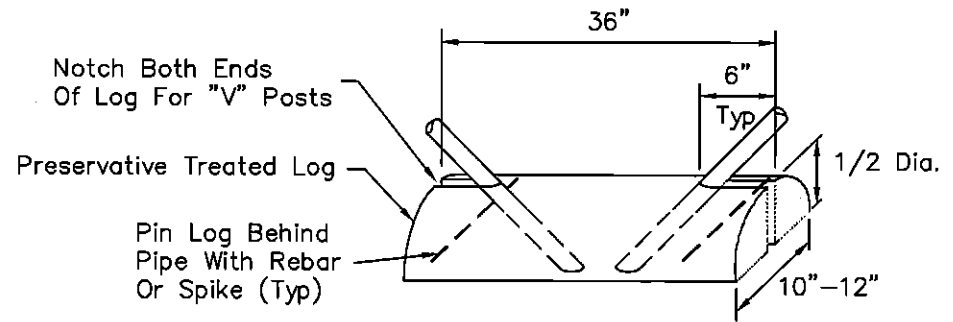

NOTCHED LOG DETAIL

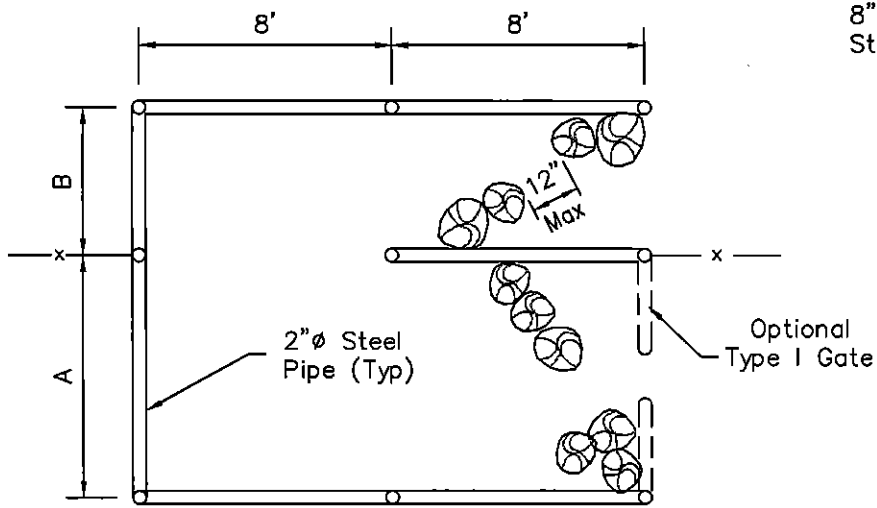

TYPE II GATE

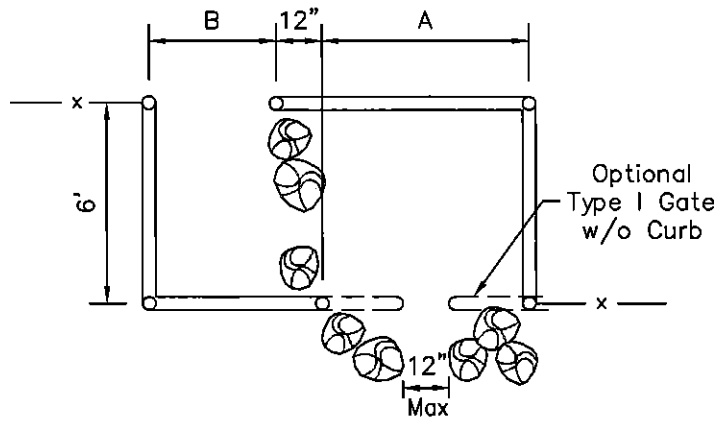

TYPE III GATE

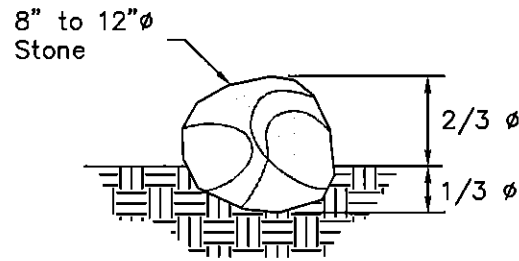

**BURIED STONE
DETAIL**

NOTE:

Gate barriers for Type II, III and IV gates shall be buried stones or Type I gate as shown on plan.

TYPE II and III GATE DIMENSIONS		
GATE BARRIER	A	B
Type I	7'	4'
Buried Rocks	4'	4'

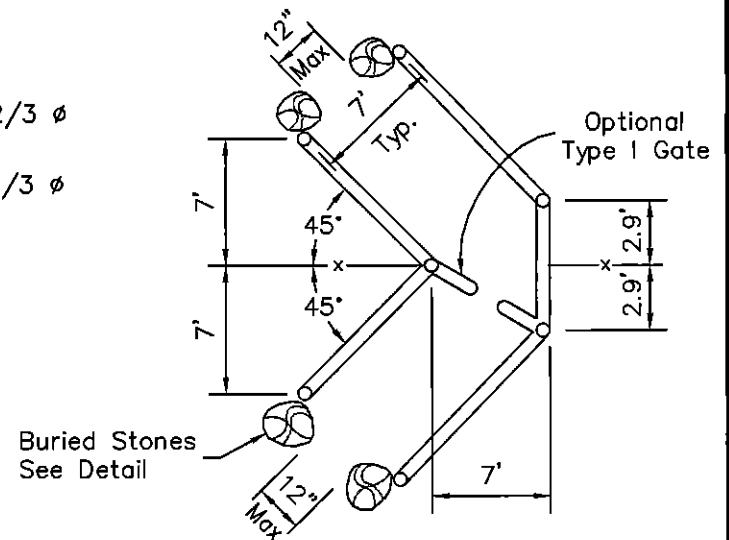

TYPE IV GATE

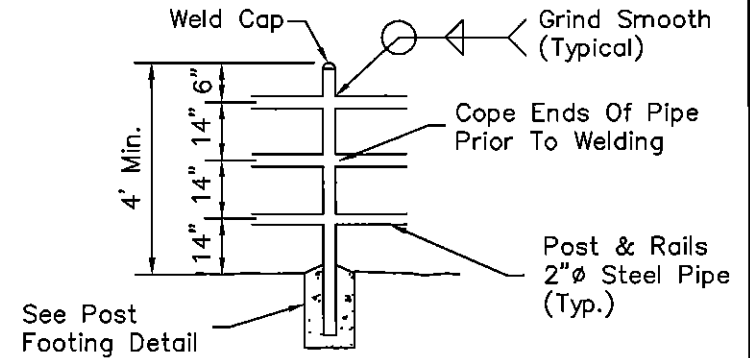

**TYPICAL RAIL ELEVATION
TYPE II, III & IV GATE**

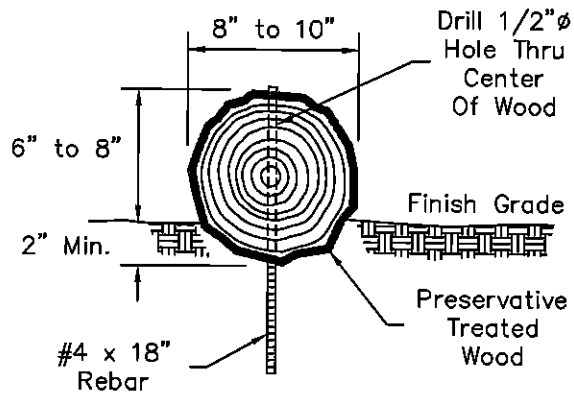

**REBAR SECURED
WOOD BARS**

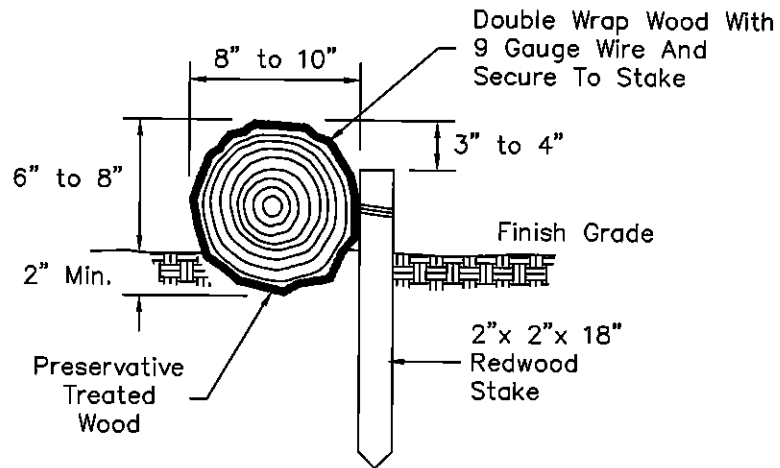

**WIRE SECURED
WOOD BARS**

NOTES:

1. Provide water bars at a maximum 100' interval where trail grade is equal to or greater than 6% and at all locations as shown on plans.
2. Treated wood per MAG Section 779.

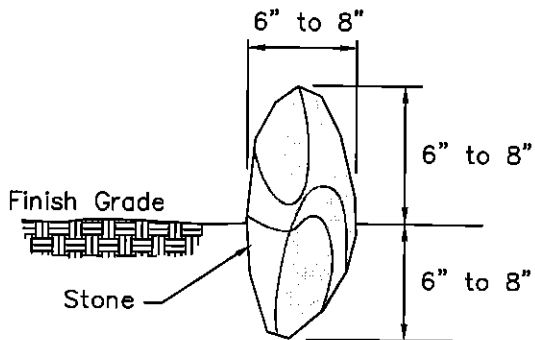

Stagger Stones To Provide A Continuous Water Bar

STONE BARS

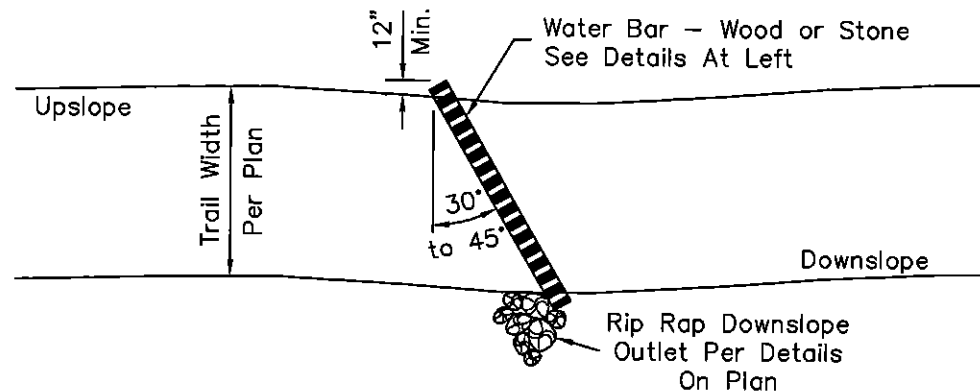

**WATER BARS
PLAN**

DETAIL NO.
2681

**City of Scottsdale
Standard Details**

APPROVED BY:

TRAIL WATER BARS

DETAIL NO.
2681

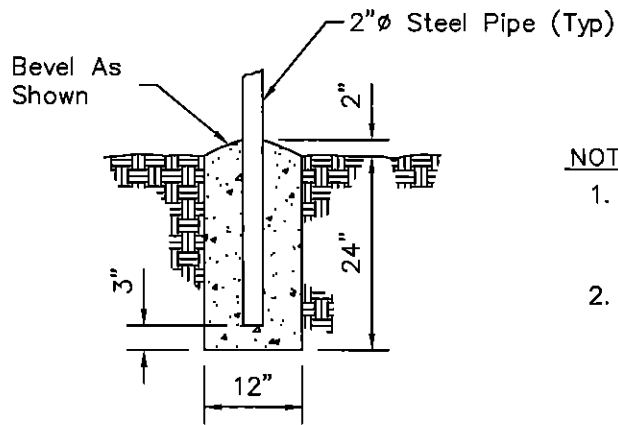

NOTES:

1. Paint Rails Per ADOT Specifications. Color Per Plan.
2. Treated Wood Posts Per MAG Section 779.

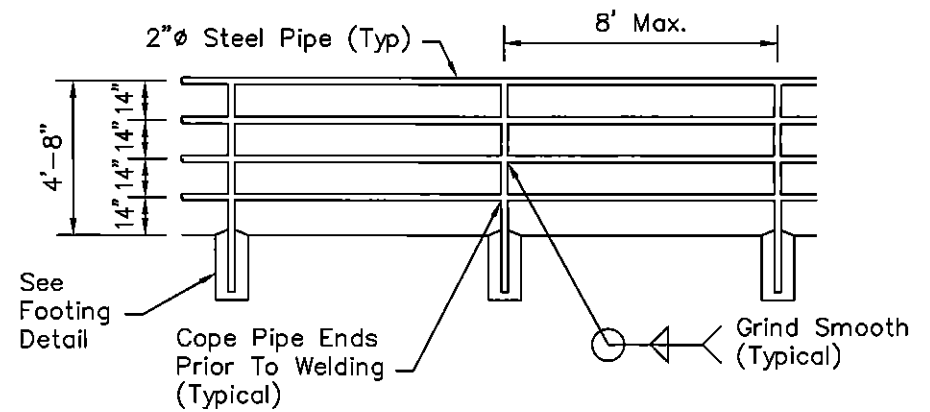

CONCRETE FOOTING DETAIL

STEEL RAIL

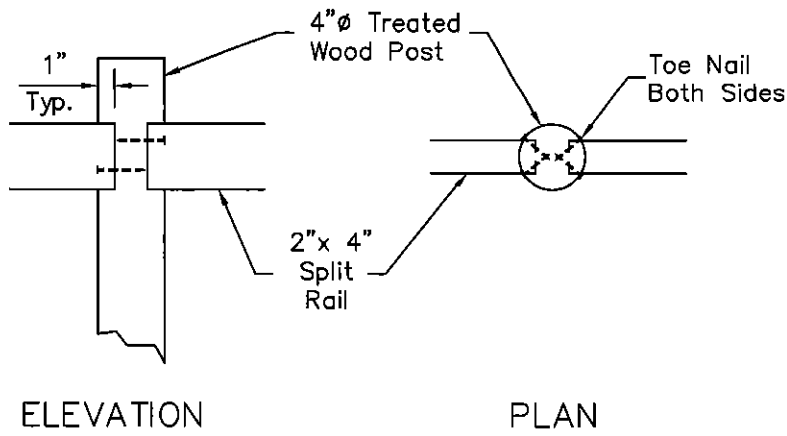

ELEVATION

PLAN

POST CONNECTION DETAIL

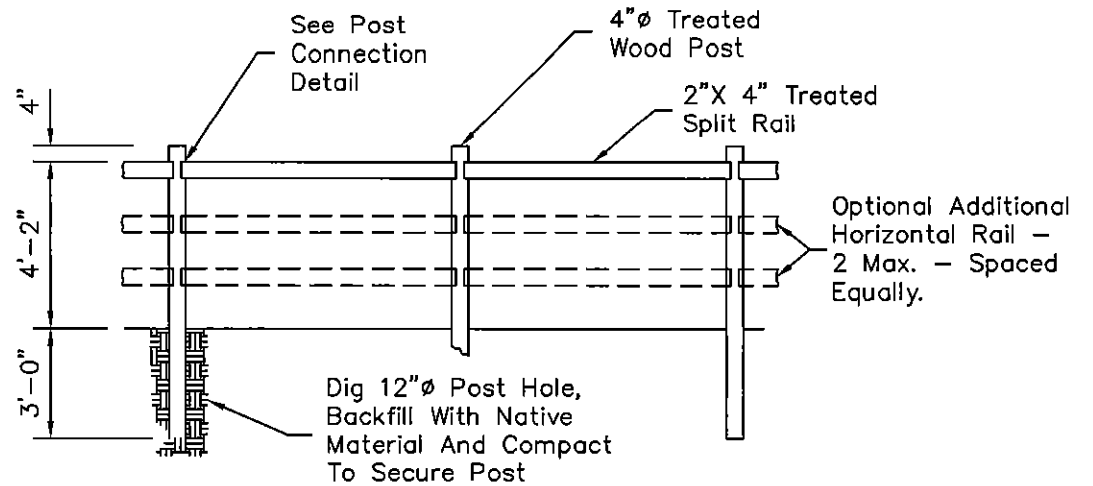

POST AND RAIL

DETAIL NO.
2502

City of Scottsdale
Standard Details

APPROVED BY:

TRAIL SAFETY BARRIERS

DETAIL NO.
2502

NOTES:

1. Signs shall conform to C.O.S. Supplemental Specifications, Section 402.3.
2. Signs to be mounted on square perforated tubing per C.O.S. Std Det 2131 within C.O.S. Right-of-Way. Treated wood post may be used for trail markers located outside C.O.S. Right-of Way.
3. Legends shall be reflectorized white vinyl sheeting on a green or brown vinyl background unless otherwise approved by the City of Scottsdale.

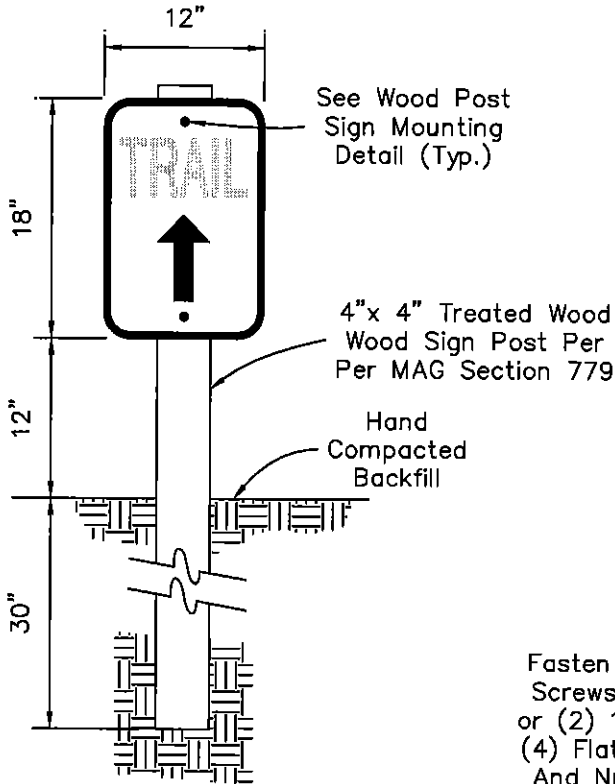

TRAIL MARKER

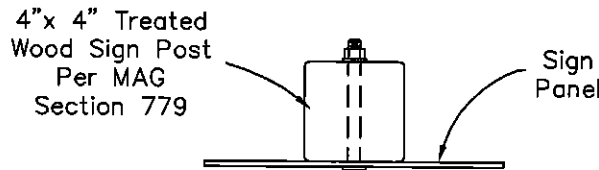

Fasten With (2) 1/2"x 2" Lag Screws With (2) Flat Washers or (2) 1/2"x 4 1/2" Bolts With (4) Flat Washers. Burr Threads And Nuts With Center Punch.

WOOD POST SIGN MOUNTING DETAIL

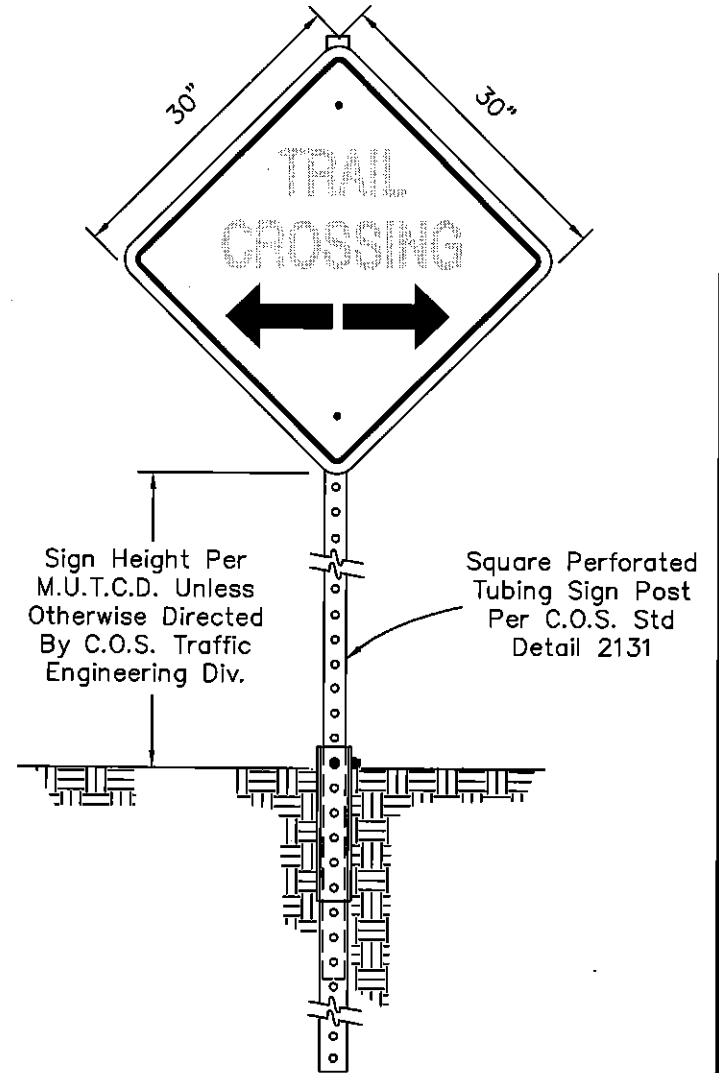

TRAIL CROSSING SIGN

DETAIL NO. 2683 City of Scottsdale Standard Details

APPROVED BY: _____

TRAIL SIGNS

DETAIL NO. 2683