

**CURB OPENING - TYPE 1**  
 RETROFIT OPENING  
 WITH VERTICAL CUT

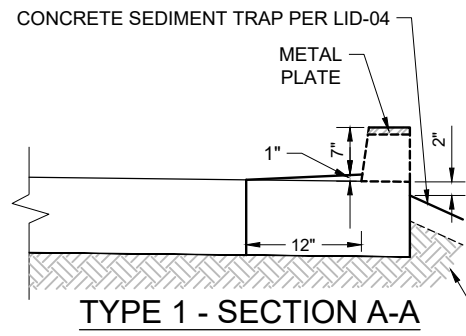

**TYPE 1 - SECTION A-A**

- NOTES:**
1. HEADED CONCRETE ANCHORS SHALL MEET THE REQUIREMENTS OF ASTM A-108.
  2. METAL PLATE 6X2X1/8 CHANNEL SHALL MEET THE REQUIREMENTS OF ASTM A-500 GRADE B.
  3. END PLATES SHALL MEET THE REQUIREMENTS OF ASTM A-36.
  4. ENTIRE ASSEMBLY SHALL BE HOT DIP GALVANIZED IN ACCORDANCE WITH ASTM A-123.
  5. DESIGN VERTICAL WHEEL LOAD IS 8.5 KIPS.
  6. SEE SPECIFICATION 341 FOR MATERIAL AND CONSTRUCTION INFORMATION.
  7. REFER TO AASHTO ROADWAY DESIGN GUIDE FOR CLEAR ZONE REQUIREMENTS FOR SPEED DESIGNS.
  8. DRILL & EPOXY #4x6" REBAR

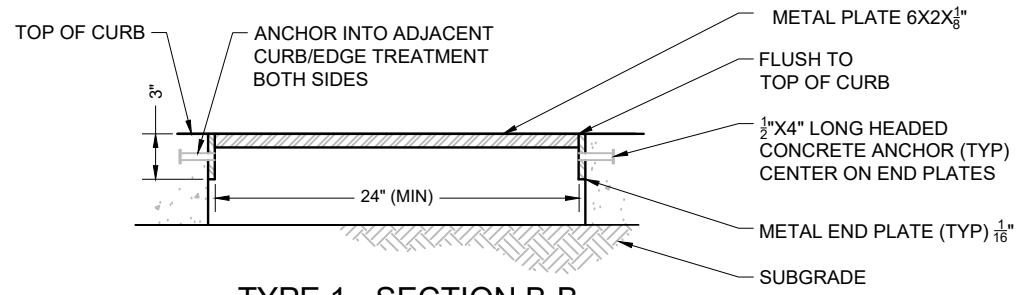

**TYPE 1 - SECTION B-B**

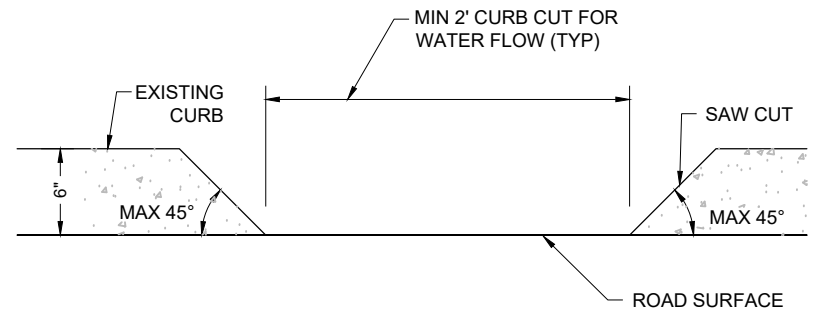

**CURB OPENING - TYPE 2**  
 ANGLED CURB CUT

- NOTES:**
1. DO NOT CUT DEEPER THAN ROAD SURFACE ELEVATION.
  2. ALL CURB OPENINGS SHALL BE MADE BY SAW CUT METHOD.
  3. GRIND EXPOSED METAL AND SEAL TO PROTECT FROM CORROSION.

DETAIL NO. <b>LID-02</b>	<b>STANDARD DETAIL ENGLISH</b>	<b>CURB OPENINGS</b>	REVISED 01-29-2019	DETAIL NO. <b>LID-02</b>
-----------------------------	------------------------------------	----------------------	-----------------------	-----------------------------