

# *Accessible* Temporary Events

## A Planning Guide

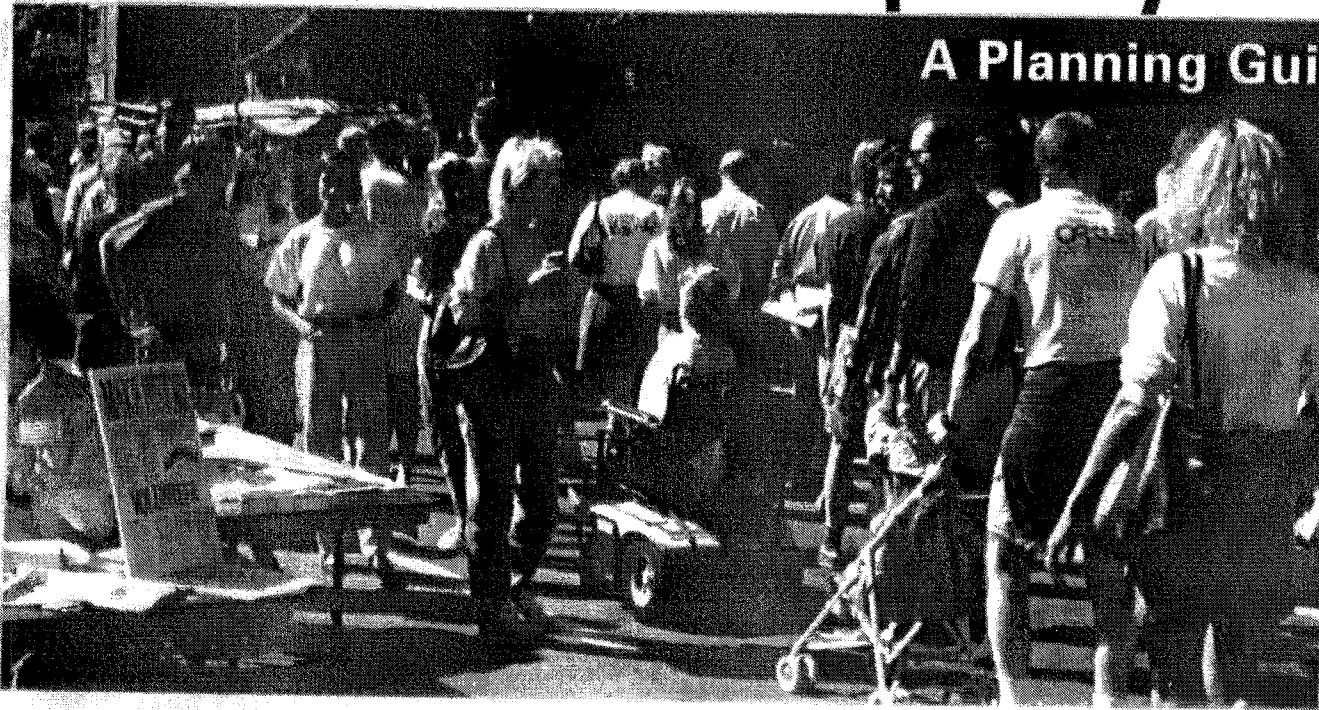

Provided by  
Pacific ADA & IT Center  
555 12<sup>th</sup> Street - Suite 1030  
Oakland, Ca 94607  
Toll Free 1-800-949-4232 (Voice & TTY)  
URL: [www.pacitbac.org](http://www.pacitbac.org)

## **Disclaimer**

While the Department of Justice Disability Rights Section has reviewed the contents of this publication for consistency with the Americans with Disabilities Act (ADA), the ADA itself and the Department's ADA regulations and Technical Assistance Manuals should be consulted for further, more specific guidance. The statements and conclusions contained in this publication are those of The Center for Universal Design and do not necessarily reflect the views of the Department of Justice. The Center for Universal Design has made every effort to verify the accuracy and

appropriateness of the document's content so that it may be regarded as an accurate resource. Yet, the information only is advisory and the guidance provided is not legally binding. While the publication does refer to specific requirements from the ADA Standards for Accessible Design (the Standards), it is not intended to supersede or supplant either the ADA or the ADA Standards. Readers are advised to refer to the ADA, and remember, no guarantee is offered or implied for the completeness of the information provided in this document.

# *Accessible Temporary Events*

## **A Planning Guide**

- >> **Produced by The Center for Universal Design,  
College of Design, North Carolina State University**
- >> **for the Southeast Disability and Business Technical  
Assistance Center under a grant from the National  
Institute on Disability and Rehabilitation Research**

## **CREDITS**

**Project Director:** Ronald L. Mace (1941-1998)

**Project Manager:** Rex J. Pace

**Authorship:** Leslie C. Young, Rex J. Pace  
**Contributing:** Ronald L. Mace, Karen Olander

**Editor:** Leslie C. Young

**Architectural Design  
and Conceptual Illustration:** Rex J. Pace, Ronald L. Mace, Leslie C. Young

**Graphic Design  
and Production:** Robert R. Rock, Jay Hess

**Illustration:** Rex J. Pace, Mark A. Pace, Charles D. Faust,  
Danny R. Vinson, Robert Graham, Donald A. Iddings

# TABLE OF CONTENTS

V	INTRODUCTION	
7	CHAPTER 1	Overview: <hr/> <b><i>Disability Awareness and Nondiscrimination</i></b>
15	CHAPTER 2	<b><i>Advanced Planning</i></b>
31	CHAPTER 3	Access to the Site: <hr/> <b><i>Getting There</i></b>
45	CHAPTER 4	Participating in the Event: <hr/> <b><i>Getting Around and Taking Part</i></b>
87	CHAPTER 5	<b>Service and Support Facilities</b>
99	CHAPTER 6	<b>Resources</b>

## **Dedication**

This book, originally conceived and initiated while he was still alive, is dedicated to Ronald L. Mace, FAIA. It is an attempt to bridge the legal requirements of the ADA with the more far-reaching concept of universal design. A concept Ron himself coined and passionately promoted, universal design is a belief that good design addresses the needs of all people, regardless of their age or cognitive or physical adaptability or status in life. Ron influenced this book while he was alive and, through others, his mission continues still—a vision of a universal environment that offers us all the opportunity to excel, allowing each of us to develop to our fullest potential.

## **Acknowledgements**

Like many projects that start as a seed in someone's mind, this project germinated and flourished out of conversations between Jim Bostrom (then at Barrier Free Enviroments, Inc.) and Shelley Kaplan. We are thankful to Jim for proposing the topic and indebted to Shelley for her direction and insight, remaining ever supportive that the project would be finished. We also are greatly appreciative that NIDRR and David Esquith provided ongoing support by allowing us to continue work on this project.

We also thankfully acknowledge the additional support and funding that brought this publication to completion provided by the Pacific Disability and Business Technical Assistance Center and it's Director Erica Jones, the Rocky Mountain Disability and Business Technical Assistance Center and it's Director Joyce Hume, and the Great Lakes Disability and Business Technical Assistance Center and it's Director Robin Jones.

We extend appreciation to the Department of Justice staff, most notably Ellen Harland and Ruth Lusher, who gave us guidance and council in the latter stages of the publication. Also, thanks go to The Center for Universal Design project staff who never gave up the possibility that this publication would one day be finished.

# INTRODUCTION

Street festivals, craft fairs, music events, state and county fairs, regattas, air shows, cat and dog shows, sports tournaments, parades and political rallies, marathons, dances, and home shows are but a few of the many temporary events that take place every day in communities large and small throughout the nation. These events celebrate every aspect of the human spirit; representing the art, health, and vitality of our communities. They are environments where our physical and mental abilities, skills, and creativity are both challenged and demonstrated. They are a forum for expressions of cultural, ethnic, physical, religious, and professional diversity. They punctuate seasonal changes and stimulate business and politics.

Temporary events are critical to supporting a “sense of community.” As such an important part of and as a reflection of our communities, temporary events must encourage participation by all people.

This manual provides information to assist planners, managers, operators, building owners, and participants in making temporary events accessible to people with disabilities to the greatest extent possible. The manual recognizes that events are sometimes big with large operating budgets while others are small and have limited funds. Some are held in developed urban settings and others in make-do facilities or on rural sites. The advice provided contains suggestions to reflect such differences.

This manual is intended to help meet obligations of the Americans with Disabilities Act. In addition, it also offers both simple and more elaborate recommendations to assist those who can and will go beyond the minimum requirements of the law to create environments and events that are truly universally usable by all, regardless of age or level of ability or disability.

As a resource book for both those who are new to or already experienced with accessibility, it acquaints the reader with:

- **the value of making temporary events accessible;**
- **an overview of the law;**
- **planning strategies to help prevent discrimination;**
- **typical barriers encountered by people with disabilities, both in the built environment and in communication, and solutions for removal; and**
- **methods of locating and coordinating available resources to achieve accessibility.**

Implementing the strategies and solutions suggested in this manual should be seen as an integral part of making a temporary event responsive and relevant to the community as a whole. The Americans with Disabilities Act is part of our larger civil rights tradition which recognizes and celebrates diversity and strives to include all members of our society. More than anything else, it is this spirit that should be embraced.





# CHAPTER **ONE** | overview

## ***Disability Awareness and Nondiscrimination***

People with disabilities are people just like others, they have the same needs and desires. Their disabilities do not make them different or set them apart from others in any way. Anyone can be born with a disability, be in an accident or become ill and develop a disability, and everyone grows old and loses some abilities. Some people even note that this is the only minority that a person can join at any time. In fact, more than 20 percent of Americans aged 15 and over presently have some type of disability; the most common involving walking and lifting. At some point in their lifetime, 70 percent of all Americans will have either a temporary or permanent disability. In the broadest sense, most of us at some time in our lives will have a disabling condition of some type; it is the rare few who will not.

Not until fairly recently have the needs of people with disabilities been given adequate attention. The passage of the Americans with Disabilities Act (ADA) is another step in the process toward creating an environment where people with disabilities can move and function as freely in society as people who have no disability.

According to the “Statistical Report: The Status of People with Disabilities,” compiled by the President’s Committee on Employment of People with Disabilities, published in 1994:

- 48.9 million Americans are persons with disabilities;
- 32 million Americans are age 65 or over;
- 3.3 million Americans are 85 or older, and this number is projected to grow by 100%, to over 6 million, by 2010;
- 70% of all Americans will, at some time in their lives, have a temporary or permanent disability that makes stair climbing impossible;
- 8,000 people survive traumatic spinal cord injuries each year;
- 17 million Americans have serious hearing disabilities;
- 8.1 million Americans have vision disabilities;
- 27 million Americans have heart disease and reduced or limited mobility.

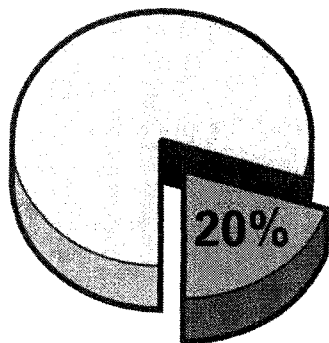

**More than 20% of Americans have a disability.**

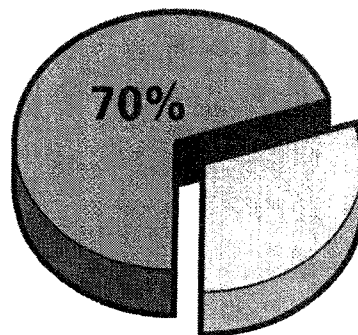

**70% of all Americans will have a disability at some point in their lives.**

## TYPES OF DISABILITIES

There are hundreds of different disabilities that can manifest themselves in varying degrees. While one person may have multiple disabilities, another may have a disability with symptoms that fluctuate. Sometimes, less obvious are people who have diseases of the heart or lungs, neurological diseases with resulting lack of coordination, arthritis, or rheumatism that may reduce physical stamina or cause pain. Reduction in overall ability is also experienced by many people as they age. People of extreme size or weight often need special accommodation as well.

In addition to people with permanent disabilities, there are others who may have a temporary condition that affects their usual abilities. Broken bones, illness, trauma, or surgery — all may affect a person's use of the built environment for a short time.

For purposes of the law, the ADA specifically defines disability. This definition has important legal implications that are reviewed later in this chapter (see “Definition of Disability” in “Overview of the ADA,” page 12). The following section provides a general overview of disabilities experienced by many people. Most architectural design standards are based on the needs of people defined by one of the following four general categories:

**1 | Mobility Disabilities** - This category includes people who use wheelchairs and those who use other mobility aids.

**Wheelchair Users** - People with severe mobility disabilities use either a power-driven or manually operated wheelchair or, the more recent development, the three- and four-wheeled cart or scooter to maneuver through the environment. People who use wheelchairs encounter some of the most obvious access problems

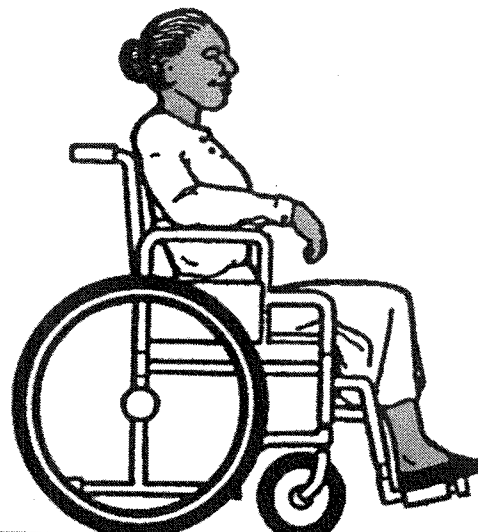

including maneuvering through narrow spaces, going up or down steep paths, moving over rough or uneven surfaces, making use of toilet and bathing facilities, reaching and seeing items placed at conventional heights, and negotiating steps or abrupt changes in level.

**Ambulatory Mobility Disabilities** - This category includes people who walk with difficulty or who have a disability that affects gait. People who use crutches, canes, walkers, braces, or artificial limbs to ambulate are also included in this category. Many people with mobility disabilities, as well as others, do not have full use of their arms or hands and may lack coordination. Activities that may be difficult for people with mobility disabilities include walking, climbing steps or slopes, standing for extended periods of time,

reaching and fine finger manipulation. Both people who use wheelchairs and those who use other types of mobility aids sometimes use service animals for assistance. For example, a specially trained dog may be used to retrieve items or even pull a wheelchair.

**2 | Visual Disabilities** - This category includes people with partial vision or total vision loss. Some people with a visual disability can distinguish light and dark, sharply contrasting colors, or large print, but cannot read small print, negotiate dimly lit spaces, or tolerate high glare. Many people who are blind depend upon their senses of touch and hearing to perceive their environment and communicate with others. Many use a cane or have a service animal to facilitate moving about. Some problems experienced by people with visual impairments include orientation, receiving written or graphic

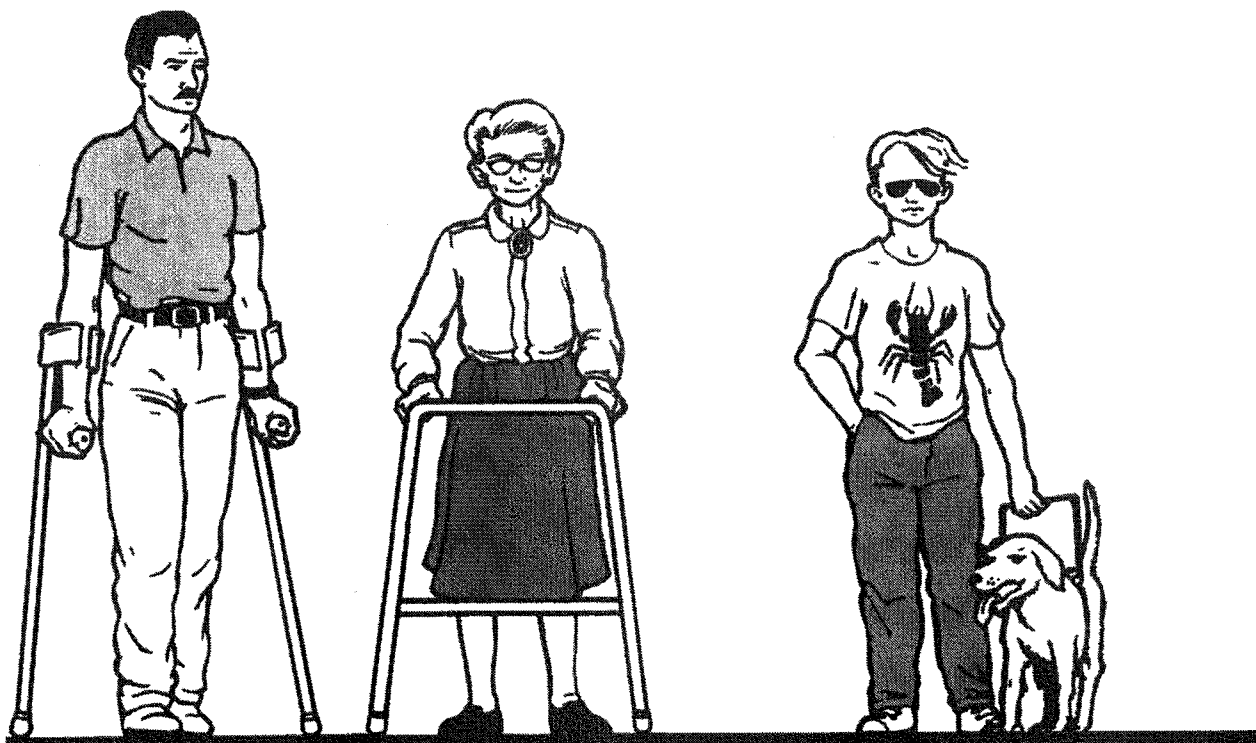

information, using controls that are not adequately labeled, and avoiding hazardous protruding objects which they cannot detect.

**3 | Hearing disabilities** - People in this category use a variety of methods to compensate for their inability to hear sound. Those with partial hearing may depend on hearing aids or lip reading. Some people who are totally deaf also use speech-reading but must be able to clearly see the face of the individual speaking. Others use a standard means of communication called sign language. Hearing people can learn sign language and can be interpreters. Some



people with hearing disabilities will use service animals to alert them to sounds. Problems for people with hearing impairments include communicating with many hearing people and using equipment that is exclusively auditory, such as telephones and fire alarms. Lack of sign language interpreters and inadequately trained interpreters also can be a problem.

**4 | Cognitive Disabilities and Other Hidden Conditions** - There are many

other disabling conditions which are not apparent from an individual's outward appearance. These usually involve cognitive and/or learning abilities and may affect understanding, communication, or behavior. People with these disabilities may have difficulty using facilities, particularly where the signage system is unclear or complicated. Seizure disorders are also another common hidden condition. In some individuals, environmental features such as lighting can activate seizures.

A hidden condition gaining greater awareness lately is a condition known as multiple chemical sensitivity. People with this condition experience a physical reaction that generally affects breathing when they come in contact with a chemical or combination of chemicals that may

be present in many buildings and consumer products.

These can include items such as lawn pesticides and herbicides, room deodorants, printing inks, and even colognes or perfumes.

Reactions can range from mild to life threatening.

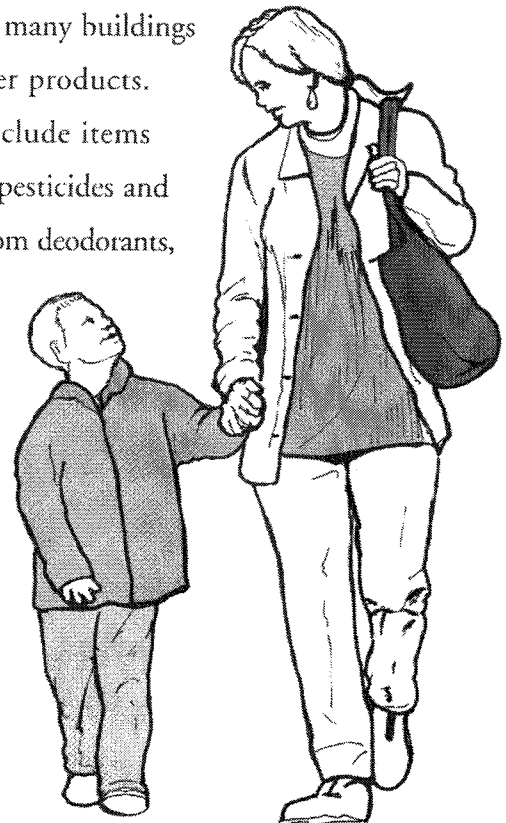

## OTHER LAWS AND CODES THAT MANDATE ACCESSIBILITY

While this publication primarily focuses on accessibility and the ADA as a guide, it is important to be aware of other disability legislation affecting temporary events. Over the past two and a half decades, several statutes have been enacted at various levels of government that promote access or prohibit discrimination against people with disabilities, both in the design of the built environment and in the manner in which programs are conducted. Regardless of overlapping requirements, the end result is intended to be the same — temporary events that include all members of the community.

### **The Architectural Barriers Act (1968) -**

This Act stipulates that most buildings, other than privately-owned residential facilities, constructed by or on behalf of, or leased by the United States, or buildings financed in whole or in part by the United States, must be physically accessible for people with disabilities.

### **Section 504 of the Rehabilitation Act (1973)**

- Under Section 504 of the Rehabilitation Act of 1973 as amended, no otherwise qualified individual with a disability may be discriminated against in any program or activity receiving federal financial assistance. Many of the concepts in this and the Architectural Barriers Act were incorporated into the ADA.

**State and Local Codes** - All states and many cities and counties have developed their own building codes for accessibility, usually based in whole or in part on the specifications contained in the major national design standards such as the Uniform Federal Accessibility Standards (UFAS) or those by the American National Standards Institute (ANSI). Many states also have nondiscrimination laws similar to the Americans with Disabilities Act. As such, it is important to remember that compliance with both federal law and state/local codes is required.



## OVERVIEW OF THE ADA

The Americans with Disabilities Act is a federal civil rights law that prohibits discrimination against qualified people with disabilities. Much of its language and spirit is derived from earlier nondiscrimination legislation regarding race, color, sex, national origin, age, and religion. The law guarantees access to the programs and services run by state and local governments and the goods and services offered by private businesses. It also provides for equal opportunities in the areas of employment, transportation, and telecommunications.

### Definition of Disability

The ADA has a broader definition of disability than the general functional limitations presented earlier. It includes not only actual physical and mental disabilities, but also limitations caused by the attitudes many feel and express toward people who are perceived as being disabled. There are three categories of individuals protected under the ADA:

**1** | People with a disability, physical or mental impairment that significantly limits a major life activity. Examples of major life activities include caring for one's self, performing manual tasks, walking, seeing, hearing, speaking, learning, and working.

**2** | People with a history of a disability, someone who at some time in life had a disability that significantly limited a major life activity for a period of time.

**3** | People regarded by others as having a disability, though a major life activity may not be limited. For example, a person with severe facial scarring.

### Structure of the Law

The ADA is comprised of five sections or "titles" that cover different aspects of non-discrimination:

- **Title I** covers private sector employment
- **Title II** covers state and local government programs, activities, services, and employment
- **Title III** covers private businesses and nonprofit service organizations (public accommodations and commercial facilities)
- **Title IV** covers telecommunications
- **Title V** covers certain miscellaneous legal and procedural aspects of the law.

Titles I, II, and III are the most critical to someone planning a temporary event. These titles cover practices regarding staff as well as the degree to which physical and communications access is provided.

The focus of this guide is on events open to the general public where broad and comprehensive modifications and/or accommodations are required under Titles II and III. However, there are often similar activities conducted exclusively for the enjoyment of their employees by state and local governments or private businesses. These “employee only” events are covered by Title I of the ADA where only the needs of a particular employee with a disability must be met.

Temporary events are unusual in that they are often a blend of both private and public sectors. For example, a local symphony orchestra that relies on both state funding and private revenues may hold a special Fourth of July concert and fireworks display on the campus of a private college and use city police for parking and crowd control. As such, the event is covered by more than one title of the ADA.

Many private clubs and religious organizations are exempt from providing access to the public. However, if a private club sponsors an event such as a golf tournament that is open to the public, it must comply with the ADA.

### **The ADA Standards for Accessible Design**

The ADA recognizes inaccessible buildings as one form of discrimination and addresses this discrimination by specifying how buildings and facilities must be designed, modified, and constructed to be accessible. This includes temporary structures that are extensively used by or are essential for the public use at an event.

Initially, guidelines, known as the ADA Accessibility Guidelines or ADAAG, were developed by the Architectural and Transportation Barriers Compliance Board (the Access Board) from earlier national accessibility design standards. The ADAAG with minor amendments became the ADA Standards for Accessible Design (the Standards) as part of the Title III final rule issued by the U.S. Department of Justice. The Standards are enforceable, but they are often referred to as the “ADAAG” because of the acronym’s broad public recognition.

The Standards do not provide direct solutions to all of the various barriers that may be encountered at a temporary event, but give basic design criteria useful in resolving most problems. The design recommendations and solutions presented in this guide are based on the Standards.

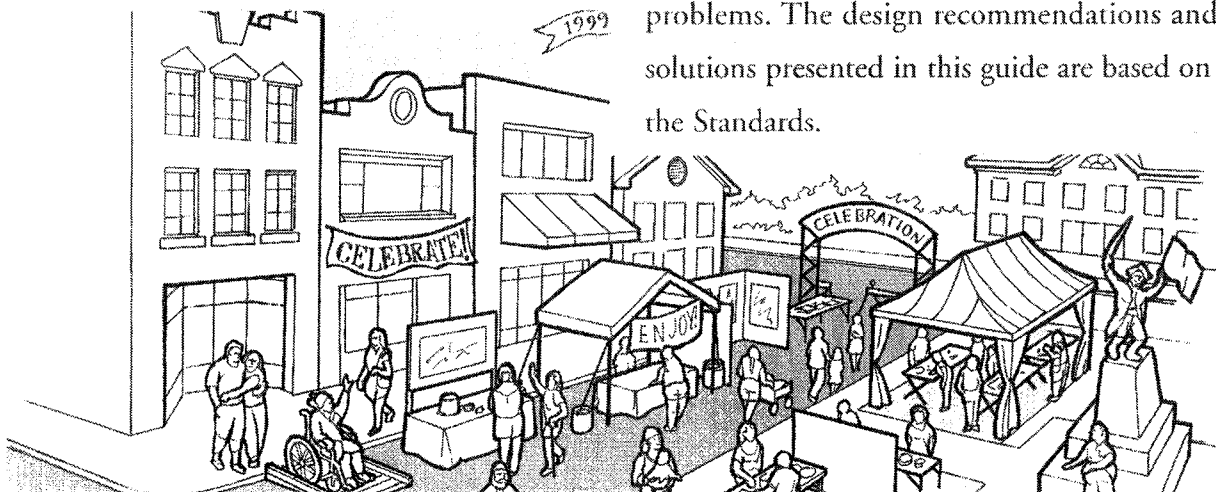





# CHAPTER **TWO** | *Advanced Planning*

## OVERALL STRATEGY

Inclusion of participants with disabilities in any temporary event is made easier through pre-planning — especially when it is a first accessibility effort by an organization. As part of advanced planning, it is helpful to know:

- why planning for accessibility from the beginning is important;
- how to manage diverse accessibility factors;
- how to select a successful site;
- how to be prepared for participants/performers with disabilities;
- how to let participants know the event is accessible; and
- that people with disabilities are a valuable resource and should be consulted in planning for and conducting the event.

Awareness of disability-related issues is increasing. Many people now understand to what extent site and building features can either impede or promote access. The architectural components that affect people with mobility disabilities have long been addressed in public and private design standards that deal with accessibility.

With the passage of the ADA, new emphasis has been placed on removing barriers to people with sensory disabilities, i.e., people with speech, hearing, or seeing disabilities. Of equal weight as physical barriers, communication barriers prevent many who would otherwise be participants from being able to comprehend or respond to an event or performance.

In the language of the ADA, people with disabilities must be able to obtain or enjoy “the same goods, services, and benefits” that are provided to other members of the public. The following overview is a list of activities and services that are often offered as part of a temporary event. If such opportunities are offered to others, then participants with disabilities also must be able to:

- obtain information and directions prior to the event;
- arrive at the site via private automobile, taxi, or public transportation;
- find and use accessible parking;
- get from accessible parking to entrances;
- obtain additional information and directions on site;
- move around the site as needed to attend all activities and functions offered;
- attend performances, participate in activities, and enter exhibits;
- experience and enjoy activities of the event, even if the participant’s disability affects their ability to communicate;
- select and purchase items at concessions and participate in activities offered by vendors;
- use public toilet rooms, telephones, water fountains and other typical common public amenities such as shelter from sun and rain; and
- have access to first aid.

### **Plan Early and Review Often**

Planning for accessibility from the beginning dramatically affects the success of the event—creating an event that is more enjoyable for all participants, including people with disabilities. Efforts to provide access after critical decisions have been made, such as site selection, often generate burdensome expenditures of time and money and may result in substandard “add-on” solutions that may be more costly or less effective than necessary. Once initiated, the entire process, from planning to actually conducting the temporary event, must be reviewed often to ensure that accessibility is provided and maintained.

### **Managing Diverse Issues**

An extremely effective strategy to managing accessibility efforts is to designate a person for this task who is committed and knowledgeable or can be educated quickly. This “accessibility coordinator” should be attentive to accessibility issues through all phases of the temporary event—from overseeing the implementation of planning decisions to assisting with locating resources, and being sure that accessibility concerns are attended to during the actual event. This role is especially important for larger events where many diverse elements must be managed.

The person designated to oversee the accessibility of the event should not be expected to conduct all activities related to access, but be responsible for delegating duties and tracking

their implementation. Numerous resources are available for the “accessibility coordinator” to draw upon, including individuals with disabilities, national organizations that serve people with disabilities, accessibility consultants, and federal and regional information offices (see Chapter 6: “Resources,” page 99).

### **Resources for Planning**

**Advisory Committees.** Early in the planning process, consider establishing contact with people with various disabilities. While having a disability does not make one an expert on all issues, a knowledgeable person can help locate resources or services and offer insightful advice. It can be particularly helpful to have people with disabilities involved in the selection of a site.

In some instances, especially for large events, it may be appropriate to establish an advisory committee. If members of the committee have a range of disabilities and experience, individuals can help solve problems related to their disability. Since access issues often have an architectural component, include people who also have design experience.

**Disability Organizations.** Consider contacting both local and national disability groups and organizations. These organizations are excellent resources for information and advice. Depending on the group or organization, they may be good sources either for providing or finding services: from sign language interpreters to where to rent equipment such as TTYs or portable ramps.

Should you require technical assistance regarding the ADA Standards, resources include the Department of Justice and the Disability and Business Technical Assistance Centers (DBTACs). The DBTACs are funded by the National Institute on Disability and Rehabilitation Research to provide information, training, and technical assistance to businesses and agencies covered by the ADA and to people with disabilities who have rights under the Act. The US Department of Justice answers questions about the ADA and provides free publications by mail and fax. See the section “Government Resources” in Chapter 6: “Resources” on page 100 for a listing and contact information for the ten regional centers and for the Department of Justice’s ADA Information Line.

#### ***Architectural Accessibility Consultants.***

Accessibility consultants also are a source of advice and information, particularly for compliance and solutions to specific architectural barriers. If funds are available, hire a firm or an individual with both accessibility and architectural design experience. For more information on disability groups and organizations, see Chapter 6: “Resources.”

## **SITE SELECTION**

Accessibility is but one of many issues that influence the selection of a site for a future temporary event. However, which site is selected has the greatest overall impact on accessibility to the event. Inaccessible architectural features may be among the most difficult barriers to remove.

Most facilities were constructed before the passage of the ADA, and perhaps even before state or local laws required accessibility. It is very likely that only a partially accessible site can be found. Although stating the obvious, if more than one site is available, it is recommended that the most accessible site be chosen—even partially accessible sites can be improved with ingenuity and forethought.

### **The Importance of an Accessible Route**

Critical to the successful use of a site is the presence and extent of an accessible route. It is the central component of accessibility that unites separate spaces, elements, and features into a usable whole. This single continuous accessible pedestrian path should be wide, smooth, as level as possible, without low or overhanging hazards or obstructions, and not require the use of stairs. See the section “Accessible Route” in Chapter 4: “Participating in the Event” on page 46 for additional discussion of accessible route.

Accessibility will only go as far as the accessible route goes. Since the presence of an accessible route is the cumulative result of many factors, a complete review of the site is necessary to determine its adequacy. Walk the site and lay out the accessible route participants with disabilities would be likely to use. Emphasis should be placed on having people with disabilities use the same route as the rest of the participants and not require them to travel unusually long distances to reach a destination.

**Evaluating the Site**

As a general rule, recently constructed sites are more accessible than older ones. Be aware that many facility owners and operators may not have the experience or knowledge to determine the level of accessibility on their sites. If they have never received any complaints, they may mistakenly assume that no problems exist. Regardless of the age of the facility, or the opinions of the owners or management, any site under consideration should be inspected to make an accurate assessment of its level of accessibility.

Care must be taken to examine all areas of the site you expect to use. Details as seemingly insignificant as a doorway that is two inches too

narrow, or a threshold or step no more than 1/2-inch high, may severely hamper some people from moving about safely and independently.

There are several checklists available to help you assess an event site for existing barriers to people with disabilities. These checklists do not specifically address building and site requirements as related to a temporary event; however, they can help in determining the degree to which an existing facility complies with the ADA and to what extent modifications may be needed. A list of some of the available checklists is provided in Chapter 6: "Resources" in the section "Selected Publications," page 99.

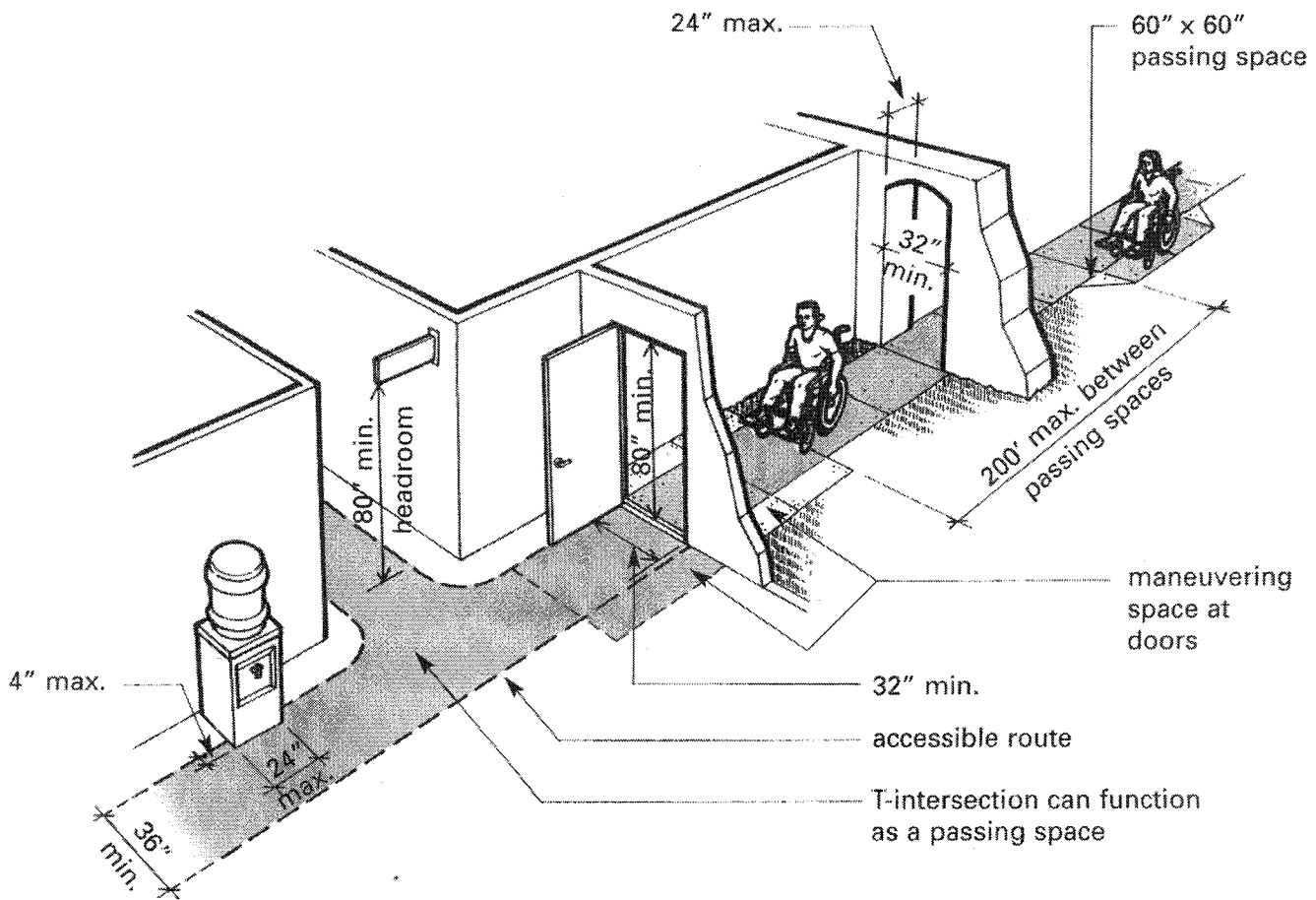

**Basic Features of an Accessible Route**

## GETTING STARTED

Event organizers generally have more direct control over the accessibility of the event's activities than over the site. If site modifications are required, they may take some time to accomplish—planning for these must be tackled early. Other issues also must be addressed, from modifying standard operating procedures in order to accommodate people with disabilities, to staff awareness and cautioning vendors to avoid oversights. Marketing and promotional materials should be available in a variety of formats, and temporary structures brought onto the site, such as tents, stages, and portable toilets, need to be designed with access in mind.

### Modifications to a Site

There are both financial and legal incentives for owners to remove barriers. As the number of people with disabilities increases, particularly among the expanding population of older Americans, there is increased demand for accessible sites. Additionally, since the passage of the ADA, event organizers are now giving accessibility a higher priority.

Facility owners and managers must meet the ADA's legal requirements for access and should have already taken action to remove barriers. All privately-owned businesses that serve as places of public accommodation (such as hotels, restaurants, theaters, museums, auditoriums, convention centers, shopping centers, parks, zoos, or amusement parks) are considered Title III entities under the ADA and are expected to

remove barriers when it is "readily achievable" to do so. Barriers that are considered readily achievable to remove are those that can be changed easily and carried out with little or no expense. See the following list of modifications included in the regulations to the ADA.

### Barrier Removal Measures that May Be Readily Achievable

- installing ramps
- making curb cuts in sidewalks and at entrances
- repositioning shelves
- rearranging tables, chairs, vending machines, display racks, and other furniture
- repositioning telephones
- adding raised markings on elevator control buttons
- installing flashing alarm lights
- widening doors
- installing offset hinges to widen doorways
- eliminating a turnstile or providing an alternative accessible path
- installing accessible door hardware
- installing grab bars in toilet stalls
- rearranging toilet partitions to increase maneuvering space
- insulating lavatory pipes under sinks to prevent burns
- installing a raised toilet seat
- installing a full-length bathroom mirror
- repositioning the paper towel dispenser in a bathroom
- creating designated accessible parking spaces
- installing an accessible paper cup dispenser at an existing inaccessible water fountain
- removing high pile, low density carpeting
- installing vehicle hand controls.

Bear in mind that the expectation for what is considered “readily achievable” is based on a company’s size, financial condition and the existing site conditions. What might be appropriate for a large multi-national investment company is very different than the expectation for a one-day craft show or an antique show sponsored by a glass collectors group. Owners of facilities can be reminded of these obligations and how modifications needed for a temporary event can help meet their ADA obligations.

Services and programs provided by state or local governments, and government facilities, considered Title II entities, must be accessible. There is some flexibility when trying to achieve accessibility because programs and services can be relocated to an accessible site or brought to a person needing the service or program. Often, in smaller communities, there may be no accessible facility available, so modifications for accessibility must be made to the existing facility.

Where required when providing program access, architectural modifications must be implemented unless it would cause an “undue

Unlike private entities under Title III, public entities are not required to remove barriers from each facility, even if removal is readily achievable. A public entity must make its “programs” accessible. Physical changes to a building are required only when there is no other feasible way to make the program accessible.

In contrast, barriers must be removed from places of public accommodation under Title III where such removal is “readily achievable,” without regard to whether the public accommodations’ services can be made accessible through other methods.

*From the Department of Justice Title III Technical Assistance Manual (1993) - and Supplements, Item II-5.2000.*

When there is no accessible parking, an existing space can be temporarily used as an access aisle to make the spaces on either side of the aisle accessible.

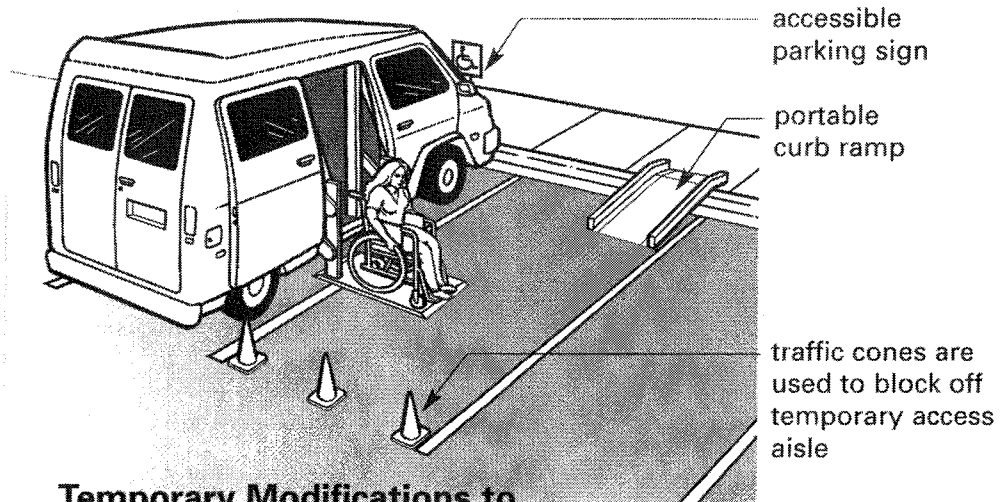

**Temporary Modifications to Permanent Site Feature**

burden” to do so, or, in other words, is excessively difficult or expensive. Here again, modifications needed for an event can help the government entity meet the long-term obligations under the ADA. Once barriers to access have been identified, negotiate with the owners/managers of the facility for removal of barriers. It may be possible to tie the completion of these changes to your contract agreement. An accessible site may very well give the lessors/owners a competitive edge over those with less accessible facilities.

### **Temporary Modifications to Permanent Site Features**

When permanent changes to a site cannot be made and the entire event or specific activities of the event cannot be relocated, temporary modifications must be made. While temporary changes often are not as effective and usable as permanent ones, they do show a commitment on the part of event operators to accommodate all people. Temporary modifications, as much as possible, should meet the technical design requirements of the ADA Standards.

Recognizing that this is not always possible, issues of safety and usefulness must always be examined when installing temporary modifications for accessibility.

It is possible to purchase, rent, or fabricate many of the necessary features, such as ramps, assistive listening systems, or signs. However, discretion must be used. For example, it may be easier to reroute a path around a long flight of stairs rather than constructing an expensive

ramp or renting a portable lift. Suggestions and strategies for temporary modifications are presented in the following chapters.

### **Temporary Structures and Features**

Structures, such as booths, tents, bleachers, stages, or similar features, set up for the event, are integral parts of the activities offered and should be usable by people with disabilities. Critical services such as information and first aid booths, as well as portable toilets must not be overlooked. While not containing an actual “activity,” these are integral to the health, safety, and enjoyment of all participants. When fabricating or selecting temporary structures, remember to factor in the accessibility requirements.

Likewise, portable exhibits and performing areas where entry for participants is intended should be designed to be accessible. While it may not be possible to make all exhibits accessible (for example, experiential sculptures that one enters), an attempt should be made to make a portion of the exhibit accessible or, at the very

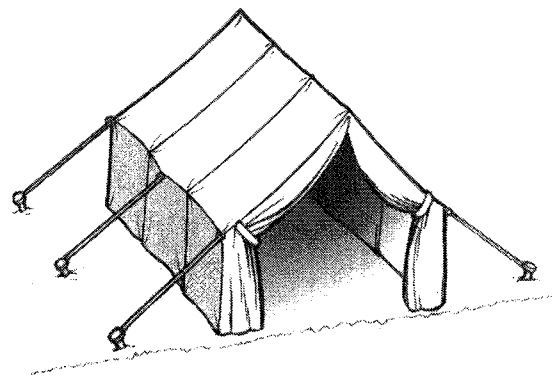

**Tents are Common Temporary Structures**

least, allow participants with disabilities to get close to and touch the sculpture. For more detail see Chapter 4: "Participating in the Event," page 45.

### **Modifying Policies and Procedures**

The way temporary events typically have been run may no longer be relied upon. Policies or procedures must not inhibit access. Some flexibility is necessary when accommodating people with disabilities, whether needs are specific, for performers, or general, for the public. However, modifications to policies and procedures and the addition of services to accommodate people with disabilities are not required to the extent that they would "fundamentally alter the nature of the event" or pose a safety hazard. In other words, accommodations for people with disabilities need not change the concept of the event so that it no longer represents the type of event you intended to offer. Nor should providing accessibility exhaust financial limits of the organization attempting to conduct the event.

Attendants and service animals, necessities for some people with disabilities, present a good example of when policies and procedures must be modified. Attendants should be allowed to accompany a person with a disability as needed, but this does not require a two for one ticket pricing policy. Service animals are not pets, but act as a guide for people with vision disabilities, alert persons with hearing disabilities of sounds, help pull a wheelchair or provide other assistance. They must be allowed to accompany an individual

into the event unless it would constitute a fundamental alteration of a program.

**Service animal means any guide dog, signal dog, or other animal individually trained to work or perform tasks for the benefit of an individual with a disability, including, but not limited to, guiding individuals with impaired vision, alerting individuals with impaired hearing to intruders or sounds, pulling a wheelchair, or fetching specified items.**

### **Preparing for Communication Access**

In addition to the physical barriers of the built environment, communication barriers also must be considered and removed as much as possible to allow people with disabilities to participate in activities and communicate with staff and other participants. Electronic/mechanical devices, such as assistive listening devices, and trained personnel, such as sign language interpreters assist

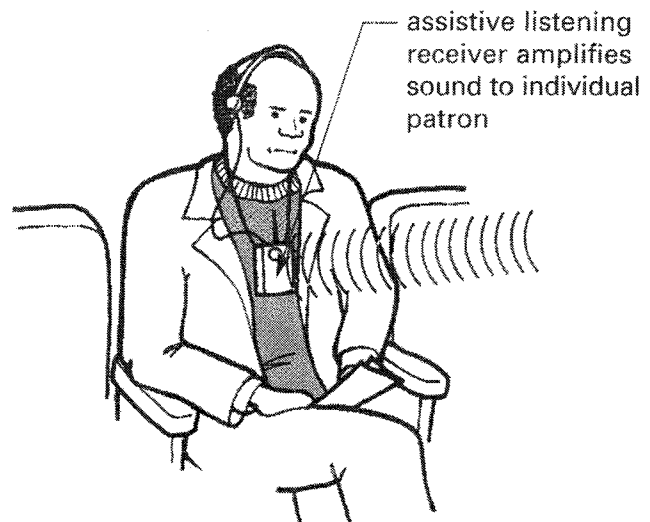

assistive listening receiver amplifies sound to individual patron

**Example of a Communication Aid**



people with hearing disabilities, while large print text, Braille and material recorded onto audio cassette assist people with vision disabilities.

Where casual information is going to be exchanged, such as at a booth selling a local artist's photographs, use of pencil and paper is probably sufficient. However, a key performance of the temporary event should have at least some scheduled performances accompanied by sign language interpretation. (Programs or handouts at the event should indicate whom to contact for interpreters or which performances or activities will be interpreted. See page 25, "Accessibility Symbols.") Another method to employ for musical performances is to include a large screen with song lyrics superimposed. Many people who are deaf or hard of hearing still feel the reverberation of the bass range in music.

Alternate formats also may be needed to convey the content of speeches, performances, or exhibits. For example, a text description of an opera can be made available for people with partial hearing loss. For people with vision disabilities, an audio description of a slide show can be made available on cassette or the speaker may simply describe the slides while presenting. It may be unrealistic to interpret or otherwise describe all activities at an event. In such instances, the main events and most representative examples of experiences offered should be made accessible to everyone to convey key points and themes of the event. For more detail on communications access refer to Chapter 4: "Participating in the Event," page 45.

## **Coaching Vendors**

Another important component of many temporary events is vendors selling food or other merchandise or operating activities such as games or contests. Ideally, booths, displays, or carts used should be accessible. However, for example, concession carts at local fairs often are owned by an individual and remain on a permanent chassis required for transport. If existing designs cannot be modified to be accessible, then the method of providing the service must be altered.

Work with vendors to ensure that people with disabilities will have comparable access to food, drinks, merchandise, or services offered. Vendors should be advised to offer additional assistance so people with disabilities can participate equally, i.e., vendors must be willing to provide the same service offered to everyone else. This generally involves only simple or minor procedural changes, such as taking items to an interested individual from an inaccessible area. Remember that such services are not appropriate for all event participants, but are a

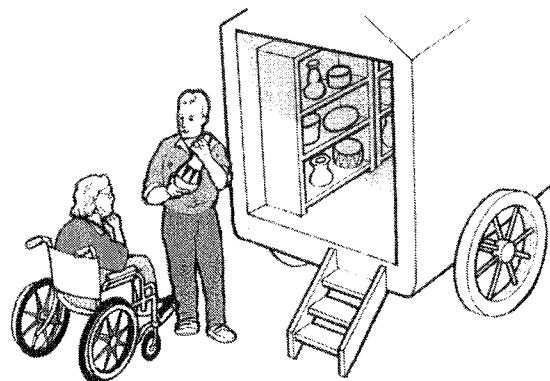

**Vendor Must Accommodate Customers with Disabilities**

necessity for some people with a disability to allow them to evaluate and select merchandise or to participate in an activity offered. For more detail, see Chapter 4: “Participating in the Event,” page 45.

### **Preparing Staff and Volunteers**

All staff and volunteers should have a basic awareness of and sensitivity to disability issues. Make it clear to staff and volunteers that people with disabilities expect to be treated like all other event participants.

**Appropriate Staff Advice.** View an individual in terms of the whole person and not just the disability. Avoid being anxious or overly protective; people will let you know what they need. Be aware that many people will need extra time to move, speak, perform a task, or participate in an activity. The behavior of some people with developmental or cognitive disabilities may be unsettling to people unfamiliar with these disabilities. There is no need for fear and, as with others, respect and patience is expected. In other words, provide good customer service to everyone.

Make sure that staff and volunteers are aware and know the location or availability of accessible features in their respective areas. This includes knowledge of such features, spaces, and services such as toilet rooms, telephones, TTYs, ramps, or which performance is accompanied by a sign language interpreter.

### **Accommodating Performers with Disabilities**

Don't forget you may have speakers or performers with disabilities. If performing or stage areas are not to be used by the public and have not already been made accessible, then some modifications must be made. Accessibility to low stages and speaker's platforms is shown on page 76 in Chapter 4: “Participating in the Event”. High stages are more difficult to make accessible.

Carrying a person with a disability up steps to the performance area is never acceptable—it is dangerous to all involved. If the stage is very high, portable lifts may be rented. Where an existing ramp is steeper than specified in the ADA Standards and it is not readily achievable to modify, people traversing the ramp should be assisted by several competent trained individuals to prevent falls and mishaps.

If your presenters have a hearing or visual disability, they usually can help you decide what would be the most effective means to get their message across to the audience. There are sign

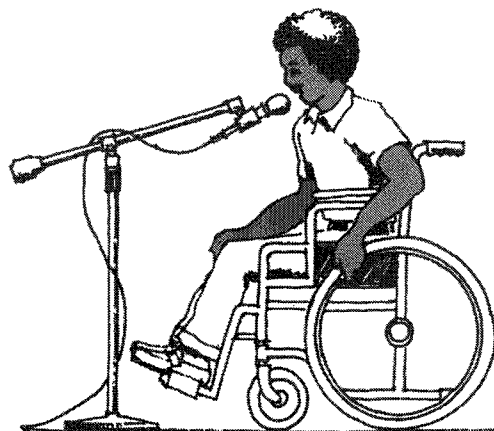

**Performers or Speakers May Have Disabilities**

language interpreters who specialize in performance interpretation and actually are like actors themselves.

## PUBLICITY OF THE EVENT

Many people with disabilities still assume that most temporary events will not be accessible. Thus, it is important to provide statements regarding access on all publicity and informational material. Declarative low-key statements affirming nondiscrimination are an important part of your commitment to providing accessibility. It also may be necessary to provide user information on accessible features such as parking or where to obtain information available in other formats.

### Accessibility Symbols

Publicity materials should be accompanied by symbols of accessibility when the event is fully accessible. The most recognized symbol is that of the wheelchair. However, its use must be applied carefully. If it is used to indicate that the entire event is accessible, and only certain performances include, for example, sign language interpretation, then those performances should be so designated in a program or notice. Other accessibility symbols, such as the International Symbol of Access for Hearing Loss and the TTY symbol can be included as appropriate on brochures, handouts, and publicity pieces.

### Publicity Options

Not all people receive information the same

way. Print materials are generally usable for the person who can see and read, where as other people must rely exclusively on aurally presented information. When announcements publicizing an event are planned it is important to reach all potential participants. New venues may have to be considered to guarantee that people with disabilities are notified of an event. Although not directly specified by the ADA, access to information

A sample low-key statement

**This meeting is accessible to all people.**

Never use the term accessible to the handicapped



**International symbol of accessibility**  
(light on dark-dark on light)



**International symbol of access for hearing loss**

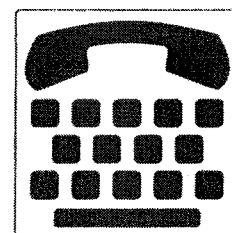

**International TTY symbol**



**volume control telephone**

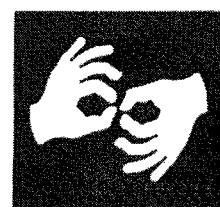

**sign language interpreted**

## Accessibility Symbols

about an event ensures that people with disabilities will have an opportunity to participate. If possible, present all event and publicity announcements in a variety of both print and broadcast media.

Consider contacting local disability groups and organizations to publicize accessible activities, programs, or services offered at your event. These groups can be effective in getting the word out to members of the community who are not reached by traditional media. As some have scheduled releases for newsletters, etc., these organizations should be notified as early as possible to allow ample time to include the information.

**Print Media.** Flyers, brochures, and newspaper or magazine advertisements should be presented in typefaces that are large, high contrast, and easy to read (simple serif or sans serif). This not only increases legibility for people with limited vision, but is just plain easier for everyone and especially for people with hearing disabilities who get most information through sight, see “Usable Type” later in this chapter on page 28.

While space limitations for an advertisement or document may not allow all information to be in large print type, key concepts, dates, and telephone numbers should be presented using the above general type characteristics. Additionally, keying important statements with the appropriate accessibility symbol (e.g., interpreter symbol for a lecture) will highlight their importance and help people who have difficulty reading.

**Broadcast Media.** Television and radio may reach many people with disabilities in a way print media cannot, particularly people with visual or cognitive disabilities. Due to the brief nature of broadcast media, allow for sufficient follow-up to inquiries about access to the event. Broadcast media may be beyond the scope or budget of many events; however, depending upon the nature of the event, there still may be opportunities for public service announcements, cable access channels, or donated airtime.

Although radio can be used to communicate to large numbers of people, it is not effective for people with hearing disabilities. On the other hand, television can be an ideal way to publicize since it has both audio and visual features. Captioning (a form of subtitles) can be added to make the audio portion of the message visually communicated. In addition, similar to some televised news reports, a sign language interpreter can be superimposed in the corner of the screen.

**Computer Bulletin Boards.** While not as pervasive as print or broadcast media, but gaining much popularity, computer bulletin boards are another source of publicity that can be used to reach many people with disabilities. It may even be possible to add an audio component to the visual information offered.

### **Responding to Inquiries**

Responding to questions regarding accessibility is critical, particularly when publicity cannot provide complete details. If the event is going to be a large one and the accessibility complicated,

it may be best to have a designated person with a thorough knowledge of all accessibility services available to respond to questions. Be prepared to offer more detailed information such as availability of interpreters or audio descriptions and location of accessible entrances and toilet facilities.

The capacity to communicate over the telephone with people who have hearing or speech disabilities is very important. Telecommunication devices for people with sensory disabilities, known as TDDs or TTYs, can be used with traditional telephone handsets to type messages back and forth. Publicity material should indicate if it is possible to communicate in this manner. TTYs can be rented in some locations. Software also is available which allows some computers to work as TTYs.

Another option is the Telecommunication Relay Service offered by local telephone companies and required by the ADA. Operators at the relay service act as an intermediary between the speaking user and the TTY user.

This service is not as efficient or effective as TTY-to-TTY systems and may not be appropriate for particularly large events. When providing phone numbers in ads or other media where a TDD/TTY device is not available, it is recommended

that a reference to the use of the local relay service should be made for TDD/TTY users in obtaining information.

### USABLE TYPE

Most temporary events rely heavily on printed information, both as part of the advertising campaign and during the event itself. The design of type and how it is applied should be considered, among other avenues, for newspaper ads, fliers, event programs, schedules, maps, and exhibit descriptions. While the ADA does not specifically address the design of such printed materials, following are some general parameters that will help you design printed pieces to make them more usable to the general population as well as people with vision disabilities.

People with limited vision and those with some cognitive disabilities need printed material that is easy to read, especially if the information is



Portable TTY

## CHAPTER 2

to be read quickly and in less than ideal circumstances, such as while walking, at night, or at a distance. Type should be simple and contrast highly with the background. When graphics are included, they should be clear and not overprinted onto type.

The following type parameters should be followed when preparing most printed materials necessary for a temporary event. This printed material is distinguished from permanent building signs and temporary signs which are addressed in Chapter 5: "Participating in the Event" in the section "Getting Around: Signage," see page 59. To make printed materials legible for the largest percentage of the population, they should be prepared:

### With content that

- uses clear, non-technical English in the active voice.
- has limited sentence length of fewer than 25 words. If possible, keep each sentence to one thought only.
- when in the form of instructional text, it is formatted in either a bulleted or numbered list, usually limited to three or four items per list.

### With type design that

- uses sans-serif or simple serif type faces. Limit the number of typeface varieties to two or three. Examples of sans serif typefaces include Helvetica, Univers, Arial, and Futura. Suggested simple serif

typefaces include New Century Schoolbook and Palatino.

- uses bold face type for single-page fliers that are posted, for example, on a bulletin board.
- is presented in 16-point type size when possible so it is read easily by most participants.

### Examples of Sans-serif Typefaces

---

Helvetica

Univers

### Examples of Simple Serif Typefaces

---

**New Century  
Schoolbook**

Palatino

### Do Not Use the Following Type Styles

---

*Script type*

condensed type

**extended type**

light type

*ornate italic type*

- uses line spaces of one and one-half spaces or is double spaced (in typesetter's language: line space should be about 20 percent larger than the type size. For example, if the type size is 14 points, the leading should be at least 17 to 18 points.)
- uses lower case letters with initial capitals.
- avoids underlining except in headings.
- justifies text on left side only. Type that is justified both left and right hinders legibility because it introduces awkward spaces between words that people do not recognize, making text more difficult to read.
- where narrow columns of text are used, provides at least an inch of white space between columns.
- are opaque with the use of non-glossy colors and materials. A medium with a matte or other non-glare finish should be used for both the background and the text.

The planner should strive to produce all printed materials in at least 14 or 18-point type to be readable both by people with low vision and by sighted people. This can be accomplished by using a photocopier to enlarge existing type if this provides good ink coverage or by using a computer/word processor. Even the most rudimentary computers often have the capability of generating type in different fonts, sizes, and weights.

**With type and background that**

- contrast with each other. The Standards recommend that characters contrast with the background by at least 70 percent. Avoid, for example, combinations such as yellow on gray. In dimly lighted spaces, white type on a black background is slightly more legible than black type on a white background. But the type size under these circumstances must be at least 12 points or larger. Dark type on a light background works marginally better than light on dark for large type such as headlines.

**16-point type**  
**16-point bold type**

**ALL CAPS ARE HARD TO  
READ IN CONTINUOUS TEXT.**

**Use of Initial Caps in  
Headlines is Preferred.**





# CHAPTER **THREE** | GETTING THERE *Access to the Site*

Participants arrive at an event singly, accompanied by friends / family, or in groups. They use personal cars and vans, public buses, taxis, or other modes of transit such as rail. All visitors, including people with disabilities, arrive at the site using these same modes of transportation and must be able to move about with safety and ease.

Owing to the wide range of possible site configurations and available resources, an event planner may have to use some ingenuity to achieve suitable access. However, there are basic features

of the site that must provide a minimum level of access for participants with disabilities. The design and location of accessible parking spaces, transit stops, drop-off areas and public sidewalks are critical. Additionally, buildings and site amenities that are part of the event experience must be connected to these areas by an accessible route, i.e., a path that is wide, smooth and as level as possible without hazards or obstructions (see “Site Selection” in Chapter 2: “Advanced Planning,” page 17).

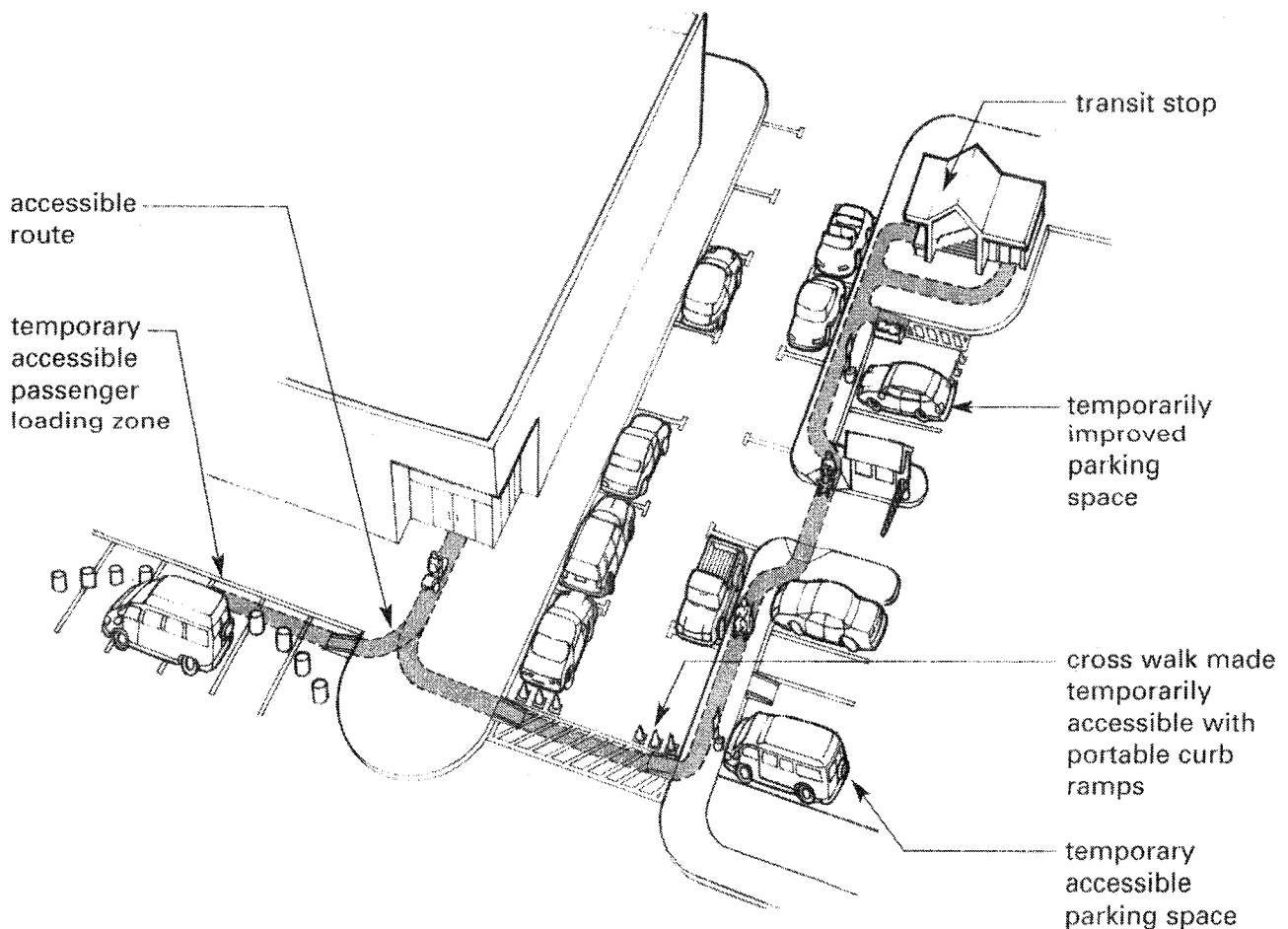

**Accessible Parking and Drop-off Points Must Be Located on an Accessible Route that Connects to Accessible Entrances**

## GENERAL CONSIDERATIONS

As always, it is best if permanent changes that conform to the ADA Standards can be made. This may not always be possible; however, there are many temporary “work-around” modifications that can be implemented for the duration of the event. Depending on unique site conditions and the particular mode of transportation, these modifications may vary significantly. Adequate signage, level changes at curbs, and the condition of traveling surfaces will always be concerns. When considering the extent and nature of the modifications it is important to consider what would be readily achievable for private businesses and nonprofit service organizations or would be part of program access for a state or local government (see “Modifications to a Site” in Chapter 2: “Advanced Planning,” on page 19).

### Signage

Signage is needed to direct the public to the location of accessible parking spaces, passenger drop-off points and transit stops. Such directional

signage is critical where these features are positioned in only a few select locations. Signs may also be needed to direct and identify accessible entrances and gates once a participant has reached an arrival point. Signs should include the international symbol of accessibility, use easy-to-read (simple serif or sans serif) type faces, and be large enough to be read from a distance (see “Signage” in Chapter 4: “Participating in the Event,” on page 59).

Manufactured signs displaying the accessibility symbol can be readily purchased from vendors who offer a varied selection of directional and parking signs. Stencils of the international symbol of accessibility, along with simple letter faces, are also available and can be used to create clearly legible signs — a good solution which allows flexibility where unique instructions must be given. Hand lettering can even be used as long as it is clearly readable from a distance.

Signs can be mounted on manufactured portable sign posts, mounted directly on buildings and fencing, or secured to posts set in buckets of concrete or placed in the ground.

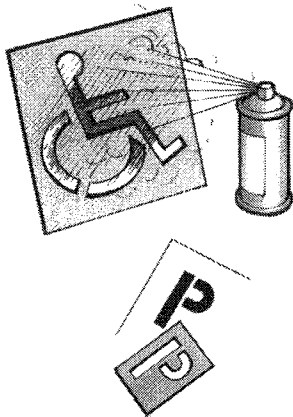

**Stencils Can Be Used to Make Easy to Read Signage**

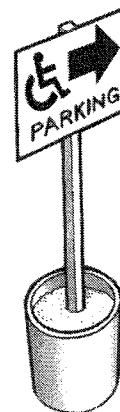

**Signs May Be Bought or Made**

### Curb Ramps

Curbs along streets and parking lots are frequently encountered barriers. Curb ramps, or "cuts," are utilized to overcome level changes created by curbs. A curb ramp designed to meet the specifications of the Standards must have slopes no steeper than 1 in 12. They may have flared sides that slope as steeply as 1 in 10 if the flare is not directly in the pedestrian path of travel, perpendicular to the curb ramp.

Numerous manufacturers now fabricate portable ramps, with some specially designed to bridge curbs and appropriate for use at a temporary event. For safety reasons, it is critical the ramp be designed not to move or shift from frequent use and is securely attached so a person would not tip over or fall out of their wheelchair or scooter. Temporary wood curb ramps also can be fabricated as needed.

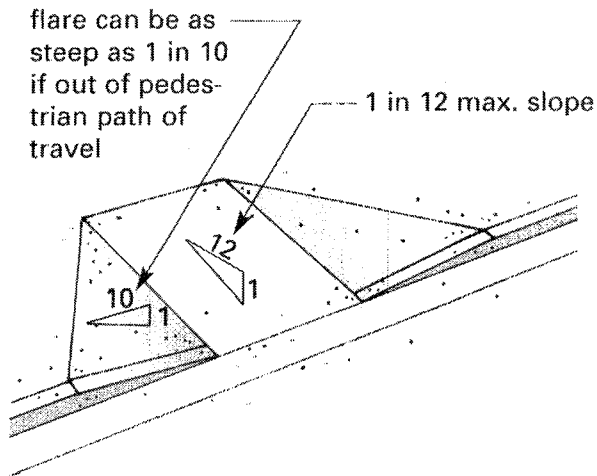

**Typical Flared Curb Ramp  
Used in New Construction**

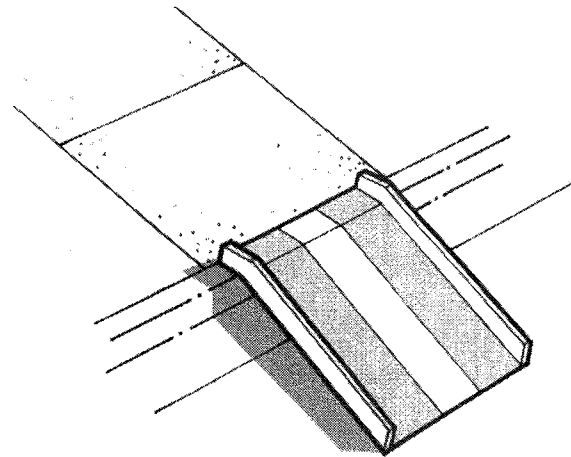

**Manufactured Portable  
Curb Ramp**

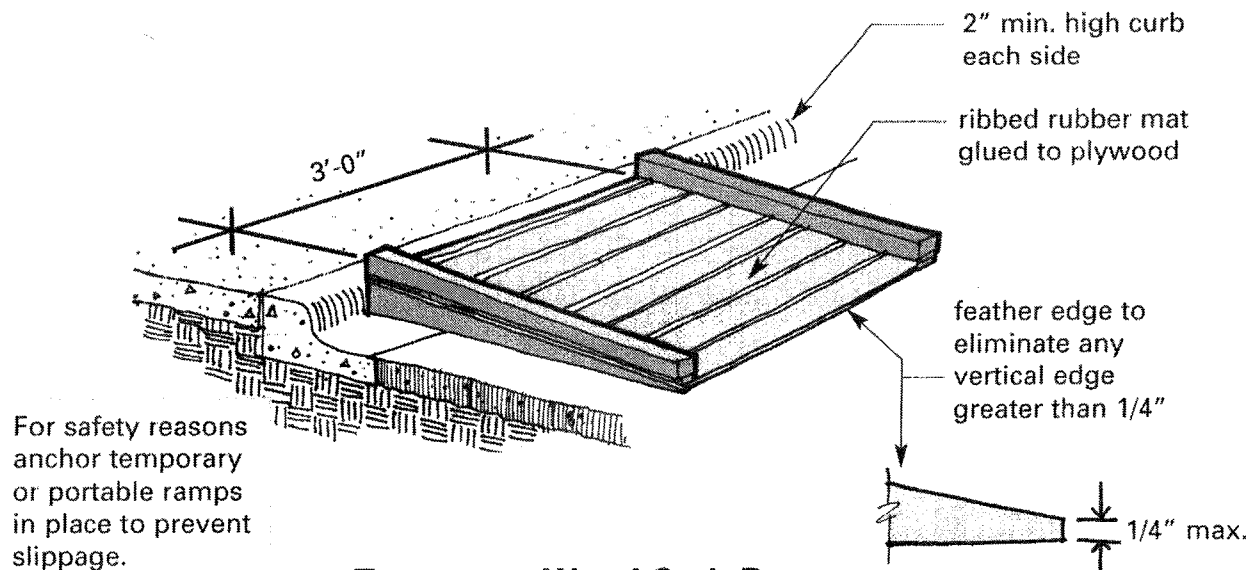

**Temporary Wood Curb Ramp**

**Sidewalks**

Since there must be accessible routes from parking and other transportation areas to accessible event entrances, both the design and surface condition of those routes are critical. Pedestrian walks may have several changes of surface material along their length, for example, asphalt to concrete or concrete to brick.

Small abrupt level changes often occur at material changes and they may pose a tripping hazard or an obstacle to someone using a wheelchair. Other common conditions that create small level changes are the effects of weathering and tree roots that may cause outdoor surfaces to crack or buckle, forming small hazardous drop-offs. All abrupt vertical changes greater than 1/4 inch should be repaired or, where appropriate, should have small bevels installed to create gradual transitions (see "Accessible Route" in Chapter 4: "Participating in the Event," page 46).

**Barricades**

A frequently used device in achieving temporary access in areas normally reserved for vehicles is the use of barricades. Barricades may be used to temporarily define maneuvering space for people using wheelchairs or to protect a portable ramp location. Traffic cones and barrels, sawhorses, or even cinder blocks and wood planks also could be used, provided the barricade looks intentional, is heavy enough to remain stable during inclement weather, and resists vandalism. At least a 32-inch opening in the barricade must

remain clear so people using wheelchairs may pass through but vehicles may not.

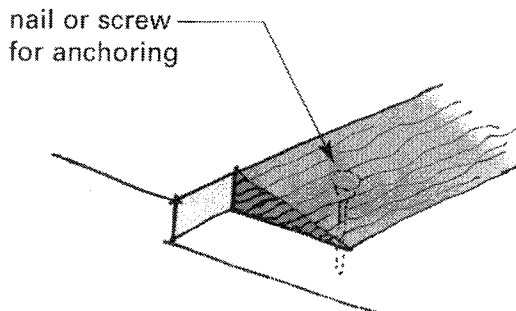

**Use of Bevel to Correct Small Changes in Level**

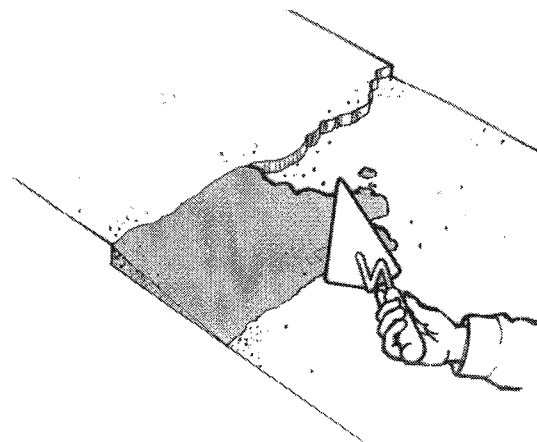

**Repair Cracked Surfaces**

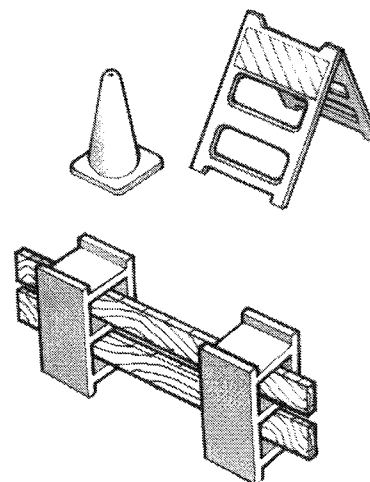

**Items That Can Be Used As Barricades**

**PARKING**

To use parking spaces safely, people with wheelchairs or other mobility aids need more space than is available at typical non-accessible parking spaces. To provide adequate space for car doors and van lifts to open and for users to maneuver, each accessible parking space must be equipped

with a level access aisle. To conserve on space, two parking spaces may share one access aisle. Accessible parking spaces must be as close as possible to a main event site or building entrance and be connected to that entrance by a smooth, level path without curbs or obstructions, i.e., an accessible route.

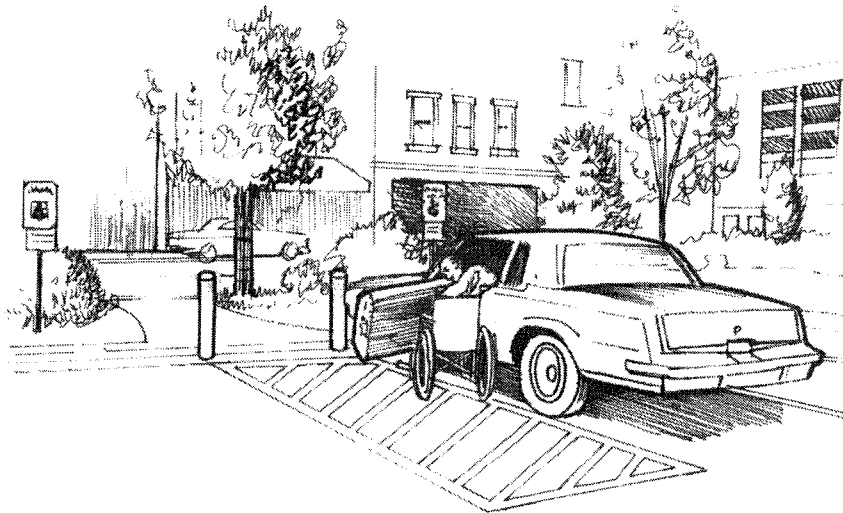

**Number**

At a minimum, there should never be fewer accessible parking spaces than specified in the ADA Standards (see table on this page). Of these, at least one in every eight accessible parking spaces must be “van accessible.” Van spaces, to be usable, must have access aisles that are wider than the 60-inch minimum specified for cars. To provide sufficient room to deploy a lift, access aisles for van spaces should be at least 96 inches wide, the width of a typical parking space. For events catering to a specific audience, the number of accessible spaces may have to increase beyond the minimum if the event is directed toward a population consisting of a large number of people who have mobility disabilities, for example, a function specifically for people who are older.

**Accessible Parking Spaces**

Total parking in lot	Required minimum number of accessible spaces
1 to 25	1
26 to 50	2
51 to 75	3
76 to 100	4
101 to 150	5
151 to 200	6
201 to 300	7
301 to 400	8
401 to 500	9
501 to 1000	..... 2 percent of total
1001 to over	... 20 plus 1 for each 100 over 1000

\* 1 in every 8, but never less than one, must be van accessible

**Number of Accessible Parking Spaces as Specified in the Standards**

**Location**

**General:** Accessible parking spaces must be level and adjoin an accessible route to the accessible building/event entrances. Accessible parking spaces should be as close as possible, generally within 200 feet of an accessible entrance, to minimize the need for a person with a disability to travel long distances to merely arrive at the entrance.

It is preferred that all parking areas have accessible spaces. However, if one lot is closer to the event entrance, it may be preferable to locate all accessible spaces in that lot. The minimum number of accessible spaces provided must be based on the total of the number of accessible spaces required for each lot. If covered parking or unloading is possible, it is better to make this area available for people with disabilities, as they generally take longer to get into and out of vehicles.

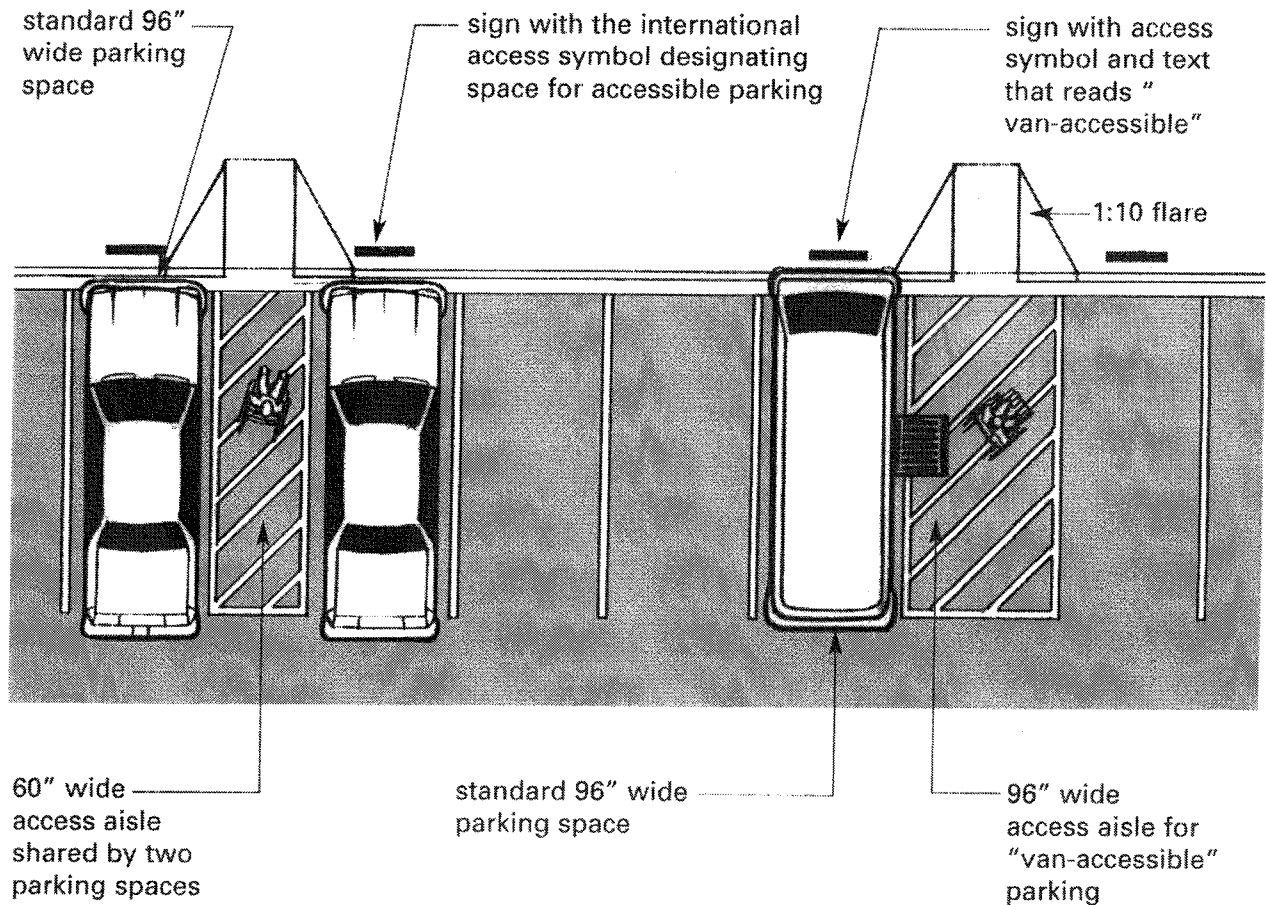

**Parking Spaces and Access Aisles**

**Parking Garages:** Parking garages may be problematic because the vertical clearance at the entrance may be too low to accommodate personal vans equipped with raised roofs, a feature on many accessible vans. As stated in the Standards, vertical clearance for van-accessible parking spaces is 98 inches minimum. Some personal use vans require even greater clearance, thus a vertical dimension greater than 98 inches is recommended. Van-accessible spaces may be provided in alternate locations outside the garage, but as close as possible to an accessible entrance and at no additional inconvenience to the driver/passenger with a disability.

**Off-Site Parking:** For many events, a significant portion of or all parking may be located in areas not adjacent to the site where event activities are occurring. It is crucial that accessible routes be provided to and from accessible parking spaces in these areas. If the accessible route includes walks, streets, or parking facilities not under the control of the event organizer, it may be necessary to make prior arrangements to ensure that accessible spaces and routes to them are available (see Chapter 2: “Advanced Planning”).

Many of the temporary parking and walkway solutions presented in this chapter can also be used in off-site areas to provide workable solutions. One of the most critical issues are curb ramps for crossing streets and parking lots. It may be possible to request that curb ramps be installed or to use

strategically placed portable ramps as needed. It may be best under these circumstances to create accessible, temporary parking on-site and indicate its availability both on directional signage, as well as in publicity material (also see Chapter 2: “Advanced Planning”).

It may also be possible to use accessible vans or buses to shuttle people from outlying parking areas. This may be an awkward and large commitment of resources for an event if the use of shuttles is not already being planned for the benefit of other event participants. However, if a shuttle service is planned, the shuttle must be accessible and accessible parking spaces must be available in lots served by the shuttle.

**Note:** these are minimum vertical clearances, some vehicles will exceed 98” in height

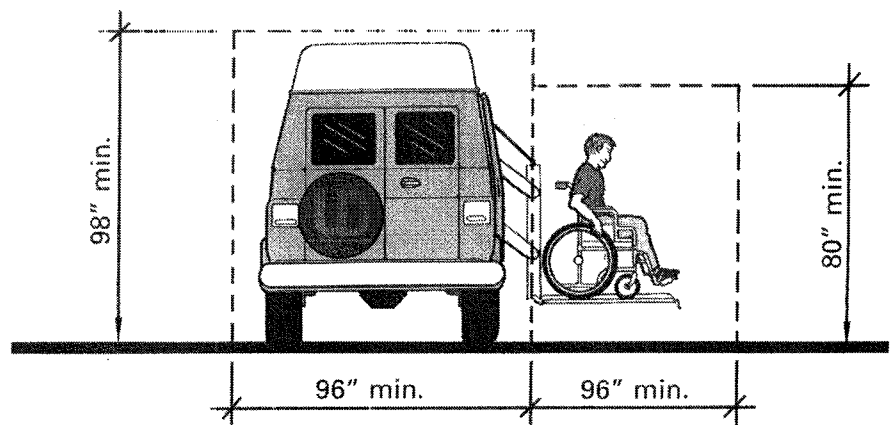

**Van Parking Space Vertical Clearance**

### Signage

Each accessible parking space should be clearly marked with a vertical sign displaying the accessibility symbol. Spaces with wider access aisles for vans should be designated as “van accessible.”

Signs also must be positioned in strategic locations along the site giving clear directions to the accessible parking lot/spaces if those spaces are not located within the general parking areas. This is especially critical when accessible spaces are separate from main parking areas. For example, it may be necessary to designate accessible parking along the street when parking lots have severe grades or parking garages have low vertical clearances.

If a temporary lot is used, accessible spaces still should be created and held in reserve (see “Creating Temporary Accessible Parking Spaces,” page 41). In addition to signage, staff or volunteers working as attendants at parking gates or booths and entrances should be aware of the location of accessible parking and be able to direct and assist visitors.

### Upgrading Out-of-Date Accessible Parking Spaces

While designated accessible parking spaces are now commonly found, many were built before passage of the ADA and, therefore, do not conform to the Standards. The most common problems are insufficient number, narrow access aisles, and spaces that lack or have improperly designed curb ramps.

To improve safety and usability, such spaces should be upgraded as much as possible to meet

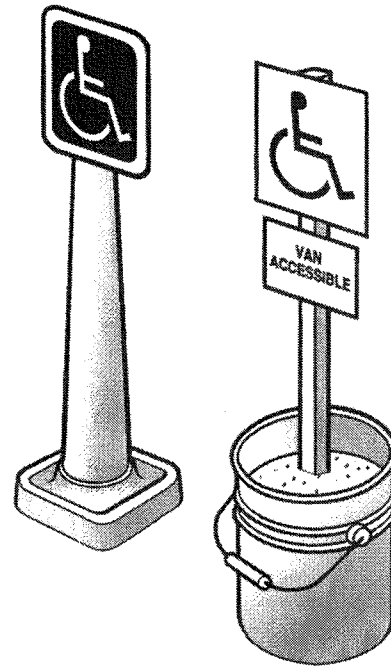

**Parking Space Signage**

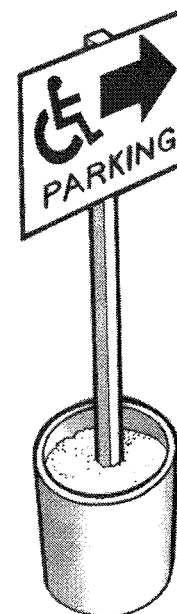

**Directional Signage**



the Standards. Parking modifications are generally straightforward, with the most complicated issues being severely sloping sites or tight space constraints. However, if permanent changes cannot be made or cannot be made in time for an event, there are temporary solutions to improve partially accessible spaces.

**Access Aisles:** Many access aisles are too narrow for vans, i.e., less than 96 inches wide, or too narrow for cars, i.e., less than 60 inches wide. A solution might be to block off the entire adjacent parking space and add that space to the access aisle, thus increasing the area available in which to maneuver a wheelchair or mobility aid.

This also is a good method for providing additional space around an existing curb ramp that projects into access aisles. When curb ramps extend into or overlap the access aisle, they create irregular surfaces at vehicle entry doors that make transferring onto wheelchairs difficult and unsteady and may prevent van lifts from fully descending. For these reasons they are not allowed in new construction.

**Curb Ramps:** Many existing curb ramps have slopes that are too steep, have too much surface warp or cross slope, and have insufficient room for a person using a wheelchair to turn out of the ramp onto a level area. These conditions are dangerous and can cause many who use manual wheelchairs to tip and fall.

Some people in manual wheelchairs, power wheelchairs, or scooters may be able to use steeper curb ramps (short run ramps) if the

slope of the ramp is between 1:8 and 1:10 for a maximum rise of three inches or between 1:10 and 1:12 for a maximum rise of 6 inches. However, longer ramps are dangerous if they have a slope greater than 1:12.

**A few solutions to problem curb ramps include:**

- adding a temporary ramp at another location even if it is necessary to create a new access aisle — the easiest method is to designate an entire parking space for this purpose because no additional striping of the lot is necessary
- installing edge protection where none exists.

extended curb ramps create irregular surfaces at vehicle entry doors

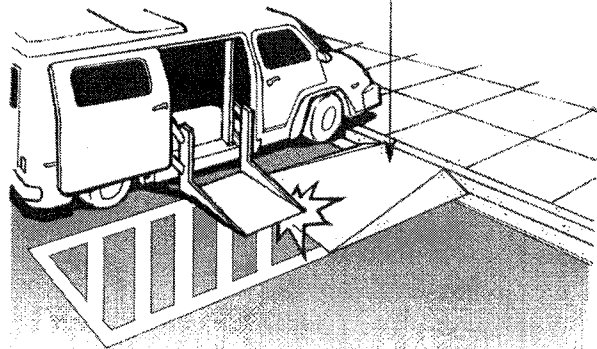

**Extended Curb Ramps Can Be an Obstacle**

Exposed drop-offs on curb ramps where no side flares are provided is a hazard, especially when used in a situation where crowds are present. Anyone could accidentally travel off the edge of the ramp and twist an ankle due to the abrupt level change. This condition is especially hazardous for people using wheelchairs who could be pitched out of their wheelchairs onto the pavement.

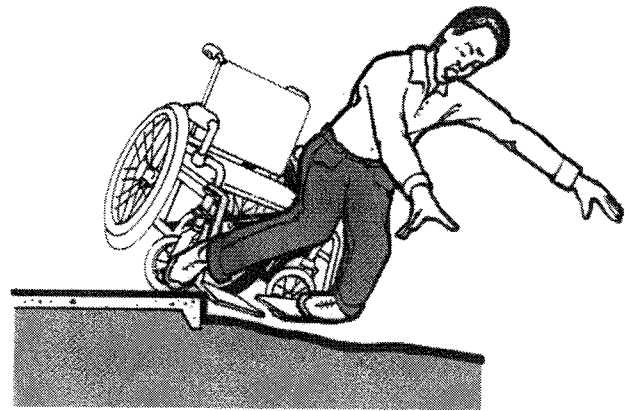

**Lack of Edge Protection at Curb Ramps With Drop-Offs Can Be a Hazard**

Railroad ties, planters, masonry blocks, and similar large objects set along the edge of an exposed drop-off can provide a warning and a physical barrier. Such objects should project at least two to four inches above the surface of the ramp. The best method to prevent an actual fall is to securely attach a permanent feature such as a return curb or side flare to the exposed edge of the ramp.

edge protection prevents crutch tips and small caster wheels from slipping off edge of surface

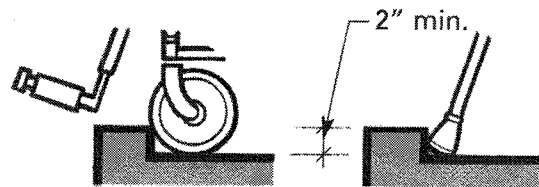

**Curb Detail**

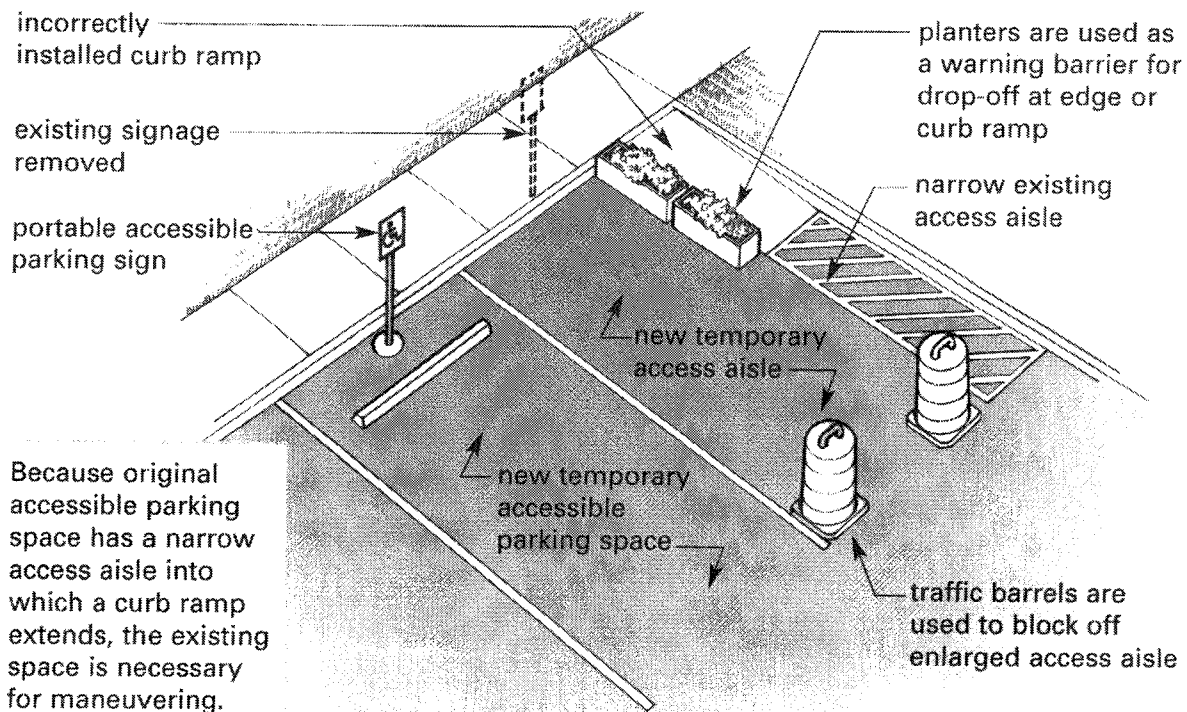

**Temporary Modifications To Improve Partially Accessible Parking Spaces**

### Creating Temporary Accessible Parking Spaces

Where there are an insufficient number of accessible parking spaces or when none can be provided in time for an event, temporary accessible spaces can be created in permanent paved lots as well as in dirt lots or fields.

**Existing Parking Lots:** When no accessible parking spaces are available, select spaces that are level, close to an accessible entrance and, where needed, near existing curb ramps.

Mark or block off an existing parking space with cones, barricades, or pavement marking tape to create a new access aisle. The parking spaces on either side are then designated as accessible spaces and indicated with a sign displaying the accessibility symbol. If no existing curb ramps are available and if the new parking spaces abut the sidewalk, a portable curb ramp can be placed in the temporary access aisle to gain access to the sidewalk level.

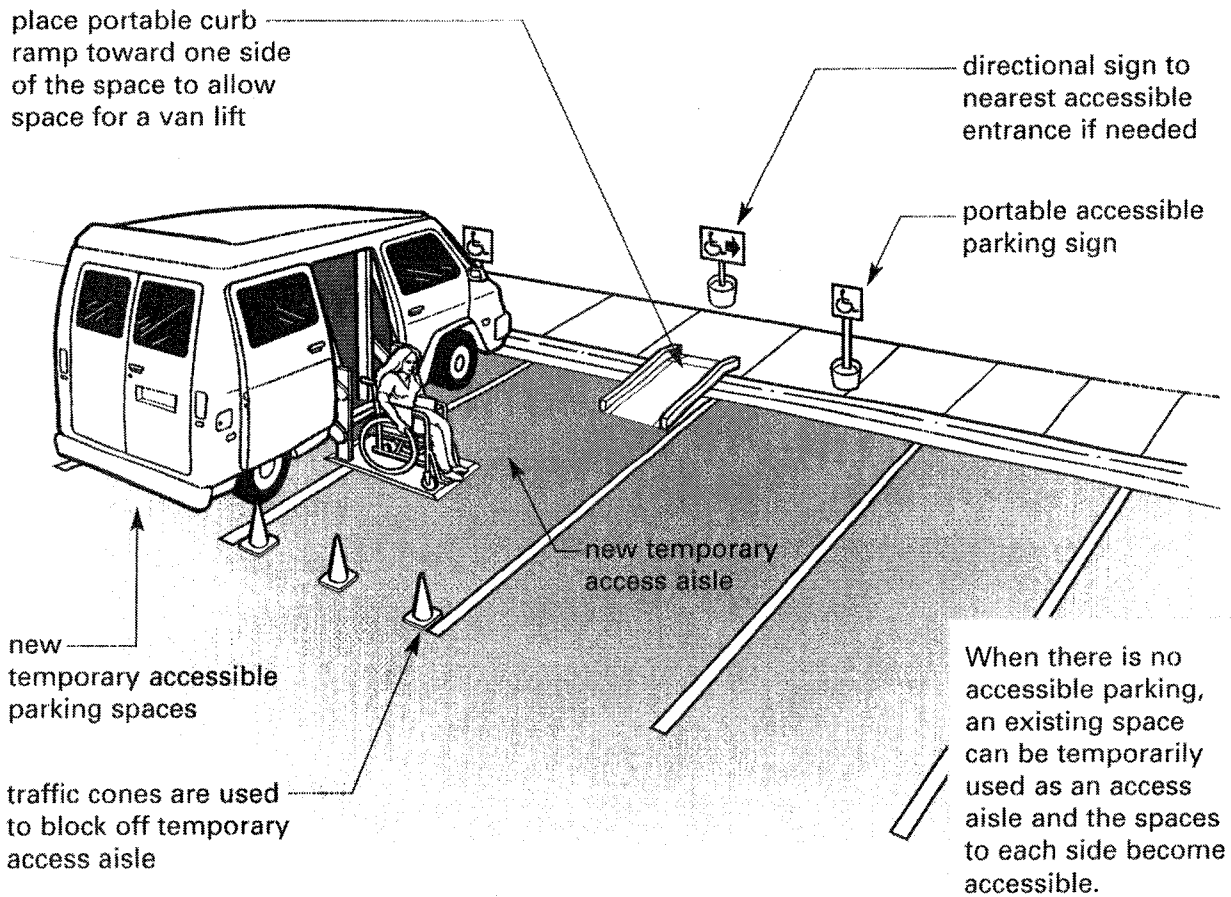

### Temporary Modifications To Create Accessible Parking Spaces

**Temporary Parking Lots:** Grass fields or dirt lots used as temporary parking areas usually have no marked spaces. Most likely, participants will arrive and be directed to a parking space. Accessible spaces must be created and held in reserve for people with disabilities.

Accessible parking spaces should be located where the surface is firm and stable. Dirt should be hard and compact and grassy areas closely cut to ground level. Loose sand, gravel, and overgrown grassy areas are too difficult to travel across for many people using wheelchairs or those who walk with difficulty. Sites that become slippery or muddy when wet will not be usable by everyone. If it is possible to find a paved lot with an accessible route, consider locating some of the accessible parking there to give participants with disabilities a choice to avoid these adverse conditions even though they may have to travel a marginally longer distance to reach the event entrance.

As with all accessible parking, those designated in temporary lots should be level and near accessible entrances. The space should be laid out in accordance with the Standards and identified with the accessibility symbol. Use crowd control fences, traffic cones, and/or similar barricades to set aside accessible parking areas, and designate each space with a sign displaying the accessibility symbol (see “Signage,” page 38). As there is not likely to be a defined pedestrian route, something as close as possible that approximates an accessible route should be planned from the parking access aisles to the event entrance.

It may be possible to lay down certain types of plastic or rubber matting over unstable natural surfaces to make them navigable (see “Natural Surfaces” in Chapter 4: “Participating in the Event,” page 50). These may work to create an access aisle or cover short pedestrian routes. However, it may be impractical to cover long distances.

It is preferred that people using wheelchairs not be required to travel behind parked cars or to cross vehicular traffic lanes. If this is unavoidable, the pedestrian route (especially where the route crosses traffic lanes), access aisles, and parking spaces should be clearly defined. Methods and materials to use include, but are not limited to, use of chalk or aerosol paint, ropes and stanchions, crowd control fences, and barricades at key points.

## DROP-OFF POINTS

### Transit Stops

For many people, public buses, subways, and trams are the most convenient means of transportation. For others it is their only way. Ideally, a public transit stop would be located on or near the event site; however, this may not always be possible. In those cases, an accessible route from the transit stop to the site may not be available.

**Accessible Routes:** A route to a transit stop usually is not accessible because it lacks curb ramps. With public sidewalks, the local city or county government can be requested to install curb ramps where needed. If this is not possible then locate an alternate accessible route making use of existing curb ramps or position

portable curb ramps where they can be used safely.

Portable curb ramps can be placed in a street side parking space that is blocked off expressly to create an accessible street crossing. The alternate route may deviate from a more direct inaccessible route. Directional signage must be provided to alert the public of the accessible route to the event.

### **Passenger Loading Zones**

If shuttles are being run from outlying parking areas or from a transit stop to the event site, or if participants are to be dropped off before a driver parks a vehicle, it is important that an accessible space be provided for this activity. Passenger loading zones provide a defined area where people can be conveniently and safely dropped off and picked up outside the flow of traffic. These loading zones are necessary for people with disabilities who often require additional space and time to get in and out of vehicles or who cannot travel long distances.

A loading zone designed to the specifications of the ADA Standards has a vertical clearance of at least 114 inches clear for personal vans with raised roofs, buses, and paratransit vehicles. The loading and boarding space should be 20 feet long and at least five feet wide alongside the pull-up space for the vehicle.

#### ***Existing Passenger Loading Zones:***

Many facilities and sites may already have an area designated as a passenger loading zone; however, these spaces often lack curb ramps. If enough space is available, block a portion of the area off and use a portable curb ramp.

Another common problem is over-hanging canopies that lack sufficient vertical clearance for raised roof vans or buses to pull underneath. It may be necessary to create temporary loading zones in other locations to accommodate these vehicles. This is critical if an event is relying on public buses or shuttles to bring people with disabilities to the site.

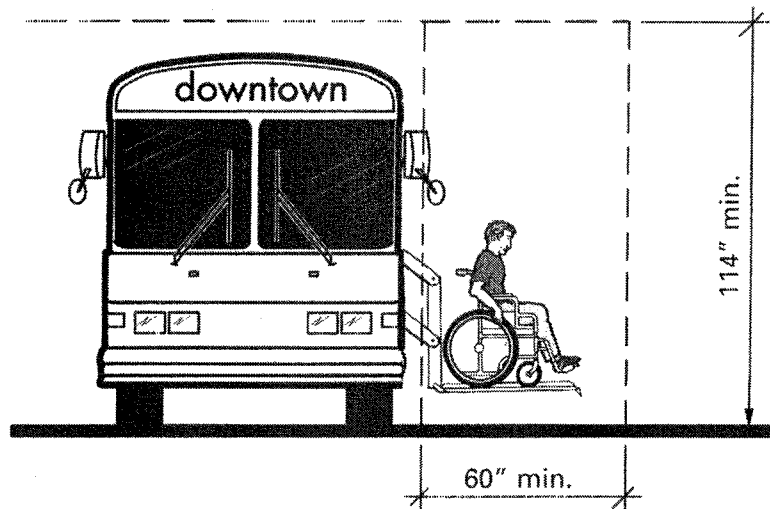

**Loading Zone Vertical Clearance**

**Temporary Passenger Loading Zones:**

Temporary passenger loading zones can be created by blocking off areas along streets and driveways or in parking lots. These locations require sufficient area to allow a vehicle to pull out of traffic. If creating a new loading zone, it is recommended that the 20-foot long by 5-foot wide boarding space, identified above, be enlarged to eight feet

of width. This provides additional space necessary for the deployment of some van lifts. Due to space constraints, it may be necessary to locate the temporary passenger loading zone away from the event entrance. If this is the case, provide directional signage and an accessible route to the location.

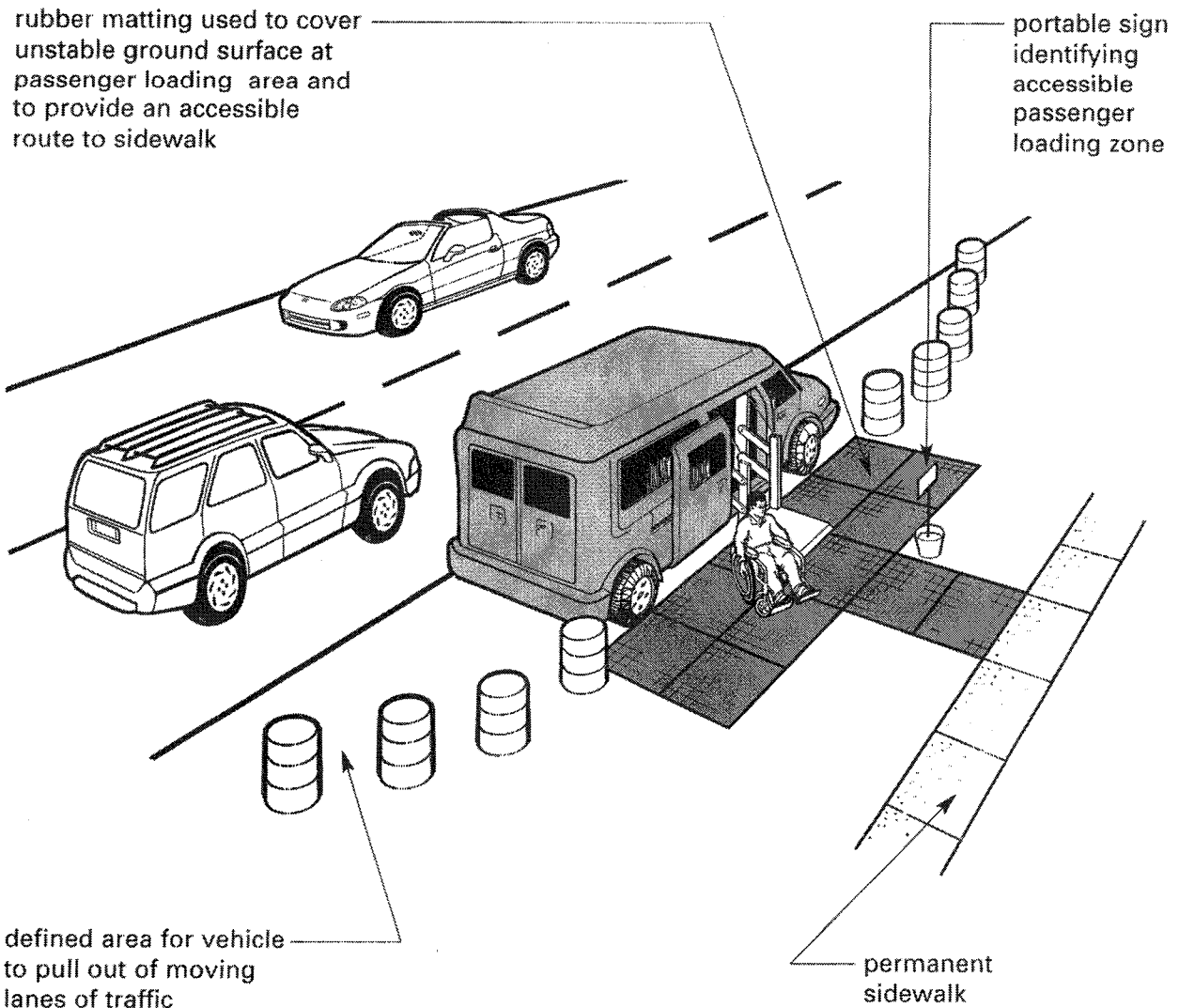

**Temporary Passenger Loading Zone**

# CHAPTER FOUR

## PARTICIPATING IN THE EVENT *Getting Around and Taking Part*

### INTRODUCTION

People with disabilities must be afforded an equal opportunity to participate in or benefit from the activities and amenities provided at a temporary event. Thus, all event participants must be able to get around the event site and view or take part in most activities, if not all.

This chapter is devoted to assisting event planners, event staff and building owners in creating the most accessible physical and experiential environment possible. It offers different levels of solutions to common problems encountered when holding temporary events.

The chapter is divided into two parts: “Getting Around at the Event” and “Taking Part in the Event.” “Getting Around” focuses on the nuts and bolts of creating an accessible facility and emphasizes the importance of the accessible route to people with mobility disabilities. It also addresses issues critical to people with sensory disabilities.

The second section of the chapter, “Taking Part,” focuses more on the steps to take to make the core activities of the event itself, the programs, the games, the exhibits, and the performance areas, accessible. In general, the discussions within this chapter are cross-disability so readers are able to find most pertinent information on a topic in a single location.

Much of the concept of accessible route is predicated on ensuring that people who use mobility aids may successfully navigate through

the environment. The concept of accessible route is discussed in greater detail on page 46. But, because the spatial needs of people using wheelchairs impacts so significantly on the design parameters of the accessible route, knowledge of key dimensions describing maneuvering space for people using wheelchairs is helpful.

A space 30 inches wide by 48 inches long is necessary to accommodate an adult seated in an average-sized wheelchair. This is the minimum floor area needed to park a wheelchair in a stationary position when, for example, viewing an object or sitting at a table.

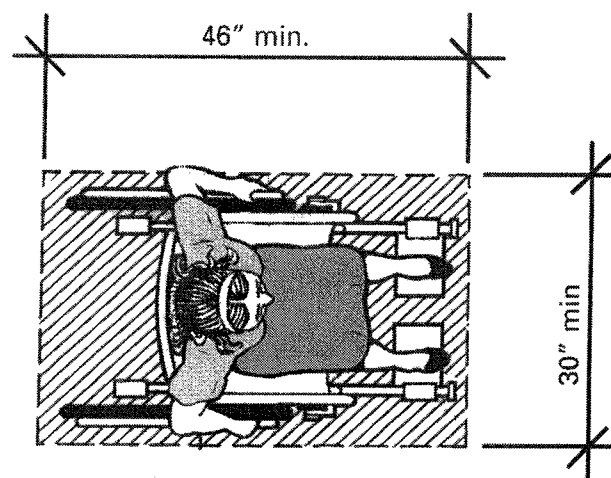

**Minimum Clear Floor Space  
for Wheelchair**

The space necessary for people using wheelchairs to make a 180-degree turn is a circle with a diameter of 60 inches. Alternatively, a person can make a T-shaped turn, similar to a three-point turn in a car, at the intersection of a hall, between display cases, or where some of the space necessary to perform the turn may be under a counter or table.

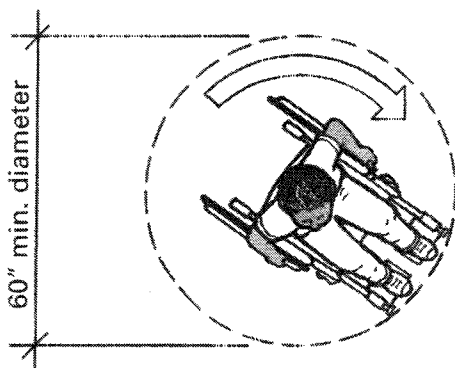

**Pivoting Turn Space**

## GETTING AROUND

### Accessible Route

An accessible route of travel is the key unifying element that facilitates the safe and independent use of a site and its buildings by all people, especially people who must use wheelchairs or walking aids or who walk with difficulty. A successful accessible route connects site arrival points, i.e., parking, bus stops, etc., with all exterior and interior event exhibits and activities, including public amenities, such as toilet rooms, water coolers, and telephones. This single continuous path should be smooth, but not slippery, as level and as wide as possible without low or overhanging hazards or obstructions, and not require the use of stairs.

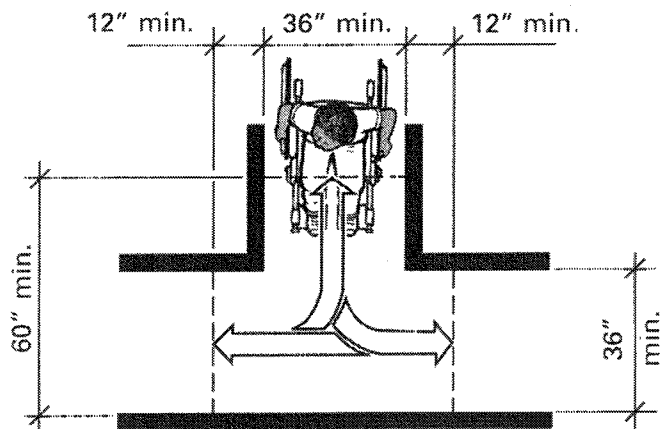

**T-Turn Space**

Any site being considered for a temporary event must have an existing accessible route or one must be created. The route, as much as possible, should be the same route as that used by other participants. Modifications to create accessible routes may be temporary or as permanent as resources allow. Once a route has been mapped out, it must be identified with signs if it deviates from paths used by the general public. For a pedestrian path to be considered an accessible route, at a minimum, it must meet the following criteria:

- Be at least 36 inches wide. Exception: at doors or short passageways, where the accessible route may be reduced to 32 inches in width for a maximum distance of 24 inches.
- Have a minimum 60-inch by 60-inch clear space, at least every 200 feet, so two people using wheelchairs may pass.



- Have a minimum of 80 inches vertical clearance or headroom along its entire length.
- Be free of any hazardous, protruding objects.
- Be on stable, firm, slip-resistant and compact surfaces.
- Slope no more than 1:20 unless a ramp with handrails and edge protection is installed. Ramps are limited to a slope of 1:12. All cross slopes are limited to 1:50.
- Have no abrupt vertical changes in floor or ground level unless it is limited to 1/4 inch with vertical changes between 1/4 inch and 1/2 inch permitted only if the change is beveled with a slope of 1:2 or less.
- Level changes greater than 1/2 inch, such as a step, stairway, or full floor level, can be accomplished using a ramp, lift, or elevator.

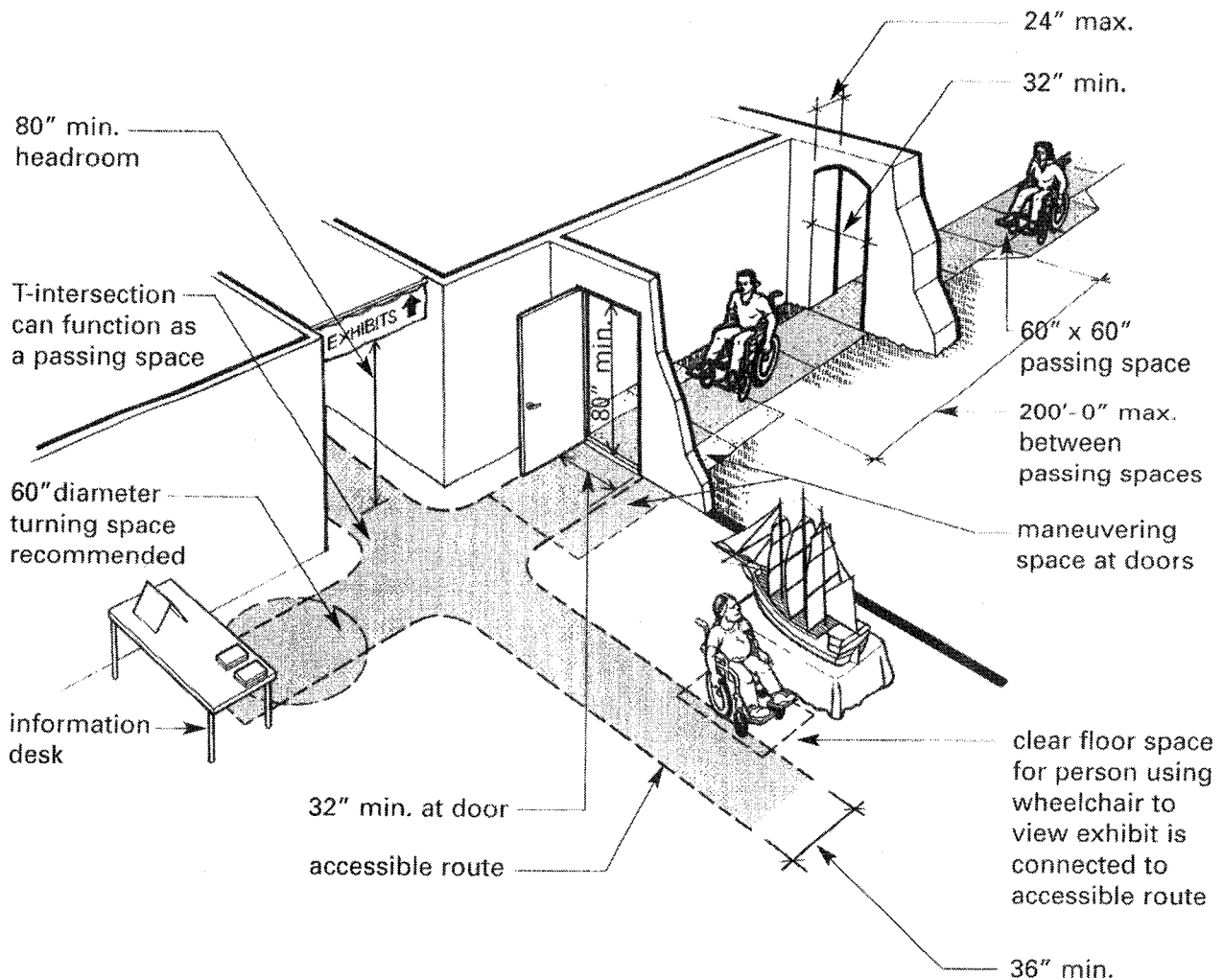

**Basic Features of an Accessible Route**

Given conventional construction methods and the age of many facilities, certain site and building features likely will not comply with one or more of the criteria for an accessible route and present problems to people with disabilities. Areas and features which usually require special attention are entrances, ground and floor surfaces, partial or full floor level changes, and doors.

### Entrances

After arriving on the site and traveling from parking, transportation stops, or public sidewalks, event participants with disabilities must be able to get to and through entrance gates and building entrances. The accessible route to these entry points must be free of stairs unless a ramp,

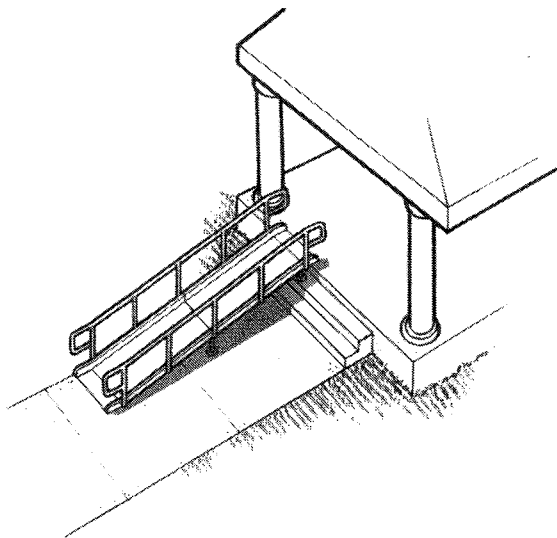

**Portable Ramp Used at Inaccessible Building Entrance**

lift, or elevator is also provided. The ADA places emphasis on having people with disabilities use the same entrance as other visitors. Therefore, modifications to accomplish this should be a priority.

If an entrance is inaccessible, but not so far above grade as to be impractical to modify, the entrance could be made accessible by installing a portable ramp or lift (see “Changes in Ground and Floor Levels,” page 53). Where existing main entrances are inaccessible and too difficult to modify, another entrance more easily altered should be selected. When multiple visitor entrances are provided for a temporary event, and not all are accessible, signs displaying the International Symbol of Accessibility must be installed to direct visitors to accessible entrances.

The most common barrier at building entrances is the interior floor level raised above the exterior grade level. Solutions for such changes in elevation are the same as for other changes in level (see “Changes in Ground and Floor Levels,” page 53). There are at least three entry door and gate conditions unique to building entrances that may require attention. These are discussed below.

**Revolving Entry Doors.** Many people, especially those who use mobility aids to move about, cannot successfully pass through revolving doors. In fact, the ADA Standards prohibit revolving doors from being part of an accessible route. Often, one or more swinging doors are placed adjacent to revolving doors, usually intended as emergency or service entrances.

These auxiliary doors may be used as the accessible entrance during the duration of a temporary event. However, this necessitates the doors remain unlocked and, if no door hardware is present or door closers are too heavy, staff must be available to assist participants or doors should be propped open (see "Doors," page 55).

Revolving doors are not usable by people using wheelchairs, walkers, strollers, hand trucks and other wheeled vehicles or by people who are blind

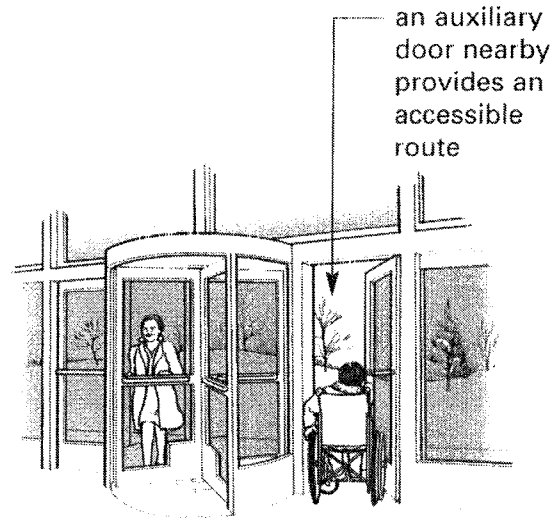

### Auxiliary Door at Inaccessible Revolving Door

**Entry Vestibules.** Double door vestibules, where maneuvering space is limited, can trap people using wheelchairs. There should be at least four feet between the second door in its open position and the first door. If this is not the case, the inside or second door can be removed or propped open for the duration of the event. Other issues at entrance doors are similar to those for doors in general (see "Doors," page 55).

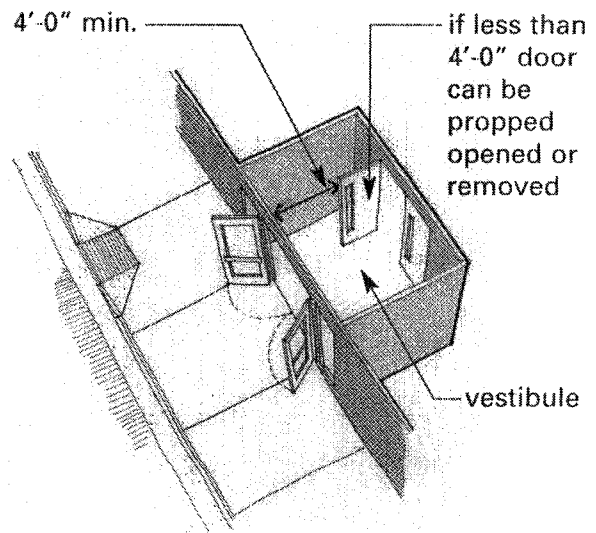

### Double Door Entry Vestibule

**Turnstiles.** Ticket gates that incorporate turnstiles present barriers, similar to those found at revolving doors, to people who use mobility aids. An alternate accessible route must then be provided and, if possible, placed close to the entrance used by other participants. Security guards or other personnel must be prepared to allow people with disabilities to pass through auxiliary or service gates as needed.

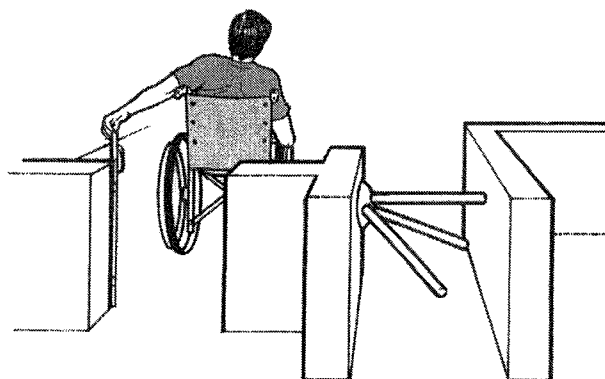

### Auxiliary Gate at Turnstile

### Ground and Floor Surfaces

Rolling over soft loose surfaces such as deep pile carpet, sand, or gravel is difficult or impossible for most manual wheelchair users. People who use powered wheelchairs or scooters may also have difficulty on these surfaces since extra force is required to travel across them. This can drain batteries quickly and could leave a person stranded.

Irregular surfaces, such as cobblestones and similar uneven brick or concrete pavers, are uncomfortable as these can cause wheelchairs to rock and tilt. Unstable and uneven surfaces also can be a problem for people who walk using crutches or canes, often causing a loss of balance or promoting falls.

**Natural Surfaces.** Crushed stone or soil, if compact, stable, and free of loose debris, is often a usable surface on which to hold a temporary event. If the surface is grass, it too may be serviceable if the soil is not soft and the grass is cut close to the ground. Tall grass is often slippery and difficult to roll a wheelchair across.

The usability of exterior surfaces also is greatly affected by weather. A grass playing field, acceptable in dry conditions, can become slippery and muddy after a rain. Local weather conditions and time of year should be considered when planning activities. For some activities, it may be a good idea to have an alternate indoor location available.

Synthetic matting can be used to temporarily provide a compact and stable surface over sand, gravel, or wet areas. Low profile, non-slip rubber

doormats might work for short distances provided their edges are secured or beveled.

Interlocking rubber tiles are probably the best method of providing an accessible route over unstable ground surfaces, especially when long distances must be covered. Another good option is perforated plastic mats because when laid over grass the grass is not killed.

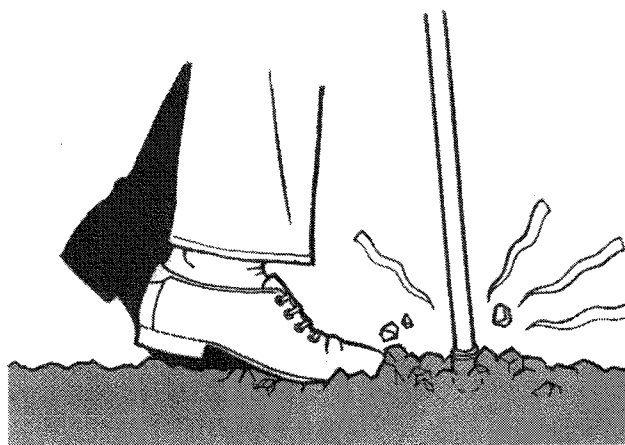
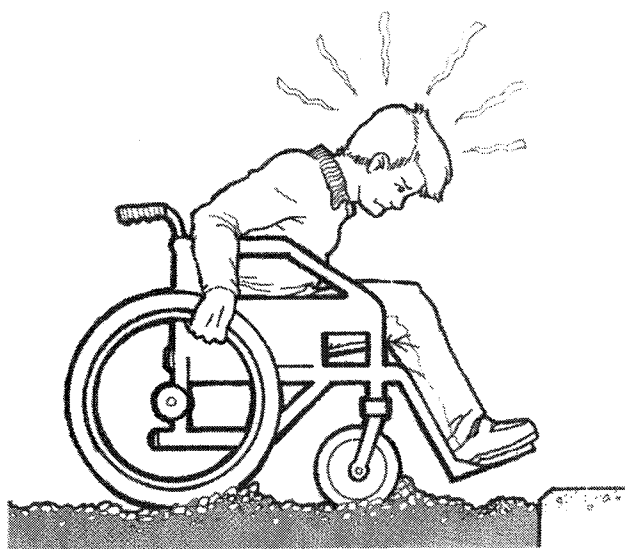

**Loose Sand and Gravel Are Difficult for Many People**

interlocking rubber tiles or plastic matting provides a stable usable surface for people using wheelchairs, scooters, walkers and strollers

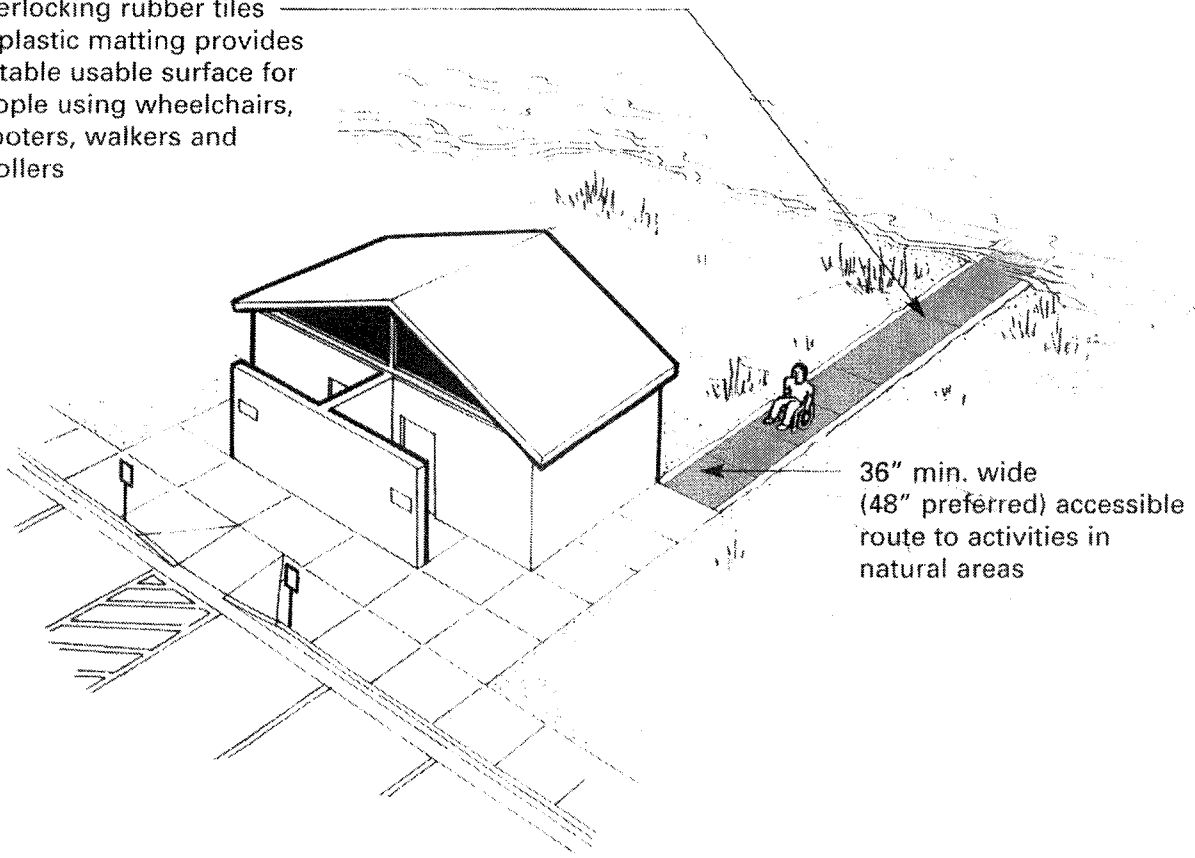

### Temporary Accessible Route Over Unstable Sand Surface

**Grates and Grilles.** A grate or grille located in the accessible route must not have any openings wider than 1/2 inch in the direction of pedestrian travel. Openings any larger can catch the tips of crutches or canes and wheelchair wheels, causing the occupant to pitch out of the wheelchair. Hazardous grates can be covered or blocked off or the accessible route redirected.

**Carpet.** Soft carpet is a common problem in many buildings. There is no standard test to determine whether a carpet is adequate or not. Generally though, carpets with thick pads or loose weaves are the most difficult to travel across. Where large numbers of participants

with disabilities are expected, and/or where travel distances over soft carpet are long, some accommodations should be made.

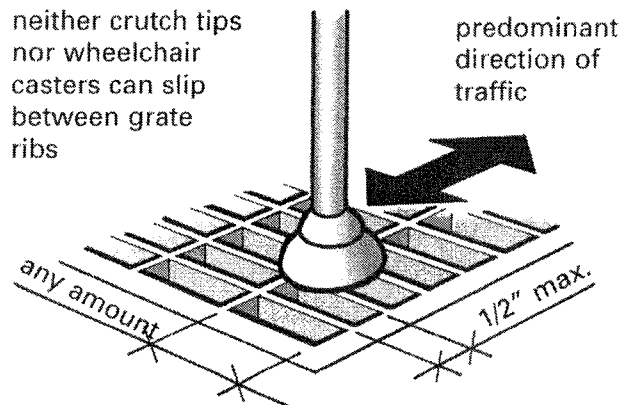

**Grate Opening in Pedestrian Travel Direction**

Consider rerouting the path for all the event participants or, a less desirable alternative, reroute the accessible route. Remember, it is important that, as much as possible, the accessible route coincide with the route used by the other event participants. It is possible that rolled surface materials similar to those referred to in the earlier discussion on “Natural Surfaces,” page 50, could be laid over existing carpet, provided the resulting surface is firm, not spongy or difficult to roll a wheelchair or walk across.

Loose carpet edges are tripping hazards and can catch the wheels of wheelchairs and scooters. All loose carpet edges and any add-on surface materials should be fastened or taped down. In the case of throw rugs and mats, they should be secured or removed.

**Small Abrupt Vertical Changes.** Small, abrupt vertical level changes often occur where surface materials change, such as from asphalt to concrete or brick to wood. This condition also can result as surfaces become buckled or cracked from wear or weather. Smooth transitions are always best because they also eliminate tripping hazards. However, people using wheelchairs and scooters can negotiate vertical changes of up to 1/4 inch.

Small abrupt vertical changes should be repaired or small bevels installed to create gradual transitions. Changes from 1/4 inch to 1/2 inch can be transitioned with a bevel sloped as steeply as 1:2. Small changes greater than 1/2 inch must slope at 1:20 (or in the case of a ramp, 1:12).

Bevels can be created with wood or other material planed into a wedge shape. For sidewalks and other concrete surfaces, it may be possible to trowel additional concrete onto cracked and uneven areas to smooth and level out the surface. If a vertical level change is high enough, it may require the use of a ramp, lift, or elevator.

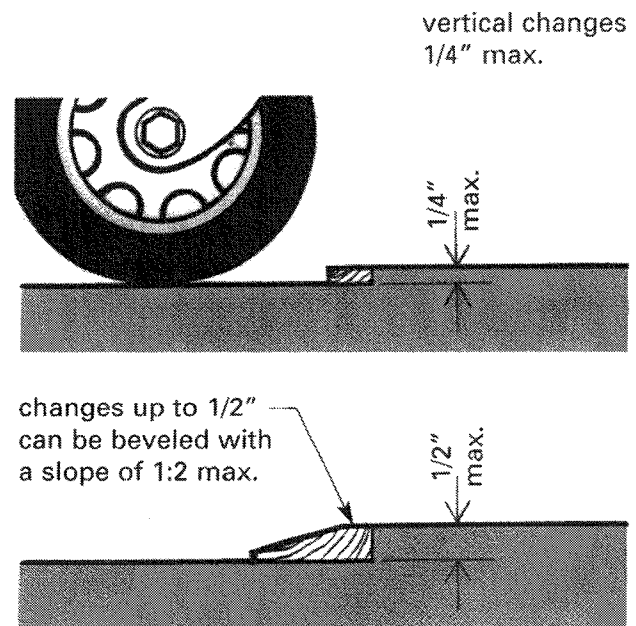

### Small Abrupt Vertical Changes

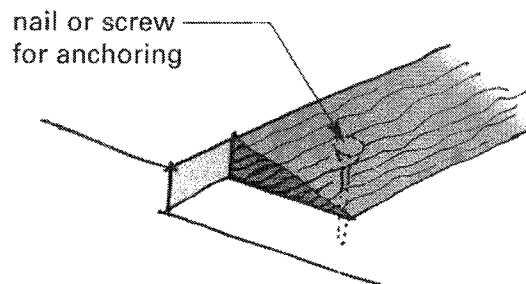

### Use of Bevel to Correct Small Changes in Level

## Changes in Ground and Floor Levels

Change in level is one of the biggest obstacles to traveling about a site and entering or moving within a building. Street curbs, steps, stairways, or building floor level changes are among the most common barriers. In addition to curb ramps (see “Curb Ramps” in Chapter 3 “Access to the Site,” page 33), these level changes can be overcome by installing ramps or platform lifts or making use of existing elevators.

If an area has an inaccessible change in level, it may be possible to redirect the accessible route and make use of other pathways and entries that do work or can be easily modified. Temporary ramps and lifts may be an option if an alternate route is not possible or if the alternate route would require a person with a mobility disability to travel an excessively long distance and/or take a convoluted path through areas not generally used by the public.

In many existing facilities, ramps and elevators may not meet the specifications of the ADA Standards. If either of these methods of getting between levels is being considered for use, they should be evaluated for adequacy and safety.

**Temporary Ramps.** Providing a temporary ramp maybe a good solution if stairs have a total rise of no more than 30 inches. (A note of caution: A ramp designed to allow someone in a wheelchair to safely climb a 30-inch change in level is 30 feet long). While it is possible to create ramps that bridge greater changes in level, such ramps are usually longer than are practical for a temporary situation.

Temporary ramps intended for use by the general public should comply with the ADA Standards specifications for ramps. There is some leniency in the degree of ramp slope (with rises of 6 inches or less) in existing buildings and facilities where space is extremely limited.

Ramps onto stages for a performer or presenter may be designed according to the individual’s needs. If these limited use ramps are steep they must be supervised during use and assistance must always be available.

Some of the key specifications for ramps that comply with the ADA Standards include:

- **a minimum width between handrails of 36 inches.**
- **a maximum slope of 1:12 (1 inch of rise for every 12 inches of run).**
- **no more than 30 feet of run before a landing or level resting platform is required for ramps with slopes between 1:12 and 1:16 and no more than 40 feet of run for slopes less than 1:16 to 1:20.**
- **slopes in existing facilities with extreme space limitations are restricted to between 1:10 and 1:12 for a maximum rise of 6 inches and between 1:8 and 1:10 for a maximum rise of 3 inches.**

Manufactured portable ramps are available equipped with all necessary features of an ADA complying ramp, i.e., appropriate width, slope,

for long periods of time or if reuse is anticipated, these ramps should be constructed of treated wood or otherwise be weather protected. Note: Ramps with a rise of six inches or less are not required to have handrails, but to prevent a user in a wheelchair from rolling off ramp sides, they must be provided with curbs or another form of edge protection.

Whether manufactured or fabricated, portable ramps must not move, shift, or wobble when in use. They must be securely attached or be designed to remain stationary at all times. This may require that a ramp be nailed, screwed, or bolted in place or sufficiently weighted to remain stationary.

**Temporary Platform Lifts.** For stairs with a rise higher than 30 inches, but not a full floor level, platform lifts may be a solution. Lifts also may work to transport people less than a 30-inch change in level where there is insufficient space to install a ramp. In some localities, it is possible to rent portable lifts from medical equipment dealers, independent living centers, or lift and elevator companies.

**Elevators.** The Standards have many requirements for elevators. The most critical factor in existing elevators is the cab size. If an elevator cab is too small, there is little that can be done to increase its size. At a minimum, the cab should be at least 48 inches by 48 inches. This does not, however, allow a person in a wheelchair room enough to turn around in the cab — obviously the larger the cab the better. And at events where there may be large numbers

of people using mobility aids and traveling between floors, it is important that elevators be large in size and in number.

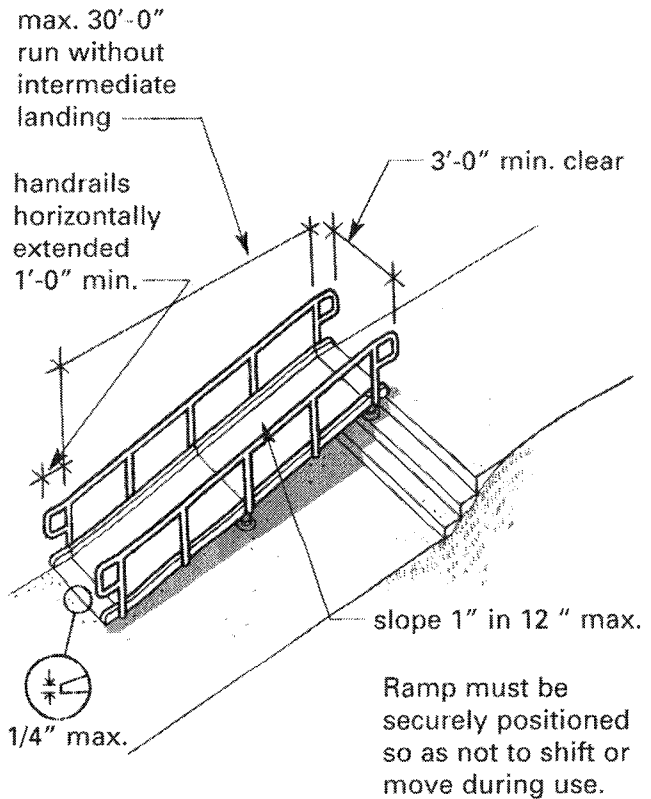

**Portable Manufactured Ramp**

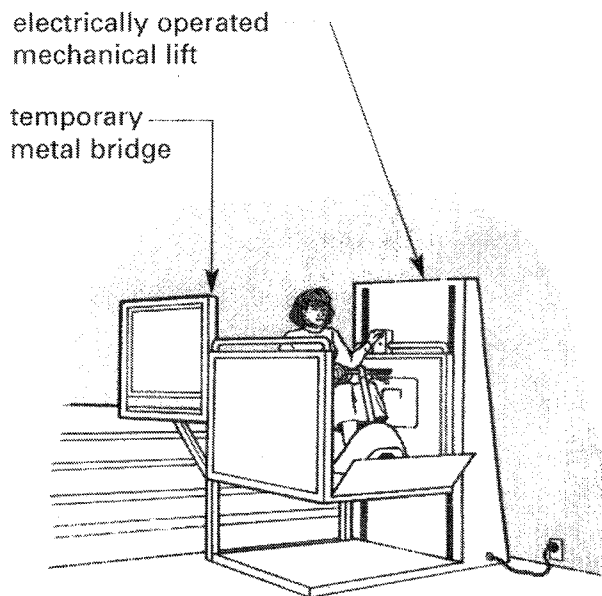

**Temporary Platform Lift at Stairs**



If a facility is large enough, there may be another elevator to utilize elsewhere in the building. Designating the freight or service elevator as the method for people with mobility disabilities to get between floors is the solution of last resort. Nonetheless, if it is the only option, it may be taken. If used, staff may be required to operate the elevator.

Generally, elevators installed in the last ten years have been designed to be accessible. However, even when cab size is adequate, other details should be considered to increase accessibility. Adding simple stick-on raised numbers on elevator jambs at each floor level and adding raised numbers and/or Braille at control panels that lack tactile numbering aid people with visual disabilities. Remember to provide signs directing participants to the “out-of-the-way” usable elevator.

## Doors

Outside some unique conditions at building entries and privacy requirements at toilet rooms, access issues generally are the same for most doors found on a site. Doors must be wide enough for a person using a wheelchair to pass through and be easy to open and close.

**Clear Width Opening.** Doors must have a 32-inch clear opening for people using wheelchairs to pass through without bumping into jambs. This usually means the door itself should be 34 inches wide or, preferred and easier to pass through, 36 inches wide. A door having a clear opening narrower than 32 inches can be

used by many people with disabilities, provided the door can stand open and sufficient space is available on either side of the door for a person using a wheelchair to line up with the opening before passing through.

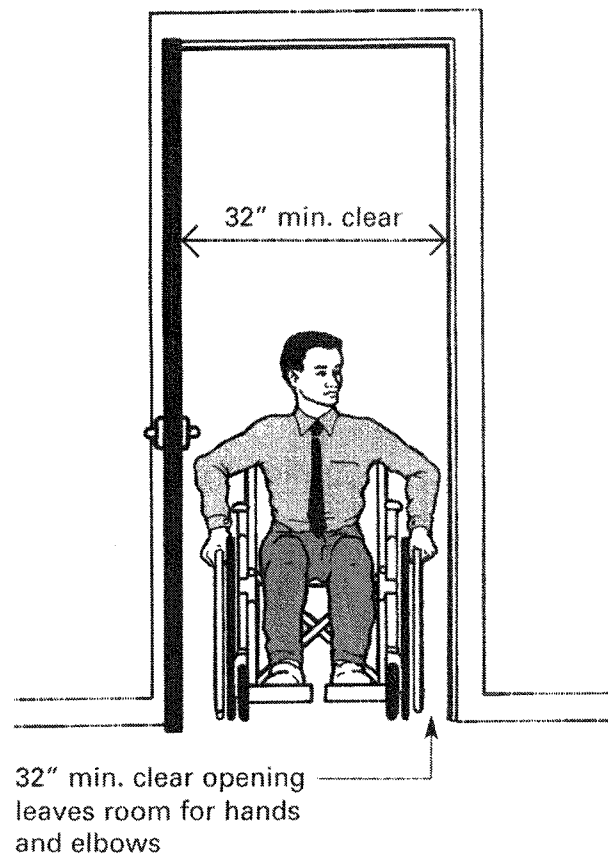

**Minimum Clear Width Opening**

There are some easy ways to enlarge a door opening by nearly two inches. When privacy, security, and air conditioning/heating requirements allow, the entire door leaf could be removed to gain clear opening width. A somewhat more permanent, and yet still economical solution, is to replace existing standard door hinges with swing-away hardware. This style of hinge allows the door leaf to swing completely out of the door opening, effectively providing the same amount of space as removing the door and still maintaining privacy.

**Door Opening Force.** Propping doors open can be an effective solution for a door which requires excessive force to open. Removing a closer or lessening its force is also an option for some doors. Interior doors should never require more than five pounds of force to open and, if possible, eight pounds for exterior doors.

**Handle Hardware.** Changing difficult-to-use knob handles to accessible lever or loop types are relatively easy changes. Add-on lever hardware is an economical solution. However, if neither of these suggestions are possible, consider the option of propping doors open.

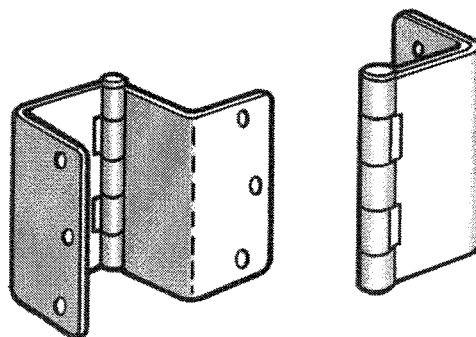

**Swing Away Hinges**

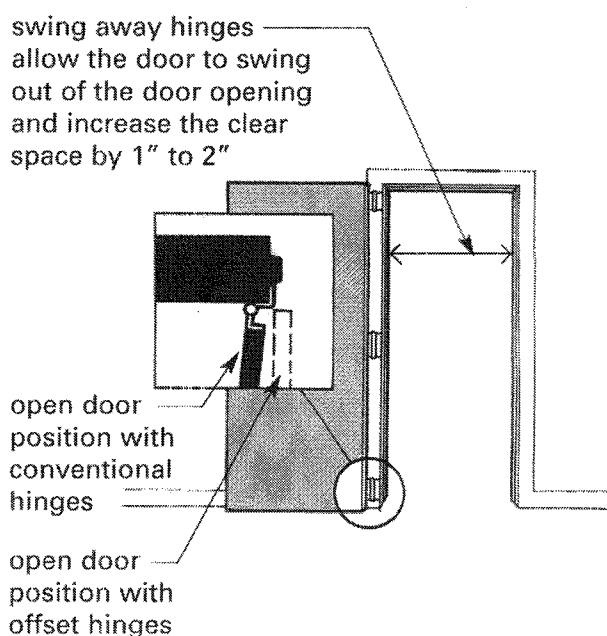

**Swing-away Hinges Can Increase the Clear Opening**

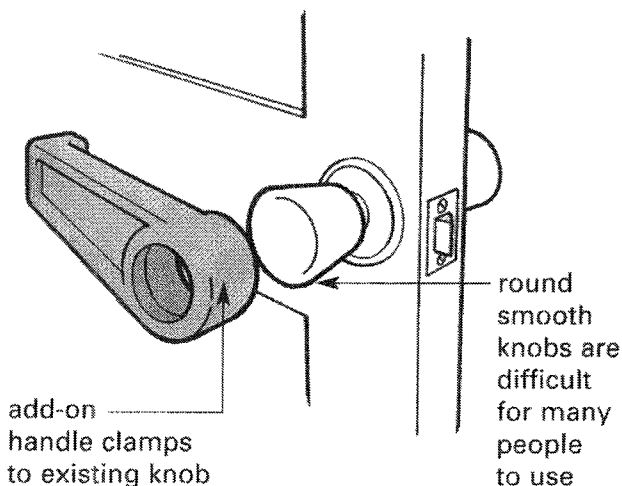

**Add-on Lever Handle**

## GETTING AROUND

### Eliminating Hazardous Protruding and Overhanging Objects

Objects that protrude from walls and posts, or hang from overhead, are not detectable by many people with visual disabilities or may even catch unobservant individuals. All interior and exterior circulation paths used by event participants and staff, including accessible routes and stairs, must be free of any such objects that pose a danger.

Typical site and building elements which may protrude into paths and thus be hazardous are signs, fire extinguishers, light fixtures, drinking fountains, and valve controls on standpipes. Likewise, parts of exhibits, sculptures, partitions, tent guy wires, or other structures brought onto a site for an event may also pose such a danger.

A wall-mounted object may not protrude more than four inches unless its bottom edge is detectable by a person with a visual disability using a long cane for navigation. The bottom of the protruding object must be no more than 27 inches above the floor or it must be mounted above 80 inches. Free-standing objects must also have a cane detectable element at or below 27 inches, if the object projects from its base more than 12 inches. Vertical headroom must always be at least 80 inches where a circulation path passes under an object or overhanging feature.

**Temporary Walls.** Wall panels are commonly used during events to delineate space and shape the environment. It is critical that they too be installed so as not to be hazardous. Overhead bracing must not violate the 80-inch minimum

headroom requirement and the bottom of display panels must be detectable.

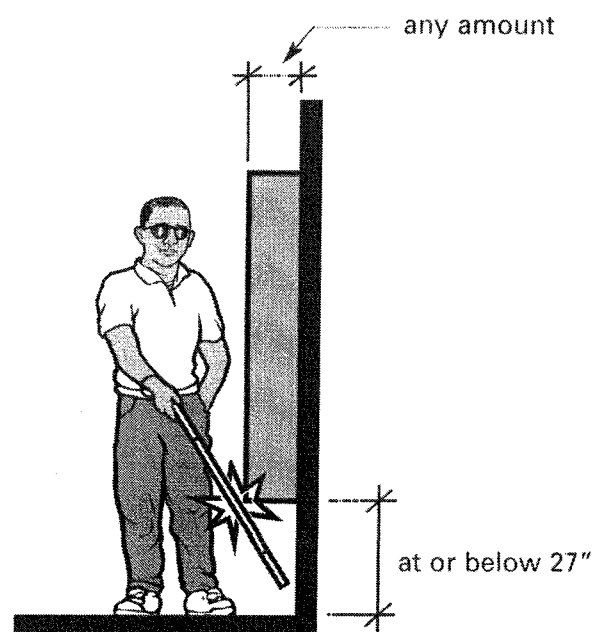
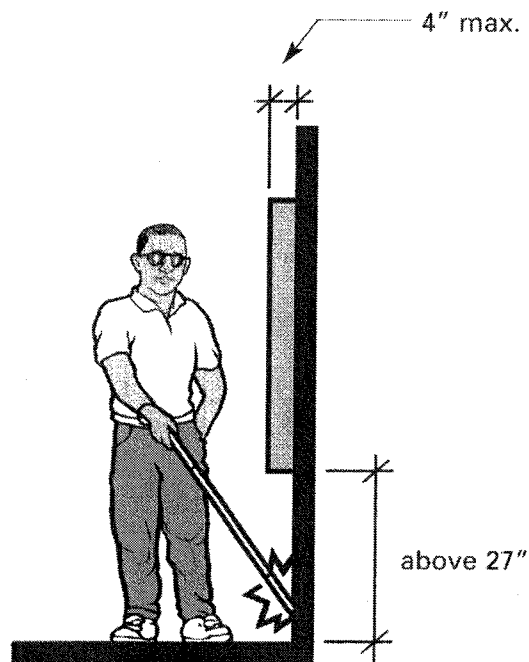

**Objects Mounted on Walls**

**Tents.** Tents, tarps, and similar temporary structures also are a key concern at many events. Guy wires for such structures should either be located out of pedestrian pathways or have a detectable barrier or element as a warning device. Support framework must also be evaluated for potential hazards and, if necessary, either modified or other designs selected.

**Open Stairs.** A common hazard is the open stairway with its sloped, underneath supporting structure. As the stringers and treads get closer to the floor, they violate the 80-inch headroom requirement. Furniture or planters that cannot easily be moved or shifted should be placed beneath the area with reduced headroom as a detectable barrier to direct people around the hazard.

of short stature can conduct business or review information. Where this is not possible, a lower auxiliary folding shelf can be installed on the

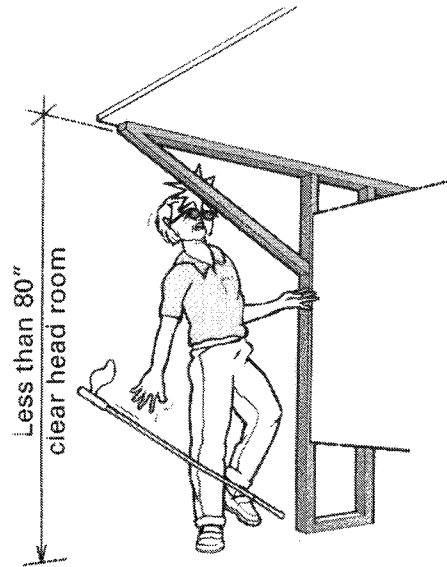

**Wall Panel Bracing Can Be a Hazardous Protruding Object**

**GETTING AROUND**

**Information and Ticketing**

Once on the event grounds or premises, the participant's first encounter is usually at a ticketing and/or information location such as an entrance gate, main desk, or information booth. It is critical that these spaces be accessible, both in the design of the space and in the information provided.

Information and ticketing desks or counters must be located on an accessible route that connects all event areas, from parking to the exhibits or activities offered. A section of the counter or desk should be available that is no higher than 36 inches and at least 36 inches long so people seated in wheelchairs and those

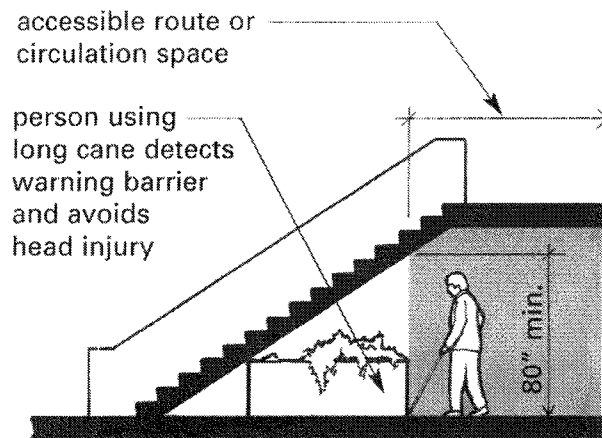

**Furniture or Planters Can Be Placed Under Open Stairs as a Warning Barrier**

front face of a high counter or desk. Another possibility is to place an accessible table in close proximity to the main desk to use as a supplement to the inaccessible counter.

Front-line staff at information and ticketing areas must have a thorough knowledge of accessible features and services offered by the event and a general sensitivity to disability issues. If staff are prepared, requests for information, directions, or assistance can be effectively and appropriately addressed, (see "Preparing Staff and Volunteers" Chapter 2: "Advanced Planning," page 34).

If event brochures, maps, or schedules are provided, and if resources permit, some should be available in large print for people with limited or low vision. Such literature can be enlarged on copy machines. Staff should be prepared to read literature aloud if requested by participants with visual disabilities.

For large events with multiple activities or where event directions or instructions are complicated, consider preparing an audio cassette tape that could be loaned, along with an economical cassette player, to people with visual disabilities or others who may not be able to read printed material. This may be more involved than possible for most events, but may be a successful solution for some.

Event directories, although exempted from conformance with the ADA Standards, should meet the general requirements of non-glare finish, character proportion, and type size to provide ease of use for all visitors (see the next section).

lower surface allows people who are seated or of short stature to write checks or review brochures and publications

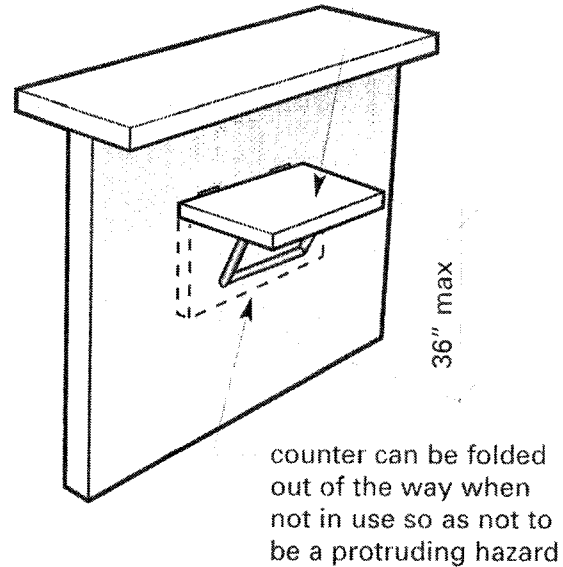

### Lowered Folding Counter Can Be Added at High Information/ Ticketing Desk

## GETTING AROUND

### Signage

Clear, easy-to-read signs placed in consistent locations help visitors find their way around an event site and make choices regarding which activities or exhibits to attend. This is particularly important for people with mobility disabilities, who may, because all paths are not accessible, be required to take an alternate route, and for people with limited vision who have difficulty reading signs.

Permanent building and site signs should be evaluated for their adequacy and, when possible, upgraded by facility owners to comply with the ADA Standards. Complying signs are divided into two general categories: those that identify

permanent rooms and spaces and those that provide information or directions. See the list on next page for specifications for each from the ADA Standards.

While it may not be possible to meet all the requirements in the ADA Standards for a one-time temporary event, some improvements can be made. If existing room signs are difficult to read or are too small, then the addition of temporary signs is a significant improvement. Any temporary signs, although not required to meet the provisions of the ADA Standards, should conform to the specifications for “directional” signs. Generally, all signs giving directions and information should be in large high contrast type that is easy to see at a distance, i.e., letters or numerals at least three inches high, if signs are overhead. Use easy-to-read typefaces (simple serif or sans serif) that contrast with background surfaces, such as black on white or white on black.

Signs that are “theme oriented” (e.g., “buoys” and “gulls” or “kings” and “queens” denoting restrooms), may not be understood by many people with cognitive disabilities. People with low vision will not be able to read signs that are highly decorative, printed on glossy surfaces, or poorly lighted.

Where only some routes are accessible, the accessible route should be indicated with signage that includes the international symbol of accessibility. In addition, accessibility symbols should be included on signs at accessible parking spaces and passenger loading zones, at accessible entrances, and at toilet and bathing facilities,

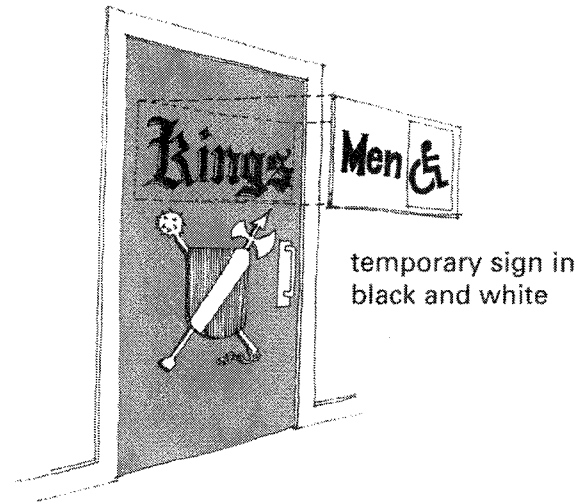

### “Theme Oriented” or Highly Decorative Signs May Not Be Understood

when all are not accessible. The appropriate sign must be displayed at text telephones and telephones with volume controls. Assembly areas with assistive listening devices also should have signs with the symbol of access for hearing loss, (see page 25 for the symbols from the ADA Standards).

Hand lettered signs may be used, but these should be executed in printed rather than cursive lettering and otherwise meet, as much as possible, the specifications for directional signs. Stencils are also an option to create clearly legible signs. It is possible to purchase manufactured signs that comply with the ADA Standards.

**Note:** Using an embosser designed specifically for this purpose, it is possible to augment partially complying signs by adding vinyl adhesive Braille labels. However, only a small percentage of the population that is blind reads Braille. Braille signs are most useful for the independent repeat building user who somewhat knows

where things are and uses signs to confirm their own location within a building or space.

These specifications are taken from the ADA Standards and are applicable if permanent building signage is provided.

### **Permanent Identification of Rooms and Spaces**

- tactile characters and Braille
- upper case sans serif or simple serif  
5/8" to 2" in height min. 1/32" raised
- high contrast and non-glare finish
- 60" above the floor on the latch side of the door
- allows close approach for reading and touching

examples include signs for toilet rooms, exit signs, room numbers

### **Informational and Directional Signs**

- simple design—no extended or condensed type
- high contrast and non-glare finish
- characters at least 3" high when 80 inches or more above the floor

examples include signs stating "cafeteria this way" and "Airplane Collection"

Helvetica

Avant Garde

**Univers**

### **Samples of Acceptable Typefaces**

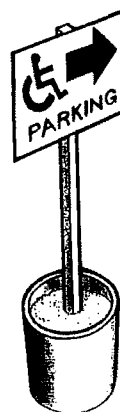

**Directional Sign for Accessible Route**

tactile signs can be deciphered by people with visual impairments

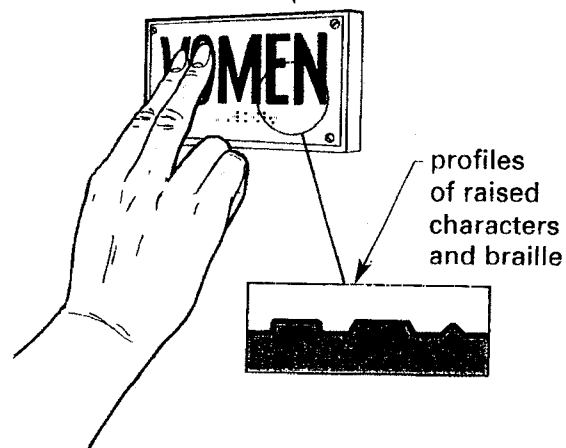

### **Tactile Lettering and Braille Required for Specific Permanent Building Signs**





## **GETTING AROUND AT THE OUTDOOR EVENT**

*Outdoor temporary events may be held in totally natural or completely fabricated man-made environments – ranging from a downtown's urban center to rural farm fields. The information presented in this illustration addresses many of the varied situations encountered when planning a primarily out-of-doors temporary event.*

*The following numbered statements correspond to the numbers on the illustration.*

**1-** Display, food and souvenir carts are located on accessible routes.

**2-** Stages, platforms or podiums may need to be accessible. Such stages are sufficiently large for a person using a wheelchair to maneuver and space is provided so a sign language interpreter can be seen clearly.

**3-** Cables, wires, equipment or vehicles brought onto the site must not interfere with accessible routes or pose hazards to people with vision disabilities.

**4-** In existing exhibition halls and auditoriums, ramps and lifts may be required to provide access. When these are located away from main public entrances, directional signs must be provided to clearly indicate their location.

**5-** Directional signage indicates nearest accessible route or entrance.

**6-** Accessible route to public transportation station.

**7-** If significant problems exist with transportation stops or accessible routes onto the event site, one solution is to provide a lift-equipped van or bus to the event.

**8-** When no on-site parking is provided, select the nearest possible parking area or garage and create accessible parking on an accessible route.

**9-** Events or displays located in adjacent buildings must be accessible.

**10-** Barricades used to block off streets must be positioned so they do not interfere with accessible routes or curb ramps.

**11-** Portion of parking lot used for children's carnival. Displays, booths and rides placed to allow an accessible route to all activities offered.

**12-** If only a portion of the parking lot is being used for the event itself, then existing accessible parking can be preserved.

**13-** Accessible parking spaces, as close as possible to activities should be provided in each of the various types of parking. On-street parking may not be fully accessible but some close-by spaces still should be reserved.

**14-** Display and activity booths for "street" festivals must be laid out to allow an accessible route to all activities and exhibits.

**15-** An accessible route must be provided to all exhibits, activities, and events located in city parks or greens.

**16-** Information booths must provide information about accessibility features provided on the site such as the location of accessible routes, parking and toilet facilities, or the level of access to different activities.

**17-** Temporary food "court" is located on an accessible route. Individual concession carts can be approached by people using mobility aids. If accessible service counter/table is not provided, then each vendor must offer to accommodate an individual by providing service in an alternate way.

**18-** Musical performance shown as part of this temporary event. In this instance, the stage is a permanent feature of the site and the audience sits on the sloping hill. No built-in seating is provided, thus, temporary access aisles are staked out. Some temporary folding seats are provided with wheelchair spaces located adjacent.

**19-** When portable toilets are provided, at least one in each cluster must be accessible.

**20-** Access provided onto temporarily constructed play area – sandbox play area shown.

**21-** This is an inaccessible route to the airplane exhibit. However, alternate routes that are accessible must be provided and should follow main circulation paths as much as possible. Directional signs also should be included.

**22-** Circulation features such as bridges or decks often have steps or small level changes. These features should be assessed carefully when planning accessible routes.

**23-** Large displays should be accessible if possible (temporary ramp shown). If not, some form of alternate access should be provided such as video and/or audio tape "tours."

**24-** The aircraft are located on level terrain to allow access to and around displays.

**25-** If displays have elements that protrude into circulation paths (here the rocket nose), then a cane detectable barrier must be provided or people with vision disabilities must be otherwise warned of the hazard.

**26-** During a temporary event, existing facilities are often converted to uses for which they were not originally intended. Careful attention must be paid to accessible routes, level changes, surface textures, security gates or other features which may not be an issue under other circumstances. Here, because the playing field is level, it converts easily to a performing area.

**27-** Temporary eating areas should provide accessible serving areas and dining tables (barbecue hut shown).

**28-** Bridge provides accessible route onto replica of Viking ship. If not possible to provide physical access onto floating displays, alternate method such as a video "tour" must be provided.

**29-** When locating exhibits or activities in natural areas (Indian village shown), try to select sites that have paths to allow access over or around barriers in the natural terrain such as rocks or streams. Paths should be level, firm, stable and clear of debris.

**30-** The location of temporary accessible parking should be indicated at gate.

**31-** On-site parking lot created specifically for the temporary event must have accessible parking spaces positioned as close to the event entrances as possible.

**32-** In rural settings, fences are a common barrier. Stairs or animal crossing gates are not accessible. In this section of the illustration, alternate routes are provided to the nearest vehicular gates which offer level access through openings in the fencing.

**33-** Access must be provided to rides offered (balloon and hay rides shown), however, not to the extent it fundamentally alters the nature of the activity.

**34-** At this gate, the cattle guard is partly covered to provide a level surface for an accessible route.

**35-** Displays are located along an accessible route.

**36-** Vehicular gate has a level wide entrance which allows access to the event.

**37-** This field has been selected for a rodeo. An accessible route is provided to all activities. The hay bales and saw horses erected to define the performing area are positioned so as not to block the sight lines of people who are seated in wheelchairs.

# GETTING AROUND AT THE OUTDOOR EVENT

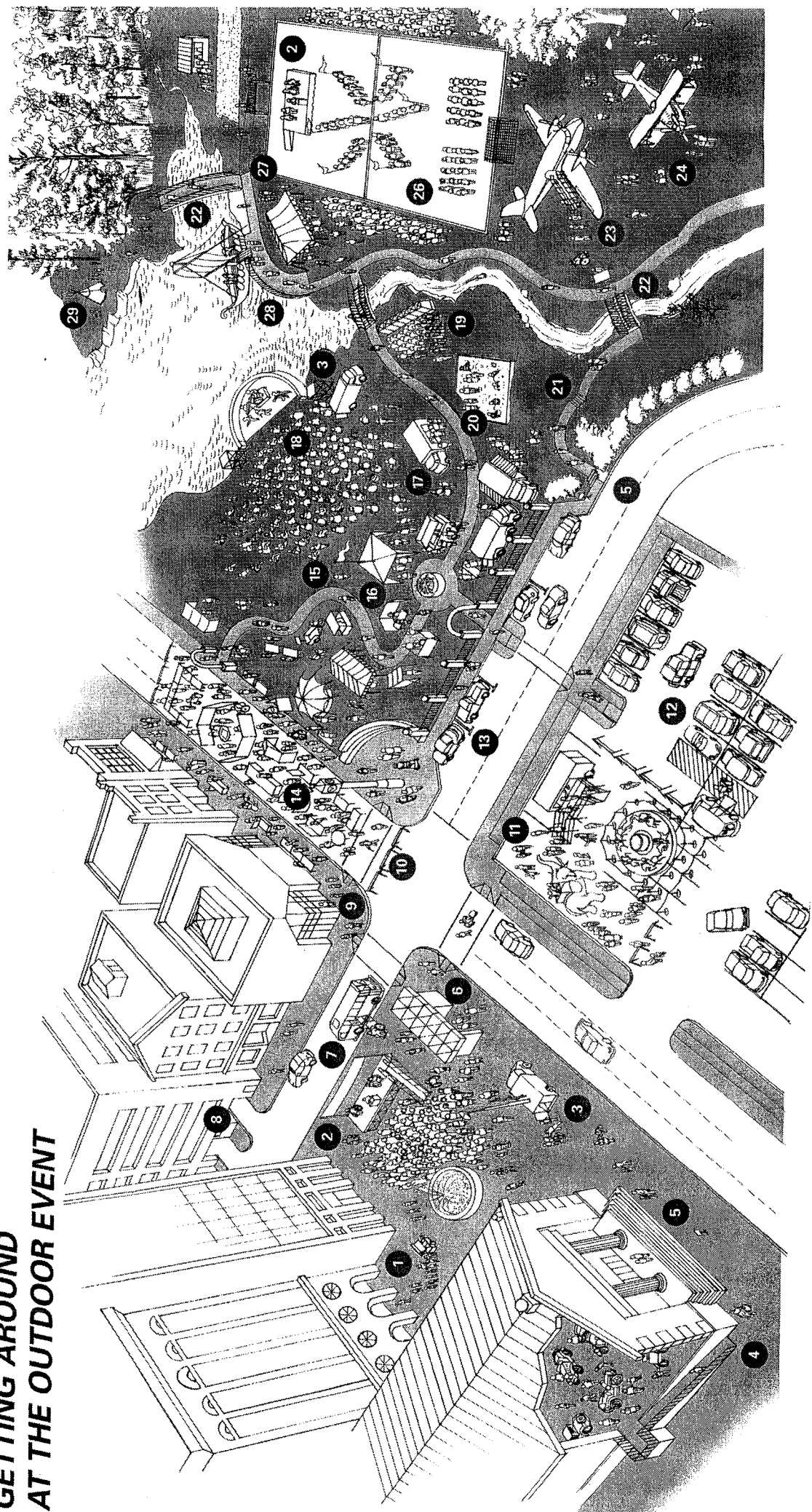

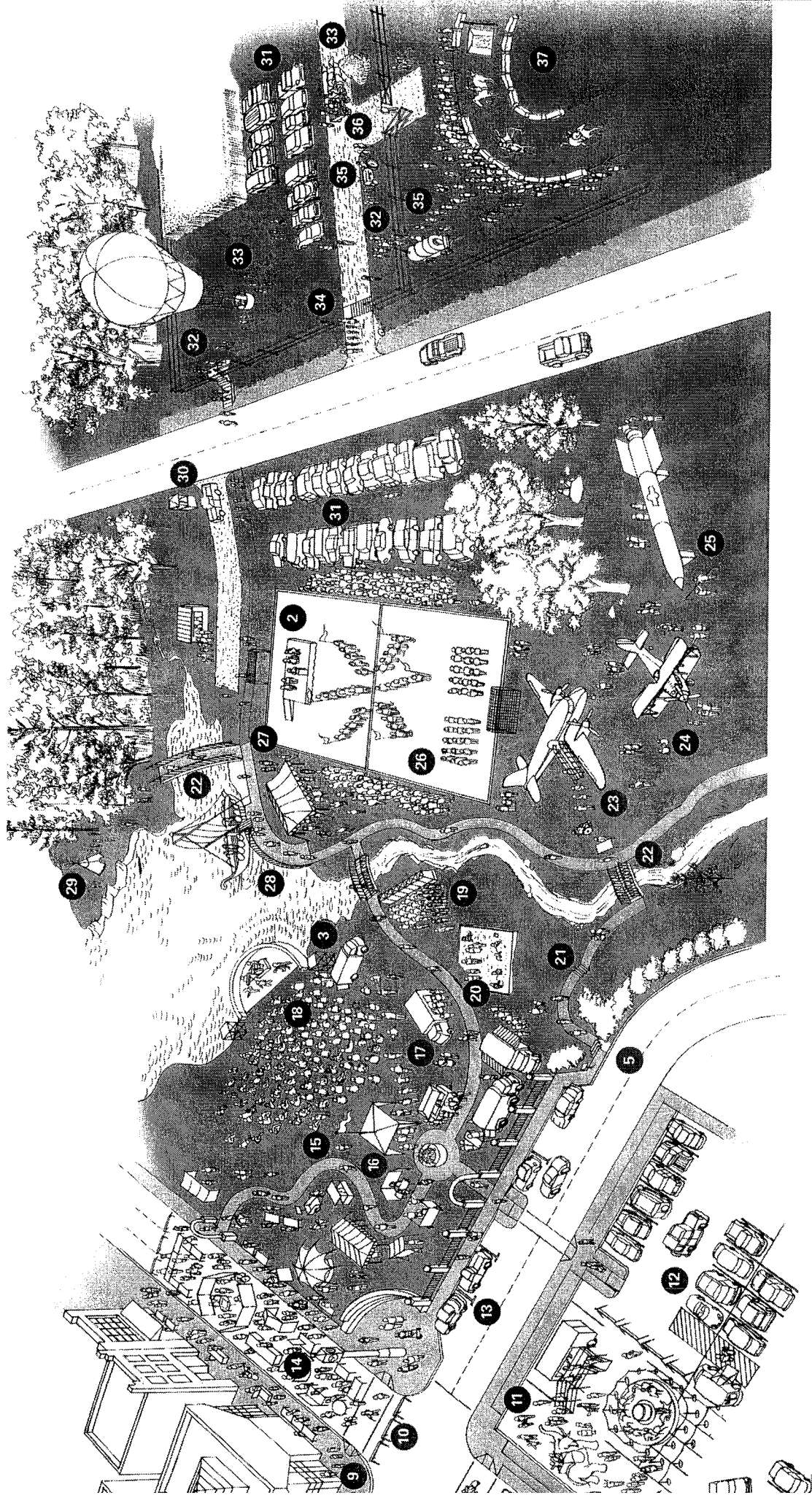

## TAKING PART

### Exhibits and Displays

Exhibits are common features of temporary events. Exhibits may be as simple as pieces of pottery set on a picnic table or elaborate traveling display cases exhibiting precious stones or jewelry for sale. Whether two-dimensional images or three-dimensional objects, these static items are usually displayed for the duration of an event with little physical manipulation expected of or by the observer.

The ADA Standards do not cover the design of elements that are not part of or attached to a building. Thus, portable display tables, cases, shelves, or panels that are generally transported into a space where a temporary event is to be held are not specifically required to meet the specifications of the ADA Standards. However, under Titles II and III of the ADA, it is expected that participants will be able to experience full enjoyment of the event. The following information is recommended guidance for making exhibits and displays accessible and should be considered when meeting the provisions of the law.

Display tables, cases, shelves, or panels, to be accessible, should be located adjacent to an accessible route and have adequate space for a person using a wheelchair or scooter to pass behind other participants who have stopped to examine an object. In addition, there should be sufficient clear floor or ground space on the viewing sides of the display to permit the same level of scrutiny of objects as afforded other

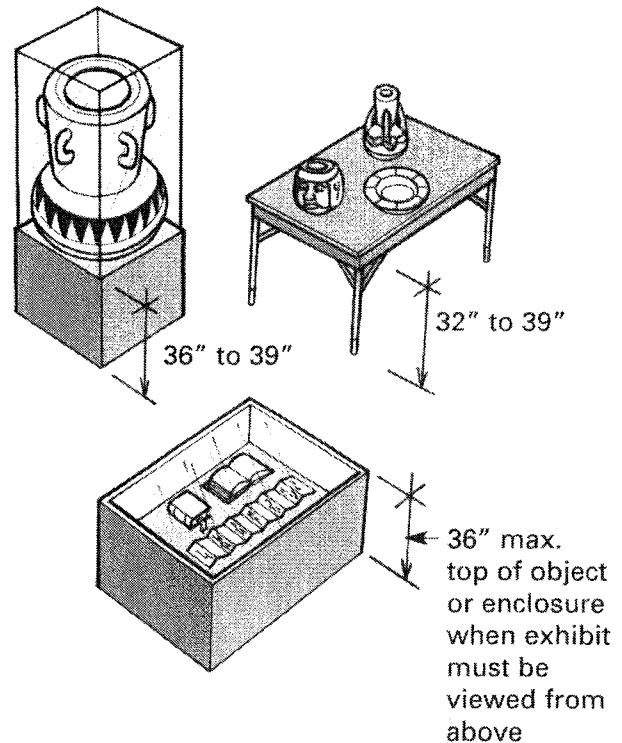

### Recommended Heights for Free-standing Displays, Cases and Tables

participants. Along with the availability of clear floor space, the height of objects dramatically affects successful viewing for seated people.

#### Free-Standing Displays

If objects are displayed on or in a free-standing case, ideally the bottom of the case should be mounted between 36 and 39 inches. Most people, including people seated in wheelchairs, those of short stature, and children, will be able to comfortably view three-dimensional objects positioned within this range. However, if objects are to be viewed from above, such as a flat book, the top of the object or any transparent enclosure should be no higher than 36 inches. It may not be pos-

sible to meet all of these criteria when displaying items on tables. As a general rule, try not to use surfaces higher than 36 inches and, if objects are intended to be viewed from above, lower is better. Mirrors, carefully placed, can also bring otherwise obscured surfaces into view.

If high display cases or bookcase style shelving are used, be prepared to assist people with disabilities. It may be necessary to take items out of cases or off high shelves so the interested person can view and study an object up close. This is particularly critical when items are for sale (see “Artwork, Crafts, and Other Wares for Sale,” page 69).

### Wall-Hung Cases and Objects

The bottom deck of wall-hung display cases should fall in the same 36 to 39 inch range as specified for head on viewing for free-standing displays. However, if incorrectly installed, wall-hung items can pose unique problems for people with vision disabilities (see “Eliminating Hazardous Protruding Objects,” page 57).

### Display Shelves

Space limitations often dictate that items be exhibited on vertical bookcase style displays, putting many objects above the preferred viewing height of 36 to 39 inches. This is especially a problem for seated people when the object is small and/or adorned with small detail. The best approach may be to place a representative sample of items in the preferred range and be prepared to bring items on high shelves to participants upon request.

### Display Panels

Display panels function much like movable wall panels and have the same protruding object issues as discussed in “Temporary Walls” earlier in this chapter on page 57. In general, there should be enough space to sufficiently back away from and closely approach the panel to view items displayed.

There is not a preferred range of heights to mount all flat images, i.e. photographs, paintings, maps, etc., as there are numerous variables involved: from the size of the image; to the lighting; and to space limitations within the display area. However, if the images are small or require

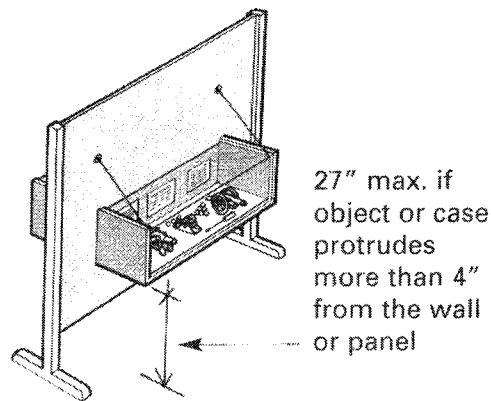

### Recommended Heights for Wall-hung Display Cases or Objects

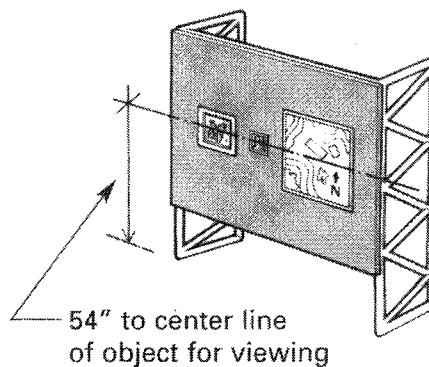

### Recommended Viewing Height for Small Images or Images That Require Close Study

close study, mounting the image with its center approximately 54 inches above the floor or ground surface allows both standing people and people who use wheelchairs to view the image comfortably.

### **Large Objects**

Large objects, or objects to be entered such as trucks, boats, or aircraft, pose unique problems to access. By their very design they are often difficult for many people with mobility disabilities or who are of short stature to either enter into or view the interior. Often the accessible route to the object on display cannot continue into the object without requiring significant modification of the object itself. Some objects cannot be altered, while others can be strategically placed to enhance viewing.

Some large objects may be of such a size or design, such as a yacht in a boat show, that providing access into it is beyond available resources. For many temporary events, the only practical solution is to provide a video "tour" of the object. Such video tours should be thorough enough to adequately convey an experience similar to that of actually physically entering the object. It also may be possible to provide a representative model showing key features or a life-sized mock-up to permit the participant to experience the key features of the object.

Where there are numerous objects on display, such as at a boat or antique car exhibit, it also may not be practical to provide physical access into all objects on display. A representative

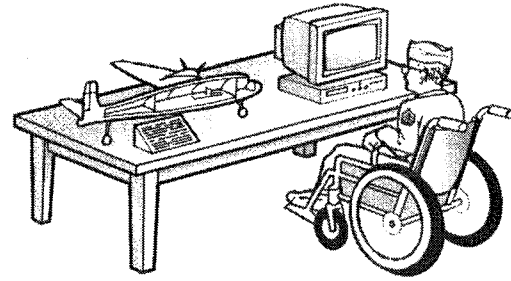

scale models and video tours

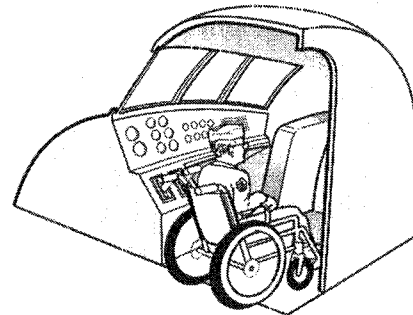

real size mock ups

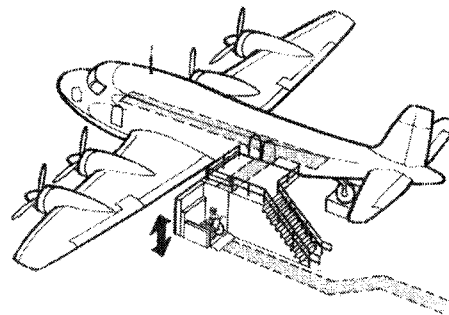

actual access to a portion of the object

### **Different Solutions for Large and Difficult to Enter Objects**

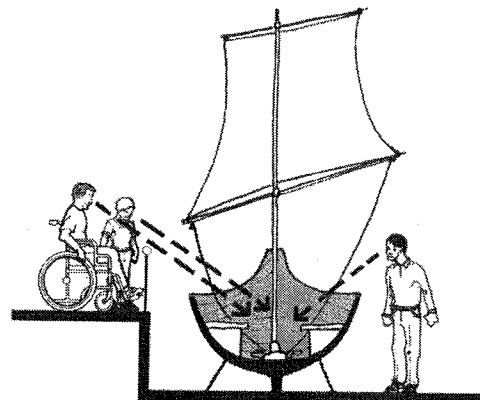

**Multiple Viewing Levels Allow More People to See Into Large Objects**

selection could be made accessible or again, video “tours” could be provided.

In exhibit spaces with accessible mezzanine or viewing balconies such as coliseums, it may be possible to improve viewing opportunities. Large objects can be strategically located so that parts of the object difficult to see from the main floor level can be viewed from an upper level.

### **Exhibits in Trailers**

As part of traveling carnivals and fairs, an entire exhibit is often contained in a trailer and participants enter the exhibit by climbing a set of three to five steps. Even though the accessible route up to the door of the trailer is difficult to provide, the content of the exhibit must be available to all participants. Vendors, at the very least, should provide a brochure of the exhibit for people who cannot enter. However, this will not be sufficient in the future. As time progresses, and exhibits are reworked, an accessible route should lead to the door and through the exhibit. The vendor should consider adding a temporary/removable ramp at the entrance or adding a lift. Either solution could become a permanent part of the necessary equipment that travels from site to site to display the exhibit.

### **Creating Access for People with Sensory Disabilities**

Exhibits and displays should be presented in a form that allows people with visual or hearing disabilities to obtain a full understanding of the content. Particular solutions may be influenced

by financial resources and the amount of time available before the event.

**Visual Disabilities.** People with visual disabilities can understand much about objects on display if they have the opportunity to touch and handle the object in a way that allows them to perceive its weight, texture, shape, etc. Duplicate or example objects can be offered for this purpose. Relief maps, which three-dimensionally project features, and scale models of large objects can also provide valuable information. If all people are allowed to touch these “tactile” exhibits, it makes the experience more educational and memorable for everyone attending the event.

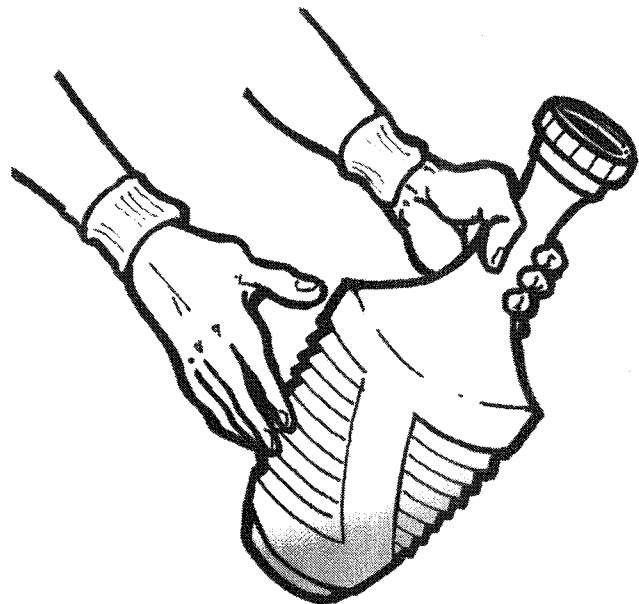

**“Tactile” Exhibits Can Be Touched and Handled**



Making the content available for items that cannot be touched, such as two-dimensional art, slide shows and video exhibits, must be considered. Try to plan such exhibits so a spoken narrative describing the content of the images is also provided. Exhibits for which the addition of an audio component for all to hear would not mesh with the goals of the exhibit, the content can be described on a separate audio cassette for individual participant use. Staff members can also describe images for a specific participant or if someone is explaining the exhibit to all participants, he or she can present a more detailed accounting so a person with a visual disability may acquire a full understanding.

**Hearing Disabilities.** People with hearing disabilities must have access to the content of audio/visual presentations, such as slide shows and videos. Ideally, such presentations would have captions or subtitles of the audio component. For an existing video, the spoken word could be presented in a written script and made available as needed. Where only ambient sounds are used, this should be noted so participants with a hearing loss know they are not missing a part of the exhibit.

### **Artwork, Crafts, and Other Wares for Sale**

How items are displayed for sale is critical. The ability to see, reach, and study objects or images is key to selecting an item to purchase. Ideally, a person with a mobility disability should be able to move about the vendor's entire display space.

Space limitations within the booth and the design of displays are common problems.

The recommended criteria to use for spatial layout when displaying items for sale is the same as for other exhibits on display. To review these requirements and solutions, see the beginning of the section on "Exhibits and Displays" earlier in this chapter, page 65.

Until a vendor can remedy such barriers or where display spaces cannot be modified, such as a mobile cart on a chassis, then an alternative method of providing the service must be offered so informed choices can be made. This may include taking items down from high shelving, bringing small items closer to an individual, or even carrying an object completely out of the display space and onto adjoining walks or into adjacent rooms.

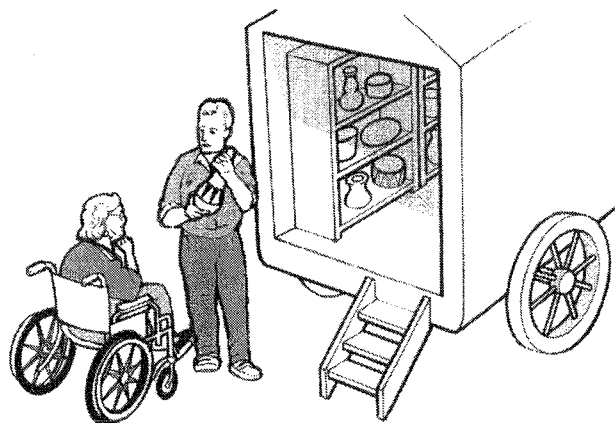

**Alternate Method of Providing Service**

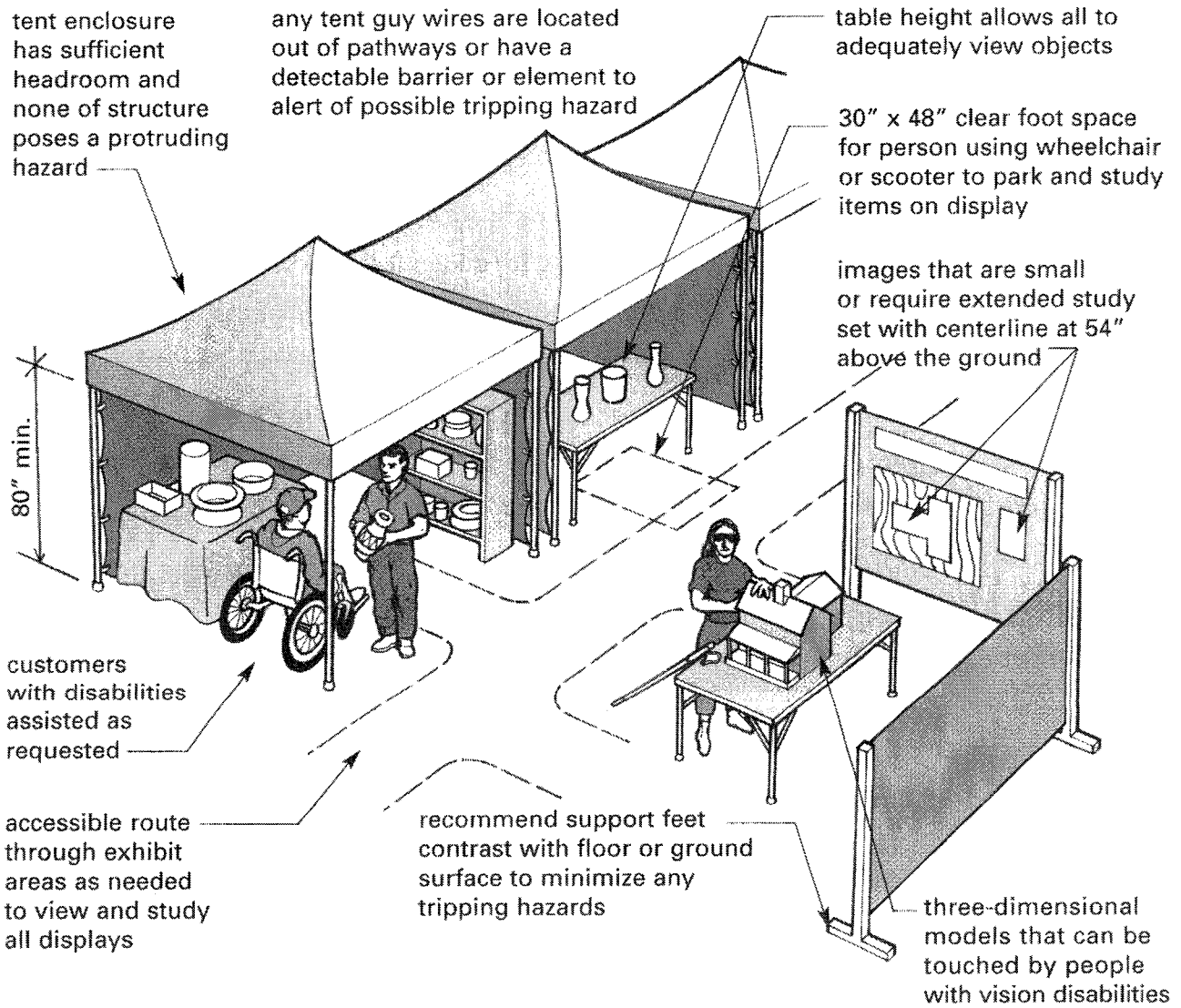

**Features of Accessible Exhibits**

**TAKING PART**

**Participatory Activities**

Many temporary events have activities that require or encourage the participation of event visitors. These activities may range from a simple question and answer session by a presenter to a more complex or free form task such as creating folk art. Common activities include games, competitions, workshops or impromptu speeches.

Inclusion is the emphasis for all activities. However, in some rare instances having separate divisions in an event will actually allow people

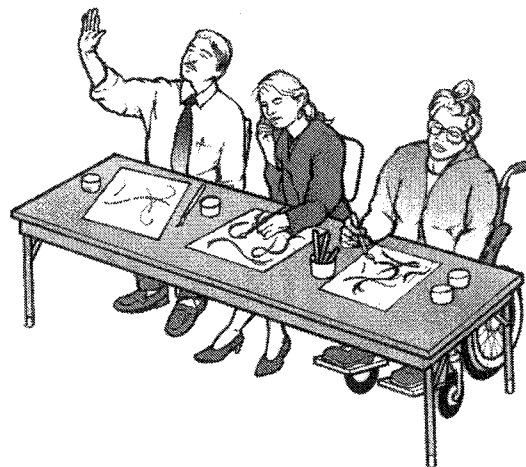

with disabilities to participate in a more equal manner. For instance, in a marathon competition having a wheelchair division separate from the men and women's divisions actually allows people with disabilities to participate with peers as other members of the community. However, many runners with braces or artificial limbs will want to compete in regular men and women's divisions. Having a flexible policy will allow participants with disabilities to choose the division in which they feel the most comfortable.

### Physical Accessibility

The level of access for people with mobility disabilities will vary with the nature of the activity. For example, a trampoline need not be eliminated from an activity because an individual with a mobility disability is unable to participate. However, there still must be an accessible route to the location so the individual may accompany

friends or supervise children. The issues for physical access are the ability to get to and around an activity and the design of tables, counters, or consoles. Additionally there are instances where the use of controls is critical.

**Surfaces.** For activities requiring a surface area, such as writing, painting, or model building, some tables or portions of counter tops must be accessible. The ADA Standards require that 5%, but never less than one of all fixed or built-in tables and seating, be accessible. This should also be considered a minimum goal for any work surfaces brought in for a temporary event. Adequate knee space must be provided beneath surfaces for people using wheelchairs or those with limited stamina who need to sit while participating in prolonged activities. Accessible activity surfaces also must be set at heights that allow people using wheelchairs to comfortably perform any necessary tasks.

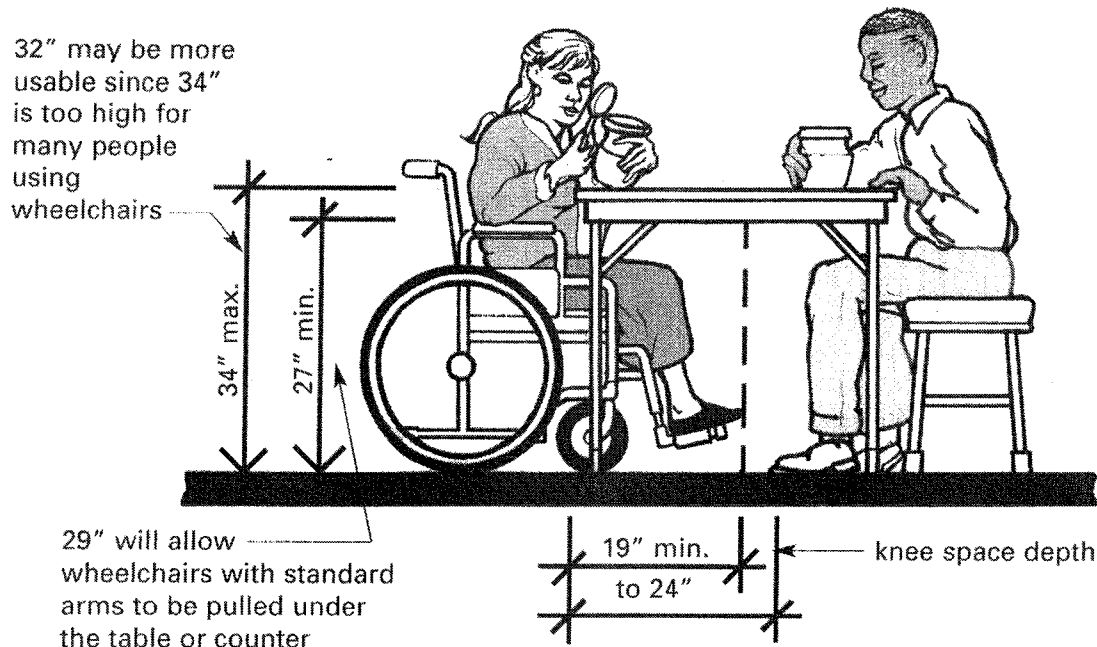

### Accessible Tables and Counters

For unique equipment or unusual work surfaces, such as a potter's wheel or an arcade game, access will be more problematic and particular to each situation. It is difficult to anticipate the variety of situations that may arise for such equipment. Where there are multiples of such equipment or work spaces, it may be possible to dedicate resources to make or acquire an accessible version to offer a representation of the experience. In some instances, assisting participants may be the only practical alternative.

***Exhibits and Displays with Controls.***

In addition to static exhibits and displays where the viewer primarily takes a passive role, there are other exhibits that solicit considerable participation, usually in the form of decision making and manipulation of controls. Such interactive displays should have controls that are usable by all people, i.e., levers, loop handles, push buttons, and rocker switches. These usually require little force to operate and are common enough that operation is intuitive for most participants.

Toggle or "joy stick" type handles and trackballs are also easy to use by people with limited hand function. These may be particularly useful for computer exhibits and can be used in conjunction with keyboards, as some people have difficulty making keystrokes. When it is not possible for all exhibits to have accessible controls, a few representative examples equipped with such controls should be provided to assure that a general sense of the experience is available for everyone.

where controls are provided at an exhibit and the user is expected to remain for some time, knee space should be provided



**Knee Space at Games or Exhibits with Control Consoles to Accommodate Seated Users**

**Eliminating Communications Barriers**

Communication barriers can be a critical issue as it is often the exchange of ideas, information, or experience that is the ultimate benefit of a participatory activity. These activities must be conducted in a manner that allows participation by people with disabilities that affect hearing, vision, or speech. Accommodations to achieve this need to be provided to the maximum extent reasonable.

**Hearing Disabilities.** For group discussions, workshops, or similar question and answer situations, a variety of approaches can work to accommodate people as needed. The key is for people to be able to understand presented information and have the ability to respond in as unrestricted manner as possible. For people with limited hearing, assistive listening devices that amplify sound could be kept on hand and used as needed. The most useful are portable systems that allow flexibility for small group or classroom situations (see “Assistive Listening Systems,” page 77).

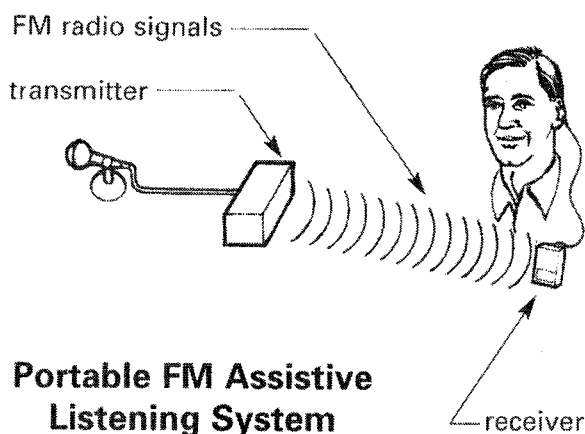

For many people with hearing loss, the use of sign language interpreters is essential for two-way communication to occur. While this may be impractical or costly for a single activity, it may be possible to have a pool of interpreters on hand for larger entertainment events that can be sent to activities as requested. There should be some scheduled accessible/interpreted performances for which advertisement has been made in advance of the event. Assistive listening devices also could be handled in a similar manner. In this way, resources can be targeted as needed. A registry of qualified sign language interpreters should be

available in your area, see Chapter 6: Resources.

Similar strategies also may work for game and competition situations or at exhibits with extended talks or audio presentations. If instructions are simple and response is limited, the use of pencil and paper may be sufficient.

**Vision Disabilities.** For people with vision disabilities, the ability to understand any visually presented information is the key issue. It may be necessary for people with limited or low vision to be physically close to visually presented information, instructions, or activities, e.g. maps, artwork, photographs, etc. For those for whom this will be ineffective or who are blind, additional explanations may be required of instructors and presenters so essential themes and facts are understood and the essence of the experience is conveyed. Where appropriate, sample objects may be made available for participants to touch and feel. Just as at exhibits, this strategy not only communicates more information to people with vision disabilities, but also can make the experiences richer for everyone.

**Cognitive or Developmental Disabilities.** People with cognitive or developmental disabilities also must be accommodated as much as possible for the activity offered. Keep instructions simple and presented in short sentences. Instructions for people with cognitive disabilities are more effective if participant action is required after each direction.

Attitudinal barriers still plague people with cognitive or developmental disabilities. Patience and a willingness to integrate everybody into the activities as much as possible is the best approach.

**TAKING PART**

**Assembly Areas**

Speeches, performances, and sports exhibitions are not only common integral parts of temporary events, but often the main activity or theme that draws people to the occasion. Regardless of the educational, social, or entertainment purposes of such an event, these are activities where a significant number of people will gather in a defined space. Such assembly areas, whether in permanent indoor facilities or temporary outdoor settings, must be accessible, both in the design of facilities and in how the program is offered.

Assembly areas without fixed seats, i.e., gymnasiums that rely on movable seating, large meeting rooms where furniture and stages must be brought in, and large open spaces where there may be no defined seating, are the major focus of this discussion. Eliminating communication barriers demands a higher degree of attention than may be required in other temporary events.

**Assembly Area Layout**

As with other areas and spaces, the placement of furniture or equipment, the availability of an accessible route, and adequate maneuvering space are critical. The layout of assembly areas significantly impacts the level of overall accessibility.

**Wheelchair Seating Locations.** The ADA Standards require that assembly areas with fixed seating, e.g. theaters, stadiums, etc., provide a range of built-in seating locations so people using wheelchairs can choose where to position themselves to view activities or performances.

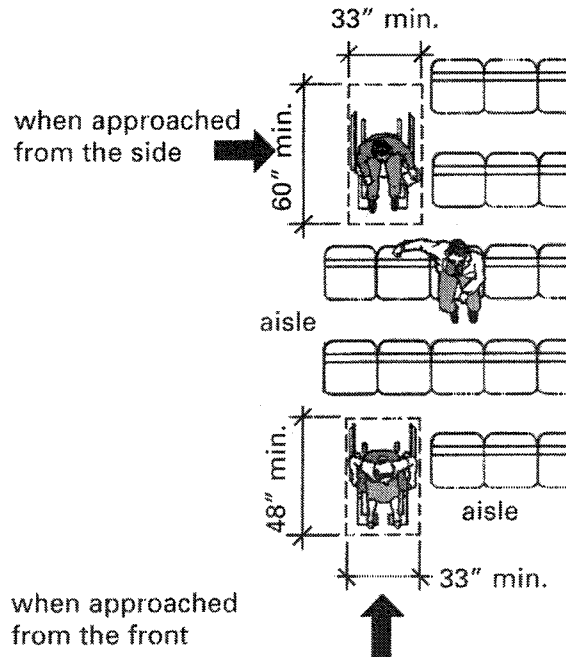

**Wheelchair Seating Location Size**

Capacity of Seating in Assembly Areas	Number of Required Wheelchair Locations
4 to 25	1
26 to 50	2
51 to 300	4
301 to 500	6
over 500	6, plus 1 additional space for each total seating capacity increase of 100

**Number of Wheelchair Seating Locations Required in New Construction**

The number of wheelchair locations required is related to seating capacity (see chart) and, with some exceptions, must be dispersed within conventional seating areas so patrons have a choice of ticket price. To the maximum extent possible, these goals also should be met or exceeded in assembly areas where moveable chairs are used for the temporary event.

Availability of wheelchair seating locations should be indicated and, if necessary, the spaces themselves designated. Although there is a

requirement for a “companion” seat with each wheelchair space, some locations should accommodate two people using wheelchairs to make it possible for two people with disabilities to attend the same event together. In many temporary situations, it may be possible to move tables or chairs as needed for event participants. However, accessible wheelchair seating locations should always be planned beforehand. Last minute changes are only acceptable as a method of improving usability or comfort for a particular individual, but not as an overall approach.

**“Classroom” Style Layouts.** In “classroom” style layouts, the placement of furniture is critical. At wheelchair seating locations there must be additional space between the rows of tables for maneuvering space and for a person using a wheelchair to pull up under a table so walking people and/or people using wheelchairs may pass behind.

**“Theater” Style Layouts.** “Theater” style layouts are commonly used for temporary events, particularly in large open areas where seating is not usually permanent, such as playing fields, large meeting rooms, and sometimes on the floor of gymnasiums and civic centers to supplement other fixed seating. Chairs can be set up in the usual manner, except that clear floor space must be allocated for wheelchair seating locations. Chairs can be strategically eliminated along aisles and at the back or front of seating areas to create spaces so people using wheelchairs can park beside other participants without obstructing pedestrian traffic.

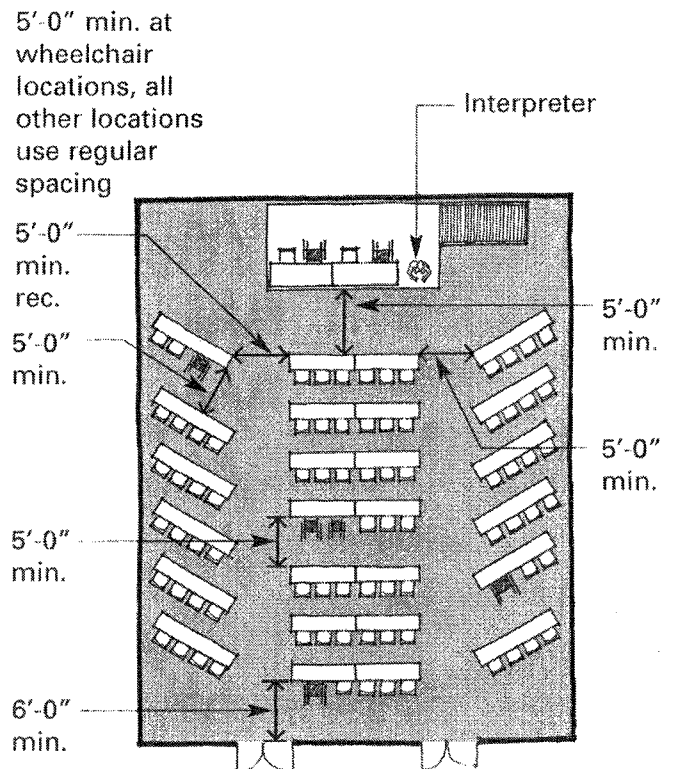

**Classroom Style Plan**  
(with loose tables and chairs)

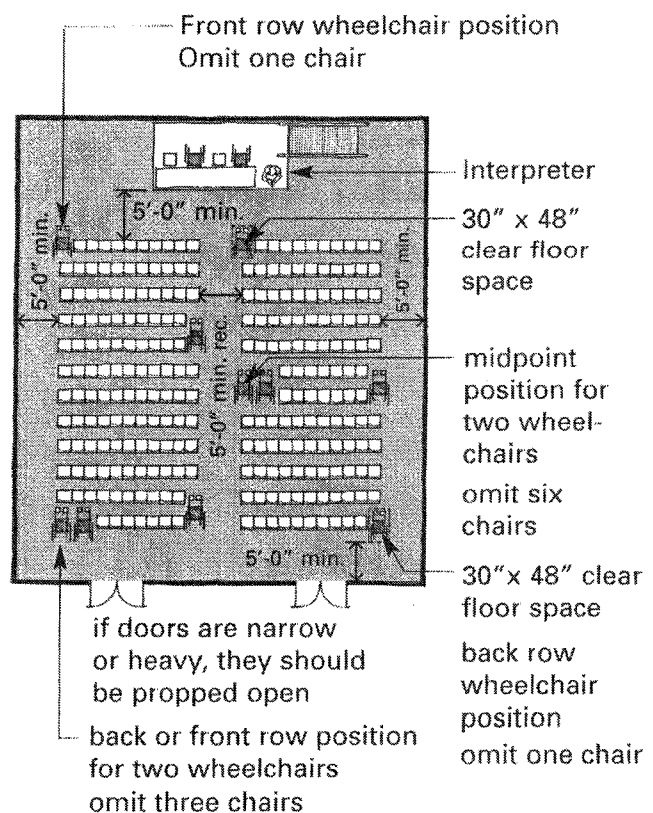

**Theater Style Plan**  
(with movable seating)

**Open Areas.** In situations where there is no fixed or temporary seating and participants are expected to sit on the ground, e.g. sloped grassy areas, it may be prudent to identify the most level areas and designate them as accessible seating areas. This is especially important when severe site conditions limit options and there are only a few areas where people using wheelchairs or scooters may safely park. These spaces should be held in reserve for a specified period of time before others may occupy those areas. Care also must be taken in the placement of cables, supports, and other stage or electronic equipment so accessible routes can be maintained.

**Access to Performing Areas**

Access to performing areas is an issue when there are performers or presenters with disabilities or when members of the audience may be expected to come on stage and participate in the presentation.

**Accessible Route to Performing Areas.**

Where performing and viewing areas are at different levels, it may be possible to create a direct

route between them using portable ramps or lifts (see “Changes in Ground and Floor Levels,” page 53). Where the audience will not go up to the stage, access for a performer or presenter may be provided via an accessible route through a backstage or other support area not used by the general public. When audience participation is anticipated, such routes are not ideal because it requires people with disabilities to take a route segregated from other participants. However, in many older facilities this may be the only realistic alternative.

**Speakers’ Platform.** A common arrangement for many events is to have several speakers present together at a single table. It is recommended that a speakers’ platform with a typical 30-inch wide table be a minimum of 8 feet wide by 16 feet long. This generally allows enough maneuvering room for people using wheelchairs and space for a sign language interpreter. To prevent speakers from accidental falls, place platforms against a wall to eliminate one edge. Locate tables and/or install a curb to eliminate

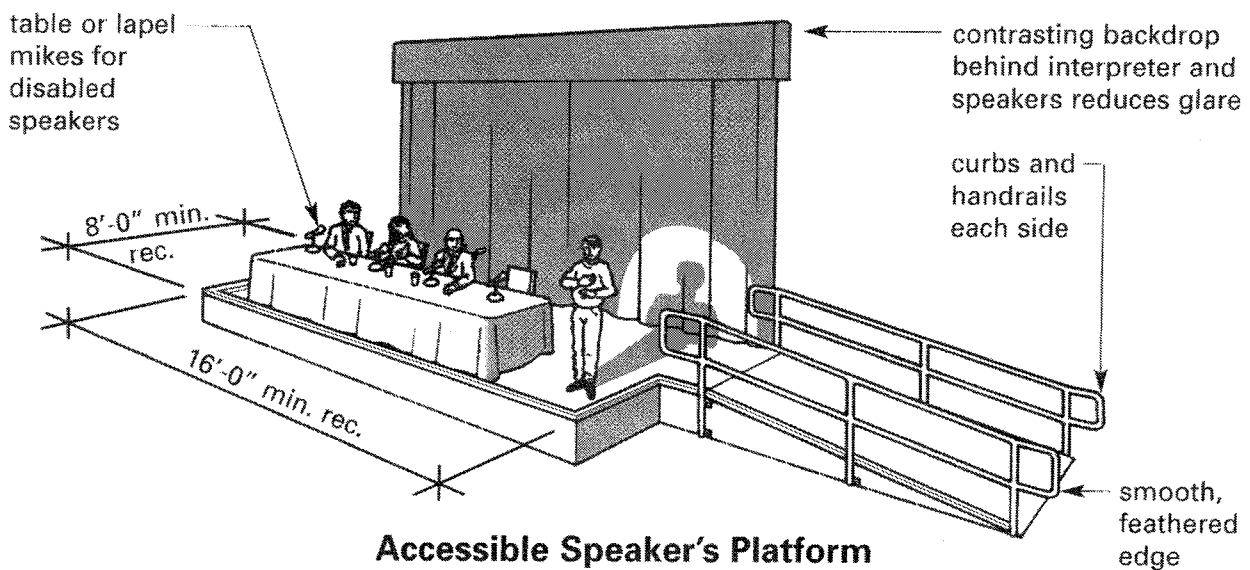



exposed drop-offs at remaining platform edges.

**Microphones.** Table microphones and lapel or lavalier mikes are best for people with mobility disabilities, especially people with limited use of their hands. Since some people may not be able to lean over tables to speak into mikes, it might be necessary to raise the mike by placing it on blocks. A mike stand with a horizontal boom is also effective for people using wheelchairs and scooters since it allows the user to get close with no knee space obstruction.

### **Eliminating Communications Barriers**

In assembly areas the ability to communicate the essential content of activities and presentations to all participants is critical. Eliminating communication barriers to people with sensory disabilities is a fundamental part of making the entire program accessible.

**Assistive Listening Systems.** People with varying levels of hearing loss make up a large percentage of the population with disabilities. The ADA responded in part to the needs of people with hearing disabilities by requiring listening systems at some seating locations in assembly spaces where audible communications are integral to the use of the space. These listening systems pick up voice/music directly from the source and then direct it to the listener who can adjust the volume to their needs. Most listening systems eliminate or reduce background noise so people with special receivers or their own hearing aids can adjust the volume and hear the sound more clearly.

Assembly areas that have fixed seating and accommodate 50 people or more, or have an audio-amplification system, must have a permanently installed assistive listening system. Other assembly areas must have a permanent system, an adequate number of electrical outlets, or other wiring to support a portable system. If the space being used does not provide these features, then other arrangements should be made for the duration of the event.

The minimum number of receivers for either permanent or portable systems should be at least equal to four percent of the total number of audience members, but never less than two. Receivers need only be available for the performance; so it may be possible to share the receivers between activities and presentations. The availability of the listening system should be indicated by signage using the international symbol of access for hearing loss (refer to "Accessibility Symbols" in Chapter 2, page 25). There are three types of listening systems currently being used: audio induction loop,

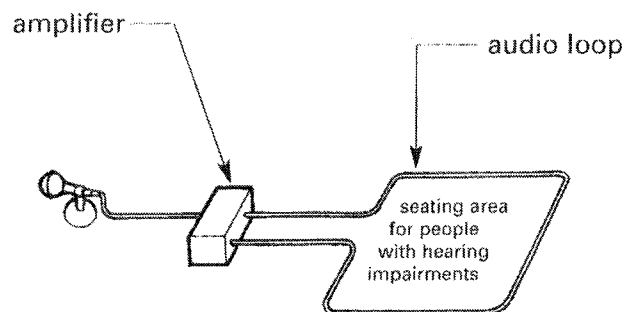

**Audio Loop System**  
(not used as much as in the past)

infrared, and FM radio transmission. An *audio loop* system consists of an amplifier and a wire antenna embedded in the floor or walls or simply taped to the surface around a designated seating area. It sets up a magnetic field that can be picked up by some users with hearing aids or others wearing a telecoil equipped receiver and an ear piece. There is a new technology known as a 3-D mat that has much less spillover and is less susceptible to electromagnetic interference. These systems are somewhat portable.

*Infrared systems* use light beams to transmit information to users wearing receivers with neckloops or headphones. Infrared systems offer confidential transmission, but, because infrared

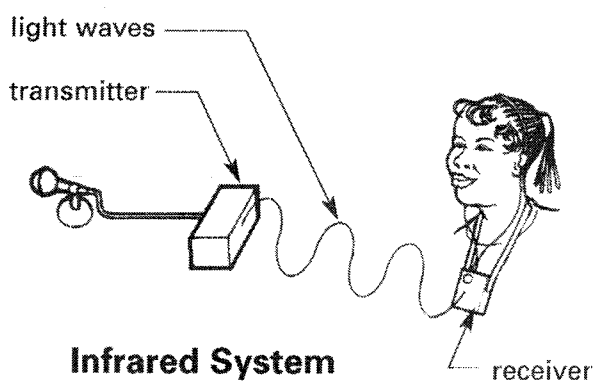

**Infrared System**  
(is used more frequently  
and generally in theaters  
and auditoriums)

light is present in natural and artificial lighting, well-lighted rooms sometimes produce interference. Infrared systems require an effective check-out system but can also be used in any seat in the facility, provided the seat has an unobstructed line of sight to the transmitter.

*FM systems* work similarly to the infrared but operate on FM radio frequencies, do not require an unobstructed line of sight, and are

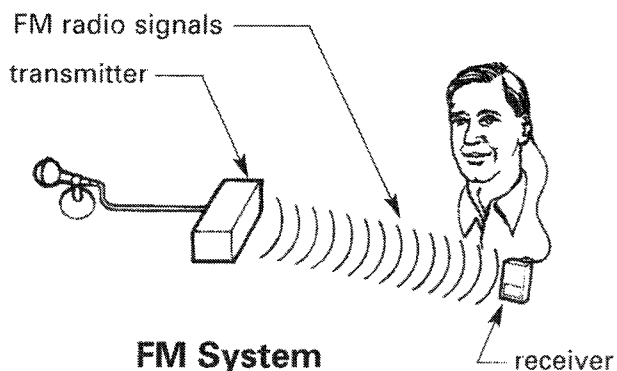

**FM System**  
(like infrared systems,  
FM systems are used more  
than audio loop systems)

unaffected by sunlight. However, where there are multiple events, different frequencies will need to be used. The FM system collects sound from either a microphone or public address system and then uses a transmitter to send the signals to small receivers. Hearing aid users with "T" (telephone) switches on their hearing aids wear receivers with a neckloop listening attachment which generates a magnetic field picked up by the telecoils. Other users must wear receivers equipped with earphones and a volume control to hear the amplified sounds. FM systems are portable and very reliable. Because FM systems require the user to wear a receiver and headset, they require a check-out or loan system.

**Placement.** If the listening system serves individual seats, the ADA Standards recommend that those seats be located within a 50-foot viewing distance of the stage or play area. At this distance, viewers can distinguish facial expressions and pick up other small gestures which help them interpret the actions of performers.

A wide variety of options and variables must be considered in planning effective and manage-

able listening systems for people with hearing disabilities. Manufacturers, organizations of people with disabilities, and service providers are good sources for additional information and advice.

**Sign Language Interpreters.** For many people with limited or no hearing, assistive listening devices are of little use. The use of a sign language interpreter is more advantageous, particularly for speaking presentations. Generally, an interpreter is located at the end of the speaker's table. An alternate location, that is sometimes preferred, is to have the interpreter on a raised step directly behind the speaker. A wide contrasting solid background should be hung behind the interpreter. This curtain eliminates the visual clutter in the background and makes it easier to see interpreter hand positions. There also should be an overhead lighting source to illuminate the interpreter. Audience members

with hearing disabilities must have an unobstructed view and, if necessary, be allowed to sit in front of the interpreter.

There are interpreters who are very good at mimicking the facial expressions and gestures of performers. Interpreter "actors" may work well for plays and stage productions to convey the full range of feelings and concepts inherent in an artistic performance. It may be possible that a selected performance of a particular work augmented with such interpreters could be scheduled and publicized ahead of time.

For a large event or conference, it may be impractical or costly to have interpreters for every presentation or performance; however, it may be possible to have a pool of interpreters on hand that can be sent to different activities as requested. In this way, resources can be targeted as needed. A registry of certified sign language interpreters should be available in your area, see Chapter 6: Resources.

**Text Display.** Displaying the content of presentations and performances in text is another method of access for people with hearing disabilities. Spoken narrative, song lyrics, or character dialog can be superimposed on a screen or displayed on a large monitor or on small individual screens. A variety of methods may be used including overhead projection, use of electronic text display panels, and in the case of audio/visual presentations, captions or subtitles.

It may also be possible to display the exchange of discussion panels or groups. However, in instances where there is no set dialog and discus-

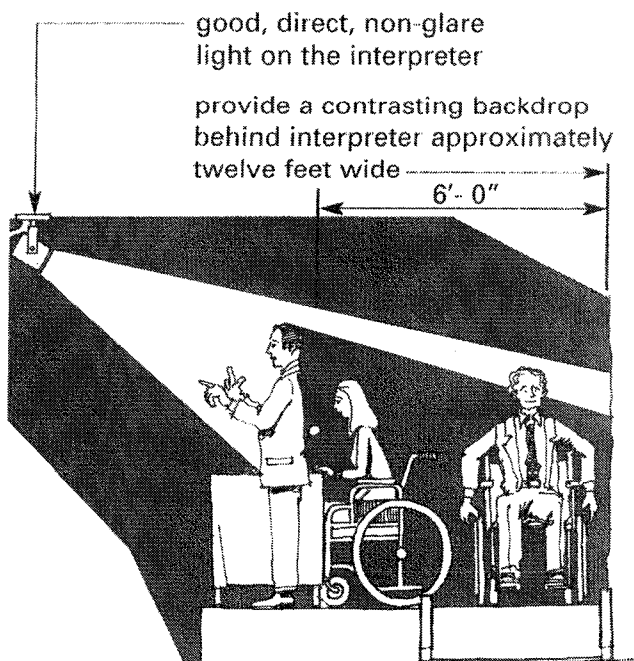

**Interpreter Position**

sion may be of an open forum, the use of computer-aided real-time reporting (CART) may be required. A stenographer types what is being said into a computer which then displays the text on a monitor or screen. While this is very effective, it can be costly and the event planner must review available resources and judge the appropriateness of this communication effort.

At least one showing of videos, films, or slide presentations should be accompanied with captions or subtitles of the audio track. Showings of captioned or subtitled presentations can be publicized ahead of time for those who wish to attend.

**Availability of Scripts or Text of Performance.** Another alternative for people with hearing disabilities is to make a script of the performance available so it can be read ahead of time or during the performance. While lacking a real time one-to-one relationship, this approach can be effective for complicated pieces of work, such as plays or operas. Where multiple works are staged, it is recommended that at least a representative performance be offered with accompanying text.

**Audio Descriptions.** For performances which are mostly visual in nature or where key information is visually presented, audio descriptions can be helpful for people with vision disabilities. Descriptions and explanations of visual elements could be recorded on audio cassettes and given out as requested. It is also possible that a one-to-one description could be provided where someone sits with a person who

is blind and voices descriptions.

**Seating Options.** Seating location will be helpful to many people with hearing and vision disabilities. Many people with limited vision can discern much in the way of color, shape, and movement if they can sit close to the performance. Likewise, people with hearing disabilities can effectively see the hand movements of sign language interpreters, displayed text, or the gestures of actors if they are close enough. Such visual cues, along with assistive technologies and services, can make a difference in an adequate understanding of content. Some seating in the front rows of assembly areas should either be held in reserve or accommodations made as requested.

## TAKING PART

### Games and Amusement Rides

**Games.** Games are typically offered at most fairs, carnivals, and street festivals. Such activities, by their very nature, are participatory and, should have the same level of both physical and communication access as established for other kinds of participatory activities. However, the most appropriate level of access possible for people with disabilities will vary with the nature of the amusement or game. Event sponsors and organizers should work with individual vendors to ensure the maximum degree of access possible and, at the very least, work toward making as many representative versions of games and amusements accessible as possible. Some games require certain minimum levels of physical ability.

For example, a game of ring toss or a turkey shoot requires the participant be able to see and be able to use one or both arms and hands. It is not anticipated that the game would be modified to allow someone who could not see or use their arms to participate. However, games must be accessible to the maximum extent reasonable.

High counters and railings that hold the participant back a prescribed distance from the game are common barriers. The mounting height of operable parts of equipment, e.g., water gun for a marksmanship game, should be considered. Often such heights are chosen because they work well for standing adults. Vendors should consider making at least one of the stations accessible. In addition to people using wheelchairs, it can make the game more enjoyable for adults of short stature and children who may not oth-

erwise be able to participate. Video and other arcade style games such as pinball function essentially like exhibits with controls (refer to "Exhibits and Displays with Controls," page 72).

**Amusement Rides.** Many carnival amusement rides are completely inaccessible to people with mobility disabilities and are presently difficult to make accessible. But some attempt should be made to create experiences for people with disabilities that allow active participation in at least some of the rides that may be easier to modify.

As new rides are created it is possible to make a higher percentage of them accessible. Even if no specific standards presently exist for amusement rides, the generic accessibility provision of the ADA Standards should be applied to the design of future rides to the extent possible. In addition, the Architectural and Transportation Barriers Compliance Board (the Access Board) has issued proposed guidelines that cover amusement rides. These can be used as guidance until final guidelines are developed and specific Standards are issued by the Department of Justice. If requesting these guidelines, refer to 36 CFR Part 1191 ADA Accessibility Guidelines; Recreation Facilities; Proposed Rulemaking. See Chapter 6: Resources for Access Board contact information.

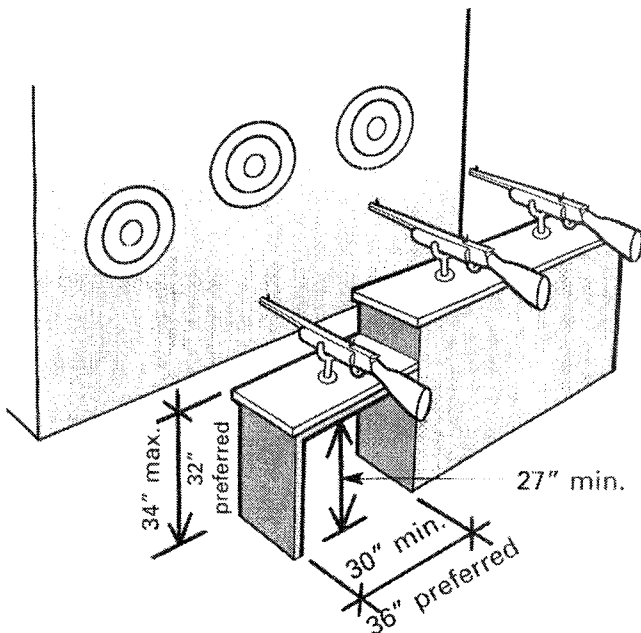

**Accessible Portion of Game Allows More People to Participate**

lower counter segment is easier for adults of short stature, children and those who use wheelchairs

**TAKING PART**

**Concessions**

Staple attractions at many temporary events are the refreshments offered for sale. Being able to purchase and enjoy food and drinks is certainly part of the total experience at most events. Both concessions offered by the event organizer and those offered by individual vendors should be accessible.

**Food and Drink**

The ADA Standards give specifications for accessible cafeterias, restaurants, and similar facilities that serve food. Many of the specifications for fixed facilities (restaurants, cafeterias, etc.) can be used in making temporary food service counters, trailers and tables accessible. A key specification from the ADA Standards is the height of service counters which must not exceed 34 inches. However, it may be difficult to provide service counters at this height when food and drink are offered from mobile trailers. A solution is to install a low folding shelf similar

lower shelf is also helpful to adults of short stature, children and people who have difficulty reaching

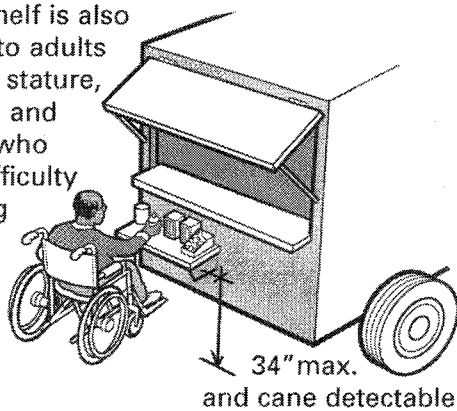

**Lower Auxiliary Folding Shelf**

to that suggested at ticketing/information desks (see “Information and Ticketing” earlier in this chapter, page 58).

While other accommodations may still be needed when actually serving food, condiments and menus can be placed on this auxiliary shelf within easy reach. It also may be possible for event vendors to jointly provide a condiment table in or adjacent to nearby eating areas.

**Eating Areas.** In addition, people with mobility disabilities should be able to reach each area provided for dining and be able to pull up under at least five percent but never less than one of the fixed tables. This necessitates the provision of an accessible route to the area and adequate maneuvering space around and under tables. This should be considered a minimum goal for any picnic or folding tables brought onto a site.

Where there are no tables near eating areas, consider providing one or two and some chairs. Such a courtesy will be helpful for many people with conditions that affect balance or stamina and who have trouble eating while standing or traveling.

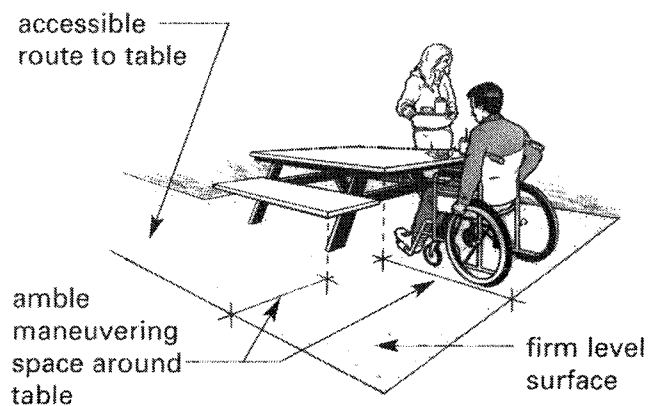

**Accessible Picnic Table**

## TAKING PART IN THE EVENT

*Locations for holding a temporary event span the gamut from a single room to an entire building and its adjacent site. An example of a convention center is used in this illustration because it contains the majority of accessibility concerns encountered when planning an exhibit, activity, or program. The information presented is applicable to most commercial and public buildings. The primary activity spaces shown are exhibits in lobbies and hallways, conference and small meeting rooms, ballrooms and mid-sized exhibit halls, large auditoriums, outdoor plazas and patios, general pedestrian circulation areas, and support facilities such as toilet rooms and parking.*

*The following numbered statements correspond to the numbers on the illustration.*

**1-** The low vertical clearance of parking garage does not allow entry by vans with raised roofs. Accessible parking should be located in adjacent parking lots or streets, as close as possible to entrances.

**2-** Accessible route from attached parking garage to interior of building provided when accessible parking is located on that level.

**3-** Temporary accessible parking spaces created from existing spaces. A temporary sign designates the accessible space.

**4-** Existing "accessible" parking spaces do not fully comply with the ADA Standards. The width of the spaces and access aisles is sufficient, however, their placement requires that a person travel in the flow of traffic to get to the nearest curb ramp. A new curb ramp could be installed or, if this is not possible, then a portable curb ramp and level wood walk to sidewalk could be provided.

**5-** Site sculpture is a hazardous protruding object. However, it is placed out of the main flow of pedestrian traffic and its presence is indicated by a low brick edge treatment that is both cane detectable and outside the main flow of pedestrian traffic so it does not constitute a tripping hazard.

**6-** Existing passenger drop-off area lacks a curb ramp. A portion of the area is blocked off and a portable curb ramp added.

**7-** Revolving doors are inaccessible. Auxiliary doors located adjacent to revolving doors can be used as the accessible entrance, even if assistance has to be provided. If no suitable door is at the main entrance, a service door can be used temporarily as an accessible entrance.

**8-** Some accessible parking spaces should be located in each parking lot or garage that is close to the building. However, some areas may have slopes or locations that make this impractical, requiring other arrangements be made for accessible parking.

**9-** Directional signage indicates nearest accessible route or entrance.

**10-** Portable, prefabricated ramps to overcome level change are strategically placed. Such ramps can be relocated to accommodate any changes in the pedestrian traffic flow.

**11-** Some temporary events take place on the exterior site as well as inside the building. Outdoor displays or activities must be accessible (sailboat display shown).

**12-** A second accessible route into building is planned using portable ramps. A sailboat is strategically located on the intermediate plaza level to take advantage of the accessible route.

**13-** Where permanent curb ramps can not be installed in time for the event, access over curb can be achieved by blocking off parking space and installing portable curb ramp.

**14-** Identify existing curb ramps so they can be used to advantage when laying out the accessible route.

**15-** Where none currently exist, installation of permanent curb ramps is the ideal solution but is rarely done for a temporary event.

**16-** Existing "accessible" parking space is not as accessible as one designed to meet the ADA Standards. To provide greater accessibility and usability, block off the existing accessible space and use it as the new, wider access aisle and designate the second adjacent space as the actual parking space.

**17-** Accessible routes provided to as many public transportation stops as possible.

**18-** When there is no parking on site, there should be accessible routes to the closest off-site parking garages and lots. If this is not possible, temporary accessible parking spaces should be created on the site.

- 19-** Existing entrance vestibule is too shallow for ease of use by participants in wheelchairs. Interior doors are propped open to allow additional maneuvering space.
- 20-** Portable lifts may be used to temporarily overcome level changes between intermediate floors or steps
- 21-** In locations where telephones are inaccessible, provide signage indicating availability and locations of a courtesy phone and TDD for people with disabilities.
- 22-** Signage on inside of building should indicate direction to accessible exit because this exit is inaccessible.
- 23-** Portable lift may be used to overcome level change between seating and speaking/performance area, particularly where there is insufficient room to install ramp.
- 24-** Stages, platforms or podiums are accessible and have adequate space available for interpreters to sign in a clearly visible area.
- 25-** Dark backdrop and adequate lighting ensure effectiveness of sign language interpreters.
- 26-** Dressing rooms and backstage areas are modified as needed for performers or speakers with disabilities.
- 27-** Portable seating must be arranged to provide accessible routes, accessible seating locations, and companion seating.
- 28-** Where an accessible route into a large display is not possible, then alternate access such as video and/or audio tape "tour" must be provided.
- 29-** Exhibits positioned to allow an accessible route through all displays and activities.
- 30-** Display elements that protrude into circulation path (here the bow of the speedboat) are surrounded by a detectable warning barrier that alerts a person with a visual disability. Stanchions with weighted bases are used to hold ropes.
- 31-** Signage, clearly indicating the accessible route between the levels (via the elevator in the lobby), is placed at bottom and top of stairs.
- 32-** Stairs with open underneath supporting structure reduce clear head room and are a hazard. Furniture or planters placed below are cane detectable and warn of hazard.
- 33-** Information displays and booths should be accessible with all information readily available.
- 34-** Upper levels of display areas must be accessible if same information and events are not offered on lower levels. Elevated area allows viewing of displays from above – a real advantage for many people.
- 35-** Informational signs indicating agendas and schedules produced in large, high contrast easy-to-read characters.
- 36-** When existing public elevators are insufficient in size to accommodate people using wheelchairs, freight or service elevators may serve as a "get by" method of access. Assistance may be necessary in operating such elevators.
- 37-** If brochures indicating agendas and schedules are provided at information tables, some should be prepared in large type.
- 38-** Accessible information kiosk has low counter.
- 39-** Most escalators are not accessible. Alternative accessible routes must be planned.
- 40-** Open space below escalators has reduced head room. Furniture or planters placed underneath provide a cane detectable warning and prevent head injuries.
- 41-** Ideally exhibits offer their content in a way that it is accessible to people with mobility and sensory disabilities.
- 42-** Furniture placement in lobbies should allow accessible routes and wheelchair spaces in sitting areas.
- 43-** Self-service food buffets tables and service counters are accessible.
- 44-** When existing drinking fountains are protruding objects, planters or furniture can be placed to redirect the flow of traffic around them. Additionally, if fountains are too high, as a temporary solution, paper cup dispensers can be installed adjacent to the inaccessible units.
- 45-** An accessible route is provided throughout room. Some conference tables are accessible to people using wheelchairs or other mobility devices.
- 46-** Speaker stands and podiums are accessible. Dark backdrop and appropriate lighting enhances interpreter effectiveness.
- 47-** Vestibules to toilet rooms are too small for people using wheelchairs. Doors may be removed or left open to increase room for maneuvering.
- 48-** If a toilet room is inaccessible, provide signage indicating the location of the nearest accessible toilet room. All toilet rooms should be modified to provide as much access as possible.
- 49-** Existing toilet stalls that are too small may be improved somewhat by removing doors and/or partition walls to increase maneuvering space.
- 50-** Other toilet room modifications include insulating pipes, placing bar soap and paper towels on countertop, and adding a full-length mirror.



# TAKING PART IN THE EVENT

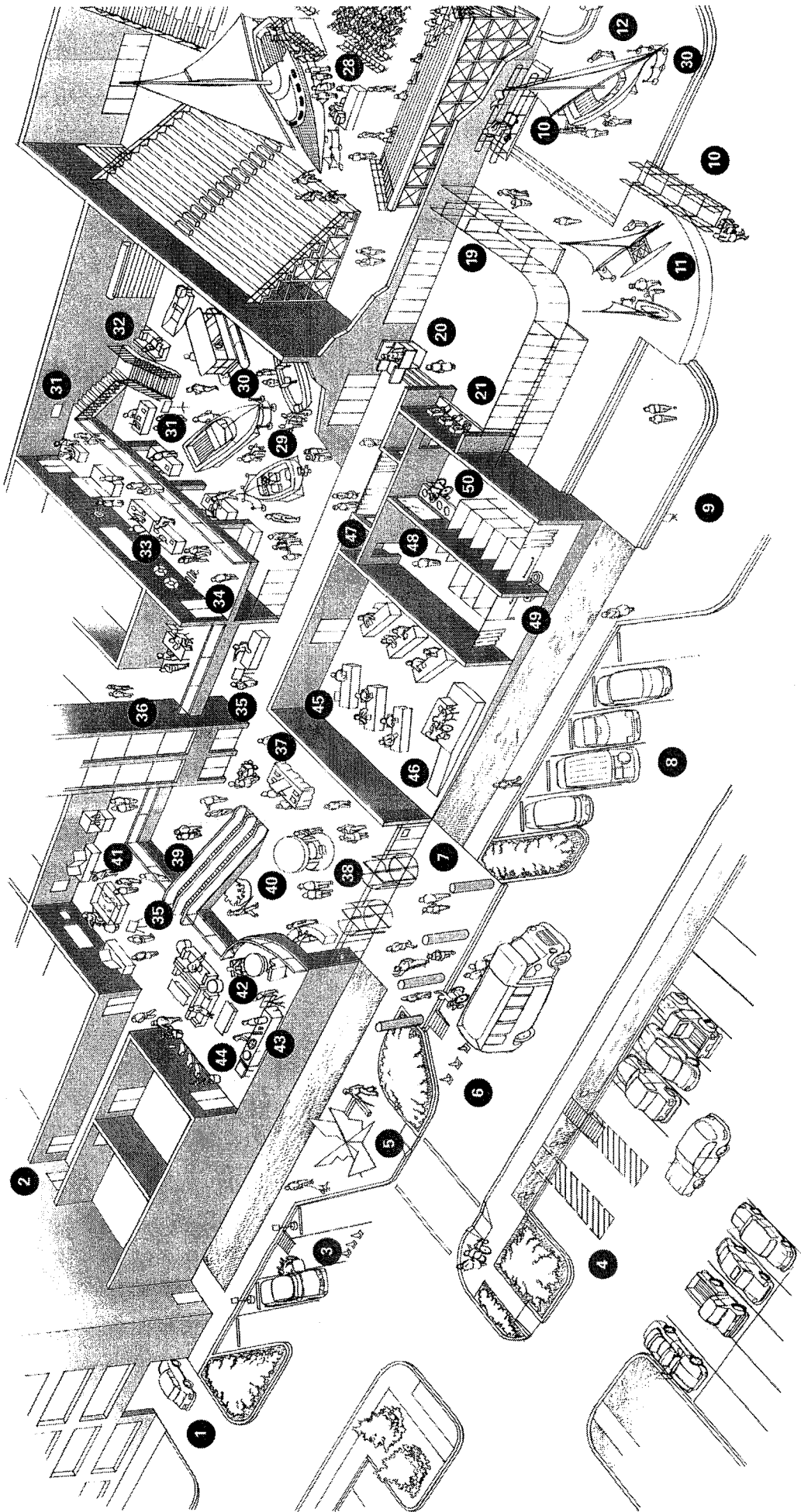

ACCESSIBLE TEMPORARY EVENTS

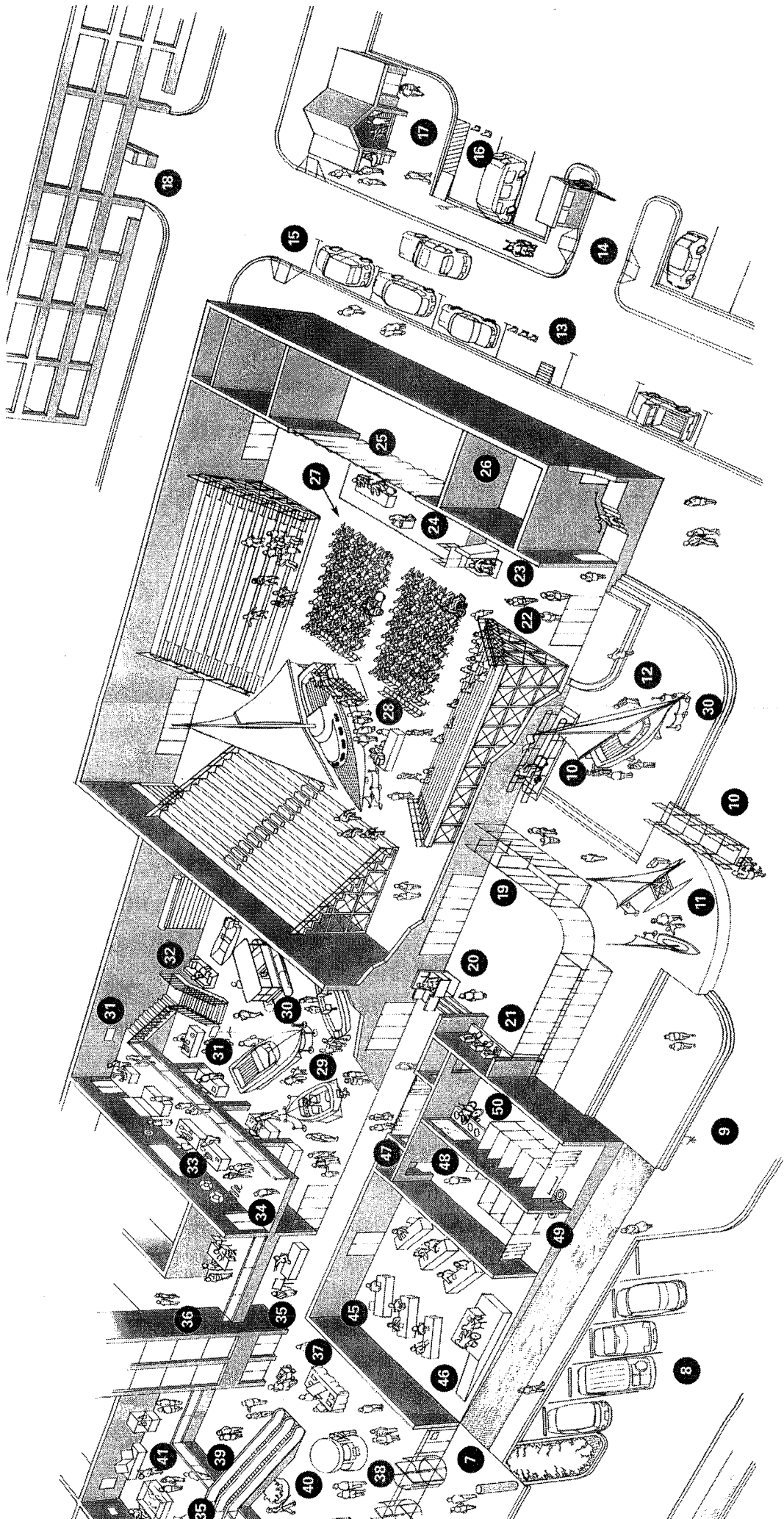

## **INTRODUCTION**

Support services and amenities, although not the primary draw or appeal of a temporary event, when provided, not only make participation in an event comfortable but, for many people, they make it possible even to attend at all. When a temporary event is being planned and specific amenities are to be provided for the general public such as restrooms, telephones, and drinking fountains, they must be provided in an accessible manner to offer people with disabilities an equal opportunity to enjoy the event.

For a temporary event, total accessibility is not always possible. It might be necessary to creatively provide accessibility, for example, by making temporary modifications to an existing permanent restroom, adding accessible portable toilet units, or adding a paper cup dispenser at an inaccessible drinking fountain. Whenever planning an event, it also is important to consider, in addition to access to restrooms, telephones, and drinking fountains, providing shelter from the elements at an outside event, providing potable water on the site (especially if drinking fountains are nonexistent or remote), and ensuring that some form of first aid services are available.

A note of reassurance: Although it is perhaps true that some people with disabilities have greater than average medical needs, event organizers generally need not be concerned about them beyond assuring that there are emergency medical services available that can be called if necessary—

a precaution that should be taken for any group. However, in all cases, if a person with a disability is having physical or medical difficulty and is able to communicate, ask the person directly what is the most appropriate course of action. Never assume you know what is best for that person.

The remainder of this section addresses each of the topics of “Toilet Facilities,” “Drinking Water,” “Shelter,” and “Telephones,” and gives guidance on providing both temporary and sometimes permanent solutions to accessibility problems. Any permanent solutions that can be completed are one less concern that will not have to be addressed when planning the next event.

## **TOILET FACILITIES**

Access to toilet rooms is a critical issue that determines to a large extent how much a person with a disability can participate in programs and activities. Without appropriate toilet facilities, many people have a limited amount of time that they can be away from home.

Every toilet room available to the public should have at least one toilet and lavatory fixture that is accessible to people with disabilities. However, this may not be a realistic expectation for older facilities. Modifications need to be made to the greatest extent possible, but it may be difficult to provide full accessibility into many existing toilet rooms. It even may be necessary to rely on accessible facilities in adjacent buildings

or sites. If this is the case, directional signage to these accessible toilet facilities is critical.

Portable toilet units, also known as port-o-lets or port-a-potties, are one of the few components of temporary events that are specifically covered by the ADA Standards. The Standards require that five percent of the units must be accessible and provide specifications for the design of the units. The number and design are discussed later in this section (see "Portable Toilet Units," page 93). Depending on the nature of an event, it may be possible to use accessible portable toilet units to compensate for inaccessible permanent facilities.

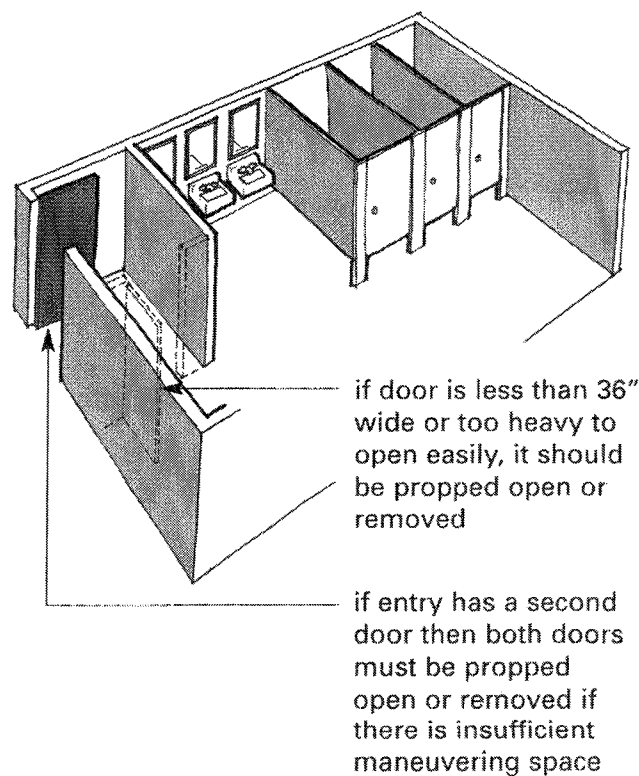

### Toilet Room Doors and Vestibules

Doors should provide a 32-inch clear opening to accommodate people using wheelchairs and other mobility aids, see page 55. If a door can stand open and not require users in wheelchairs to push against the weight of the door as they enter, many people can get through an opening as narrow as 28 or 30 inches. If toilet rooms have privacy screens or vestibules where the door can stand open and yet privacy is still maintained a simple step such as propping the door open or removing it altogether may suffice.

Where leaving doors open will compromise privacy, a temporary privacy screen can be installed outside the room. Standard exhibit booth curtains are useful for this purpose.

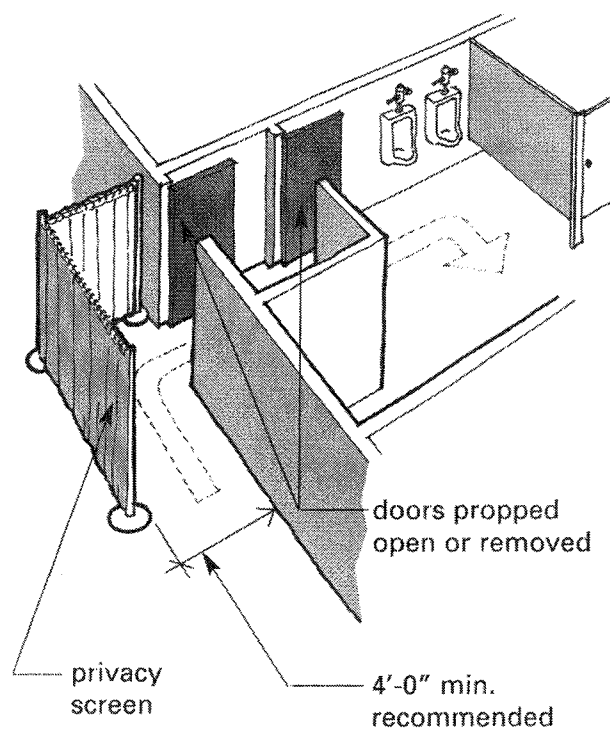

### Toilet Room Vestibules

**Toilet Room Clear Floor Space**

Toilet rooms to be usable must have enough clear space inside to allow someone in a wheelchair to turn around to exit the room without backing out. A 5-foot diameter clear floor area will provide the necessary space, see page 46. A 3-foot wide T-shaped clear floor area will also suffice and allows for a three-point turn, see page 46.

If toilet rooms do not have enough space for one of these maneuvering areas, it will not be usable by many people in wheelchairs. Sometimes just removing or relocating free-standing objects, such as trashcans, may help free up floor space. Generally, modifications that increase maneuvering area must be of the type that are permanent, i.e., removing or rearranging stall partitions or creating knee space under lavatory counters. It may be necessary to look

at other toilet spaces in the facility or in adjacent areas and direct people as necessary.

**Toilet Stalls**

Ideally, multiple fixture toilet rooms will have at least one 60-inch wide accessible stall as required in new construction. This type of stall should be relatively common since it has been specified in several of the design standards for accessibility that appeared prior to the development of the ADA Standards.

Such stalls are the most usable by people in wheelchairs and who use scooters. There is just enough clear floor space available to maneuver about the toilet fixture and/or to allow an attendant to assist in transfers, if necessary. Grab bars are located in positions to be of most use for transfers on and off the toilet and stall doors are easy to open and pass through.

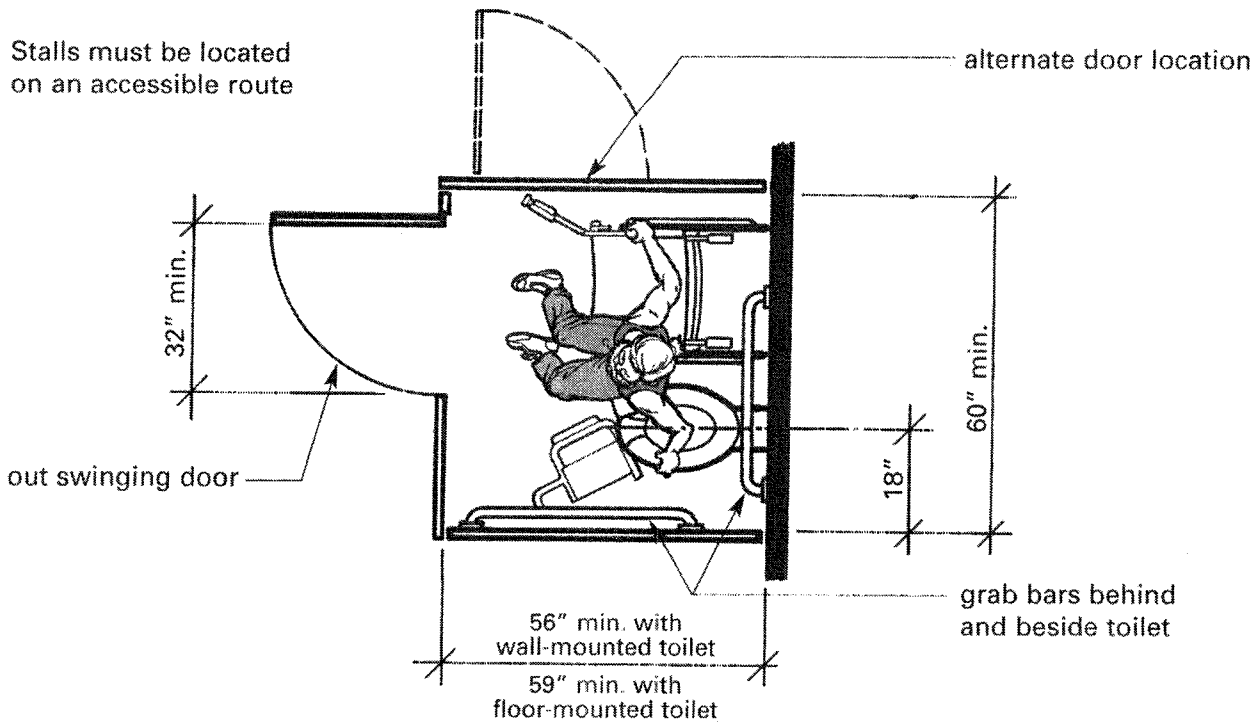

**Standard Accessible Stall**

If a 5-foot wide stall does not exist in a toilet room, there is no practical way to furnish one temporarily. However, a wide stall may be created by combining two conventional sized stalls and removing one toilet fixture. This does require permanent modifications such as the installation of new partitions and grab bars and the repair or replacement of floor and/or wall coverings.

While it may be difficult to provide a standard accessible stall, there are modifications that can be undertaken more easily to improve existing narrow conventional stalls that can be done as part of “barrier removal” efforts. This is permissible only for Title III entities (private businesses and nonprofit service organizations) where it is not “readily achievable” to meet the design requirements of the ADA Standards (see “Modifications to a Site” in Chapter 2: “Advanced Planning,” on page 19). The recommended steps for improving the usability of a narrow stall are:

1. Select a stall against a wall — preferably at the end of a room or row.
  
2. Install 40-inch minimum length grab bars on each side of the stall 33 to 36 inches above the floor. These must be well anchored to support a 250 lb. load in all directions. This is a permanent modification that should be requested of the building owner.

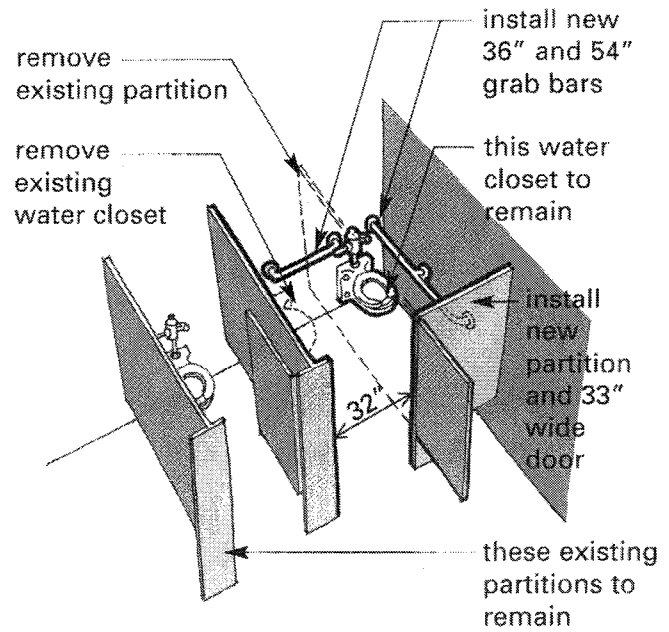

**Combine Two Conventional Stalls to create an Accessible Stall**

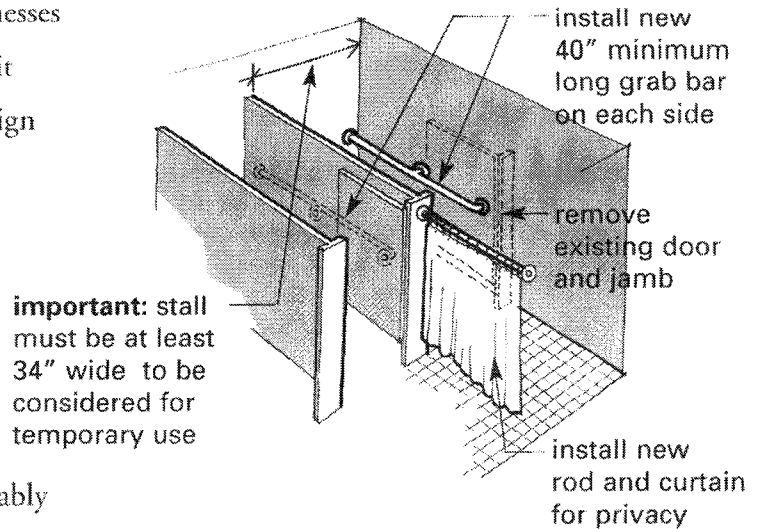

**Permanent Adaptation**

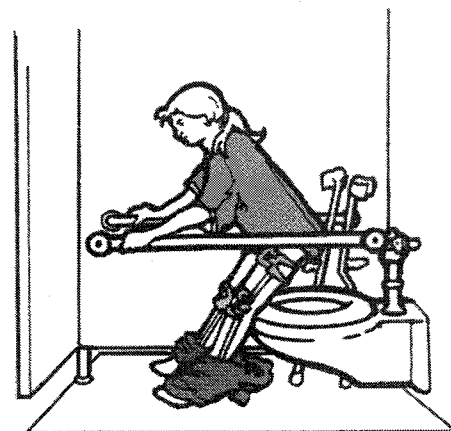

**Use of Parallel Grab Bars**

3. Remove existing narrow door and wall side jamb.
4. Install overhead rod and privacy curtain.

Only a small minority of people in wheelchairs may actually be able to use such modified stalls. People who walk with the aid of crutches or canes find this narrow stall very useful because the close parallel bars are available for support when sitting down and rising. In fact, in toilet rooms with six or more stalls constructed since the implementation of the ADA, the installation of a 36-inch wide stall is required in addition to the standard accessible stall.

### **Lavatories, Mirrors, and Dispensers**

Lavatories to be accessible to people using wheelchairs should have a 29-inch clearance between the bottom edge of the apron and the floor. Faucets should have handles that can be operated without grasping and twisting — lever and wand types are good choices.

Mirrors should be mounted so the bottom edge is no more than 40 inches above the floor. Depending on the direction of reach, dispensers should be no higher than 48 inches unless located over a counter or fixture where they are limited to 44 inches above the floor. Whenever any of the existing conditions vary from these parameters, some simple steps can be taken to make the existing fixtures more readily usable.

Smooth round faucet knobs should be removed and replaced with lever handles or other shape, operable without tight gripping. Countertop

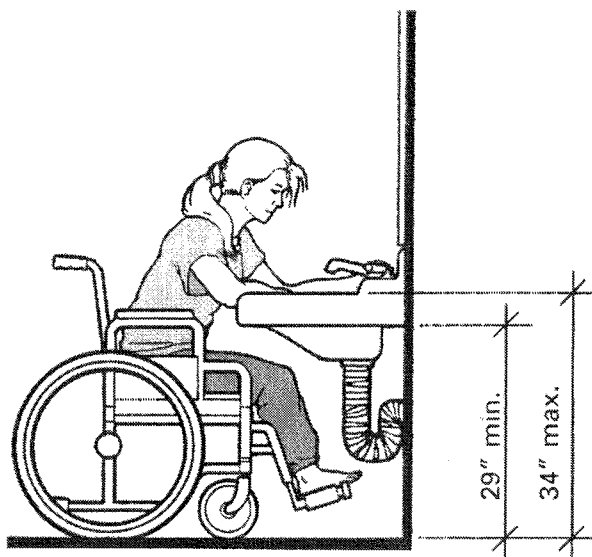

**Knee Space Permits a Close Approach to the Lavatory**

aprons made of materials such as synthetic marble can be cut back to provide the necessary knee clearances. It is recommended that exposed hot water pipes under all lavatories be insulated to prevent burns on the legs of people using wheelchairs. This must be done for the accessible lavatory.

Where towel dispensers and mirrors are too high, it is usually less costly and quicker to mount a new towel dispenser nearby and install a full-length mirror on another wall than it is to relocate existing ones. The full-length mirror is good for everyone to use.

A temporary solution to the problem of towel height is simply to place some towels on a shelf or table within reach of seated or short people. A good, inexpensive, temporary solution to a soap dispenser height problem is to make regular cake soap or pump bottles available. Additionally, any freestanding trash receptacles should be located so they do not interfere with wheelchair maneuvering space.

Many people who use wheelchairs can, with difficulty, use a lavatory that does not have the standard 29-inch minimum clearance under the apron. For this reason, it still is prudent to

undertake the above cited modifications and temporary measures even if this clearance cannot be provided.

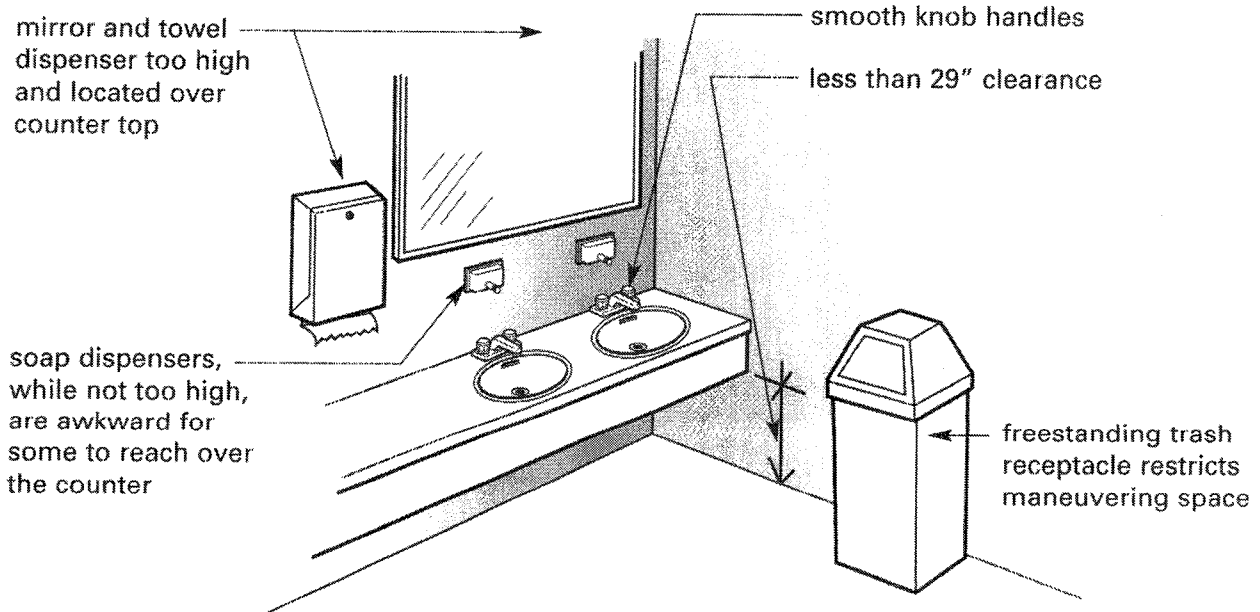

**Typical Problem Lavatories**

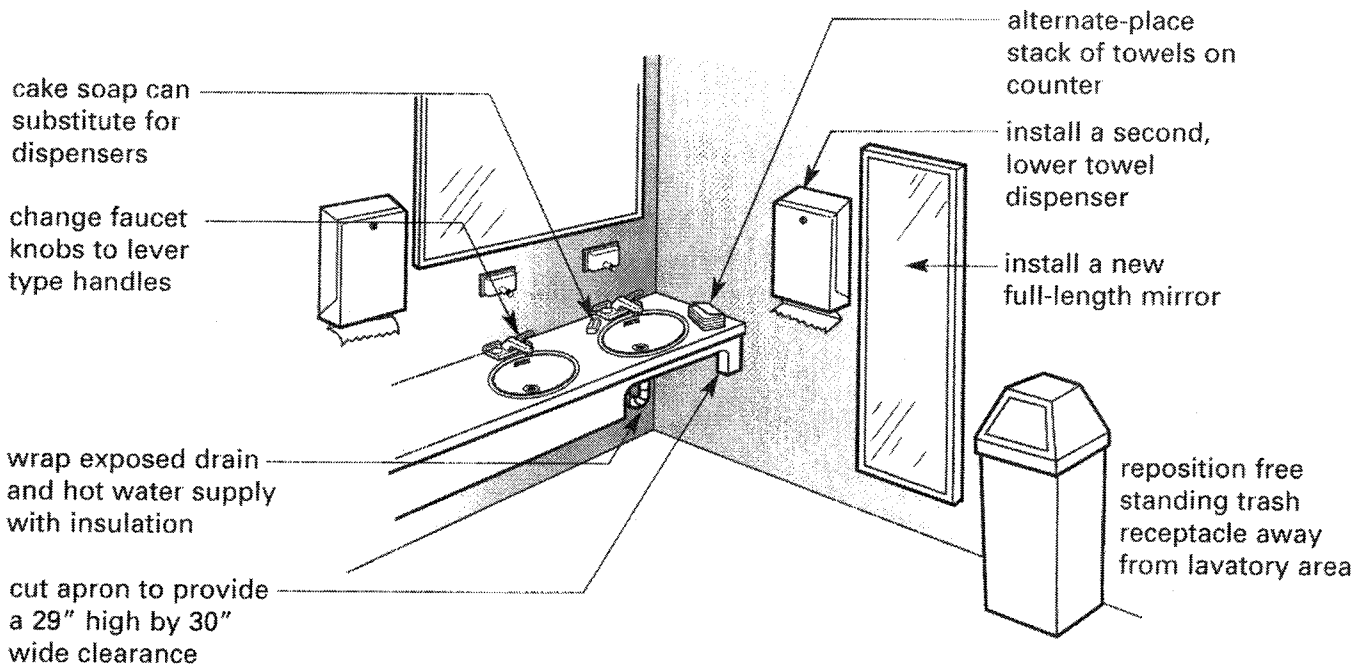

**Problems Solved**



### Single-User Toilet Rooms

On sites that lack adequate accessible toilet facilities, a good option is to create a new accessible single-user or unisex toilet room. While beyond the scope of modifications required for a temporary event, this is an excellent long-term cost-effective solution. For large sites with multiple buildings, it may be possible to centrally locate a freestanding accessible toilet room. Presently, there are manufactured single-user and small public toilet rooms available that incorporate accessibility requirements into their design.

### Portable Toilet Units

If portable toilets are provided for use by event participants, a minimum of five percent, but **never less than one unit**, of all units must be accessible. However, the total number of accessible toilets that must be provided on the site may actually be higher. Where clusters of portable units are provided at various locations around the event site, at least one unit in **each** cluster must be accessible. They should be equipped with all the accessible elements required by the Standards such as maneuvering space, grab bars, toilet paper dispensers within reach, etc. In addition, when all units are not accessible, the International Symbol of Accessibility must be posted on the units that are.

For increased usability it is recommended that 36" is provided between the toilet and lavatory.

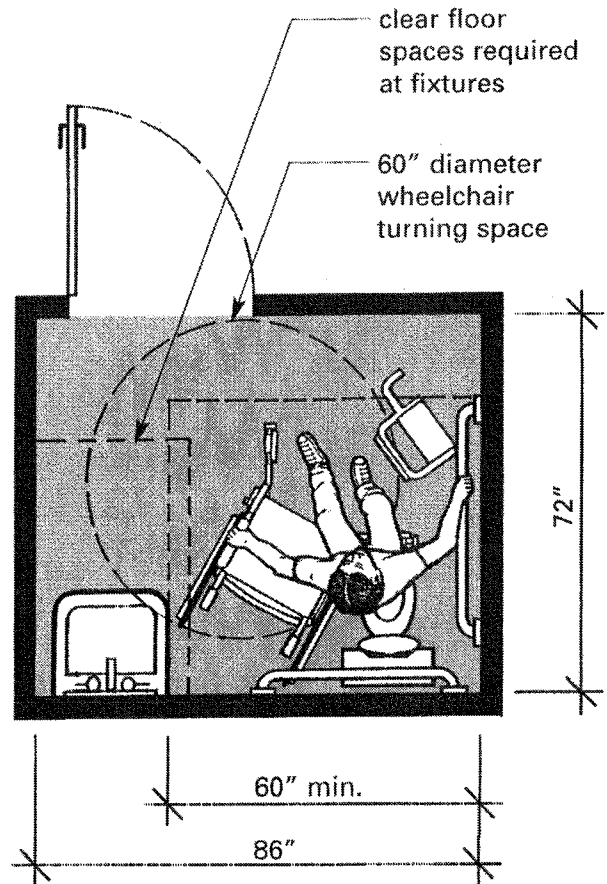

**Recommended Single-User Toilet Room**

Portable toilet units presently are being manufactured that meet all of the specifications of the Standards. However, care must be taken in the selection of an adequate model. Some portable toilet units promoted as accessible do not contain sufficient interior floor space. Some also make use of a ramp that slopes directly up to the entrance door making it difficult or impossible for people in wheelchairs to climb the ramp and pull the stall door open at the same time. While these units are helpful to some people, they still are not accessible to many others.

Equally as important as the design of the accessible unit is its location and placement. It must be positioned on a level area that connects

with an accessible route and have adequate space just outside the entrance door for people in wheelchairs to maneuver into position to open the door and enter. On steeply sloping sites, a temporary platform may be needed to provide this level area.

Attention also must be paid to the door threshold. Outdoor surfaces are often uneven, thus, be prepared to add a small bevel to level out the transition between the ground surface and door threshold. Many problems with sloping and uneven ground surfaces diminish if units can be placed on or adjacent to parking lots or other paved surfaces. Make sure, however, that there is adequate room in which to safely maneuver a wheelchair around any waiting lines at other toilets.

best if units can be located adjacent to or on a paved or compacted earth surface

unit has all typical toilet accessibility features such as grab bars, space to the side of toilet and so forth

there must be adequate room for a person using a wheelchair to turn around and exit the unit

when clustered with conventional inaccessible units, the accessible one must be designated with the international accessibility symbol

level clear ground space to maneuver at door

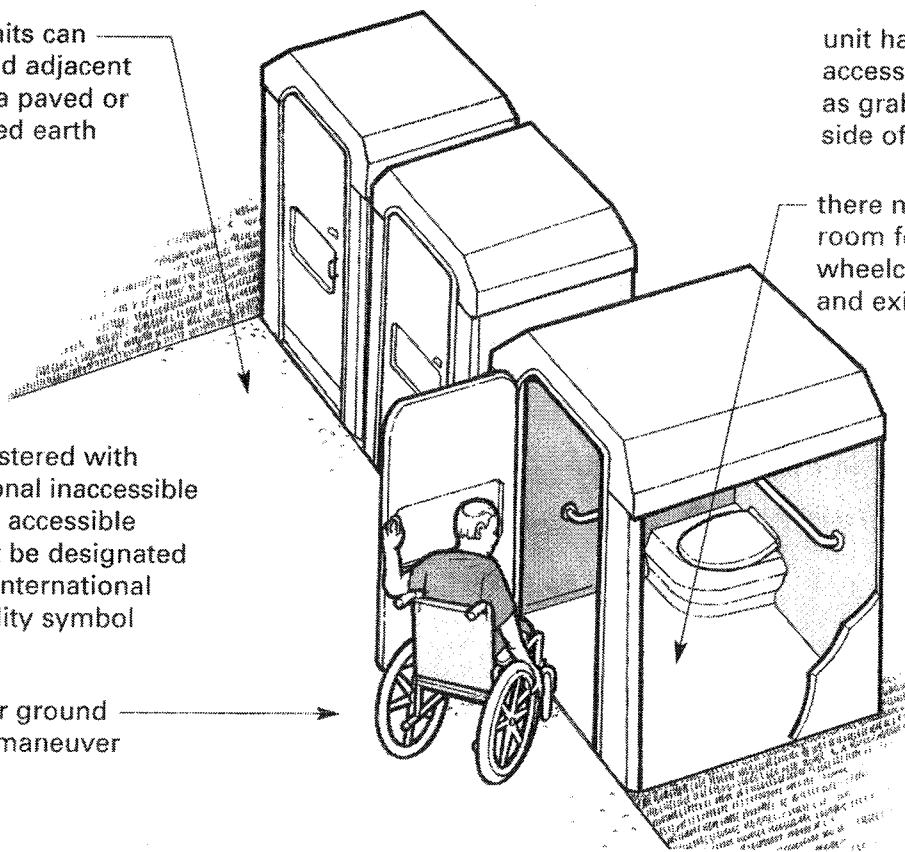

**Accessible Portable Toilet Unit**

**AVAILABILITY OF DRINKING WATER**

Drinking water should be readily available to all people, but particularly for some people with disabilities who must drink fluids regularly and/or are susceptible to dehydration or becoming overheated. Consider the duration and size of the event and evaluate the adequacy of existing drinking fountains. Availability of water may be of secondary concern for small brief meetings but is critical for large or lengthy events.

In the case of concessionaires who offer soft drinks and juices, they also should provide water. If only a few or no drinking fountains are available, consider adding portable water containers or coolers placed in easy-to-find accessible locations, e.g., at information/courtesy booths. Controls to release water should be easy to use and require little hand pressure. Latches and levers are preferred while push buttons should be avoided.

**Drinking Fountains and Water Coolers**

If drinking fountains are available within a building or on the site used for a temporary event, ideally, there should be some “high” drinking fountains for taller standing people or people who have trouble bending over and “low” fountains for children, people using wheelchairs, or people of short stature. An equal mix of “high” and “low” is required in new construction; however, a dispersion of multiple height drinking fountains is unlikely to be

found in many existing older facilities. Older model drinking fountains may satisfy the “high” requirement but usually have controls and water spouts that are above the reach of many people. Most people using wheelchairs and scooters can use drinking fountains if the spout is no more than 36 inches above the floor with controls located toward the front of the unit. An accessible fountain preferably has a knee space to allow someone using a wheelchair to pull up under the basin and better reach the spout and controls.

wall-hung cooler  
easy to use when  
lower than 36”

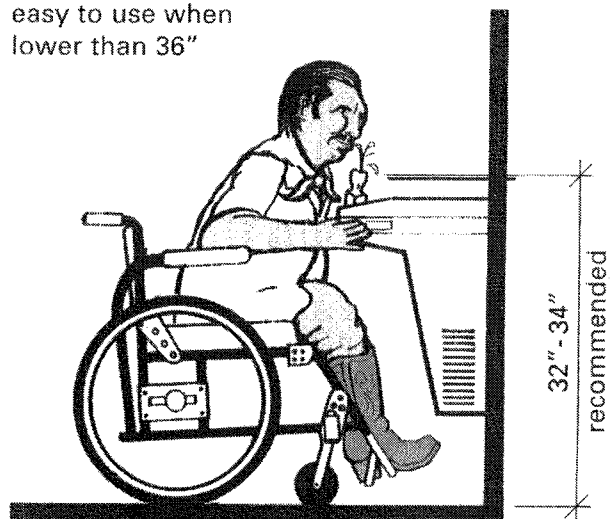

**Accessible Water Cooler With  
Knee Space**

If existing fountains are too high, paper cup dispensers mounted no more than 48 inches above the floor provide a good temporary solution. Be sure, however, to relocate any adjacent furniture or planters that may interfere with a person using a wheelchair from getting close to the fountain. If drinking fountains have foot-operated controls, a cup dispenser still should be installed and staff should be prepared to assist as necessary. Portable water containers can also be provided in the manner discussed previously to compensate for inaccessible drinking fountains.

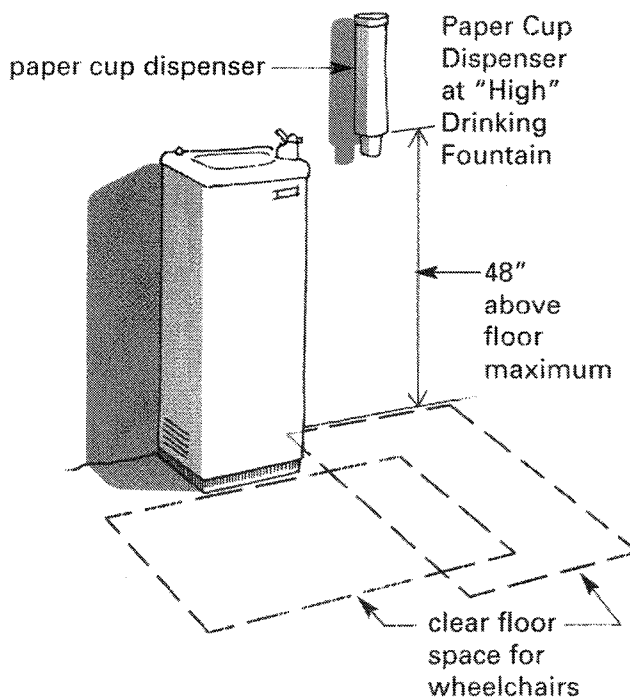

## SHELTER

Shelter from rain, intense sun exposure, and cold are a good idea at any outdoor event. Many people with disabilities and older adults are sensitive to heat and/or cold and will appreciate this added feature. If temperatures during

## Accessible Water Cooler with Knee Space

the event are extreme, i.e., above 80 degrees or below 50, make arrangements for access into facilities with more moderate temperatures. For large outdoor events, plan for at least one accessible outdoor shelter in each

major activity area, particularly if access into adjacent buildings is not possible.

Make existing shelters accessible or new accessible temporary shelters can be economically created using tents or tarps. Temporary shelters should be located on level ground adjacent to an accessible route. Consider locating shelters close to existing water fountains or, in areas where this may not be possible, provide water in portable containers.

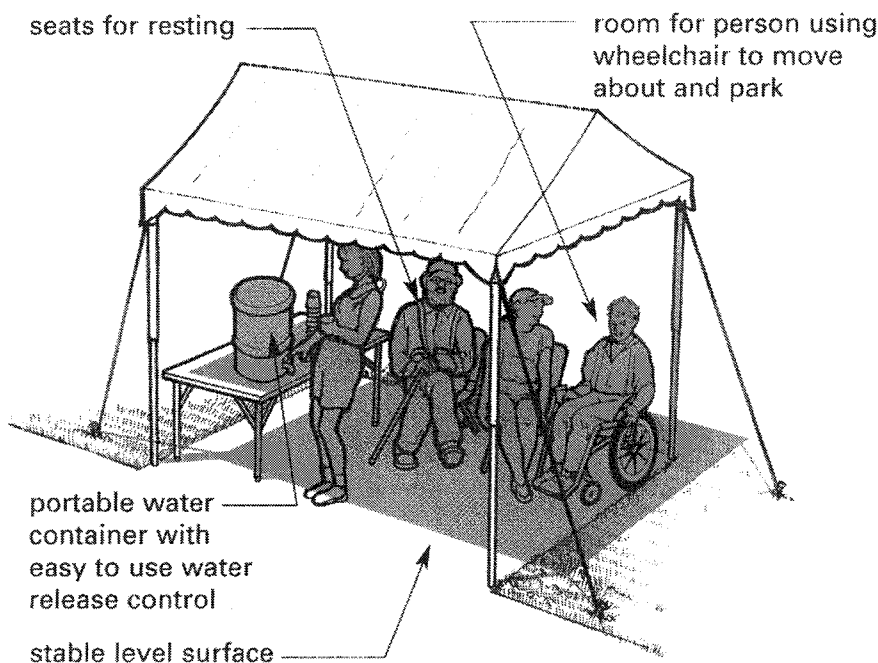

## Shelter for Rest and Shade with Drinking Water

## TELEPHONES

Most people who use wheelchairs or scooters can use pay telephones if there is sufficient floor space to position themselves parallel to the telephone unit to make a side reach to the highest operable part of the phone — which should be no higher than 54 inches maximum from the floor, i.e., 54 inches to the coin slot, coin release lever, or handset and the cord for the handset must be at least 29 inches long. For courtesy telephones to be usable, especially if equipped with an angled keypad (as opposed to a keypad flush on the wall), the telephone should be positioned no higher than 44 inches above the floor. However, in older facilities, most pay telephones likely are mounted too high, courtesy telephones are located on high counters, and any existing accessible telephones often are located in areas remote to the event.

Physical accessibility to telephones is not the only consideration. Communication barriers must be overcome. Telephones may lack volume controls that are a help to people with partial hearing who require sound amplification. Many facilities lack text telephones, known as TTYs or TDDs, that are used to transmit typed messages across a standard telephone network by people who find it difficult to or cannot communicate orally.

Text telephones are recommended at larger events because, with big crowds, there will be a higher number of participants who will need to make use of such a service. If the facility itself

does not have a text telephone, consider renting a portable TTY and train a staff member in its use. All event staff should know its availability and location.

If pay telephones are on the site and none are accessible, a courtesy phone may be provided for use by people with disabilities. For a large event, place the courtesy telephone in a centrally located area such as the main information desk or booth and add signage indicating its availability. Similar signage should be located at each bank of inaccessible pay phones directing the user to the courtesy phone(s).



**Portable TTY**

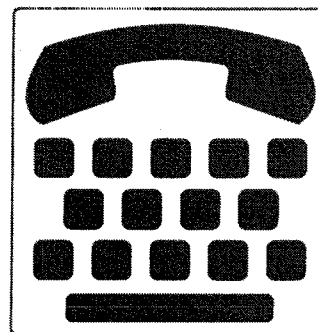

**International  
TTY Symbol**

An economical solution to inaccessible telephones is to create one or more accessible telephone stations, which may be located in monitored areas. A standard telephone may be placed on a surface with knee space below in an easy-to-approach location connected to an accessible route. If possible, select a telephone that includes volume control. It also is preferred that the station include an electrical receptacle

for use by people who may carry their own portable TTY units or for those provided by the event. An additional provision that increases the ease with which event participants find amenities is to indicate the availability and location of accessible telephones and TTYs on event maps and information brochures, especially if accessible telephones are not available in all activity areas.

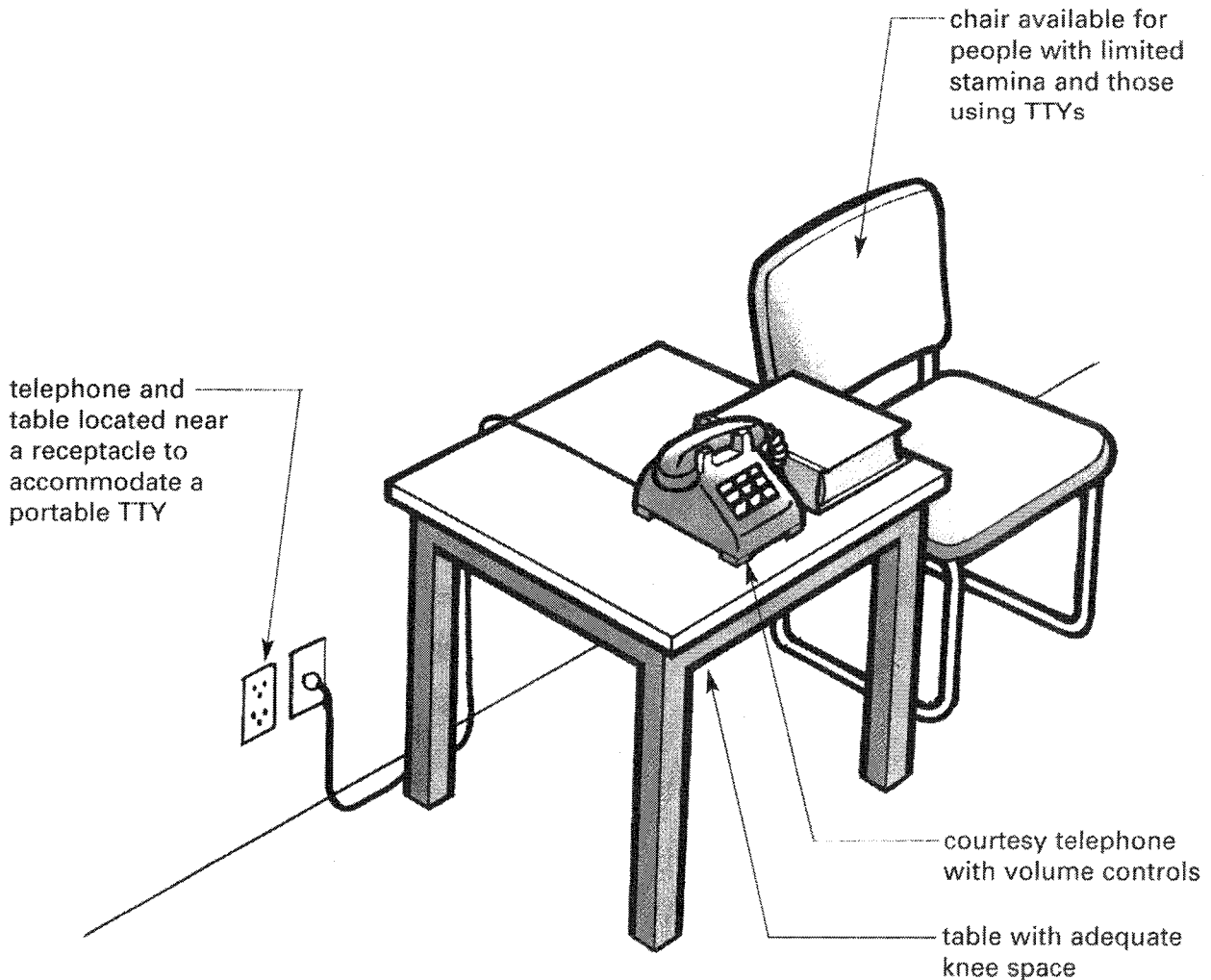

**Accessible Telephone Station**

# CHAPTER **SIX** | Resources

## LOCATING RESOURCES

Assessing issues of accessibility for everyone is a first step in planning an event. The previous chapters have provided ideas and methods to make facilities accessible. This chapter can help you find the necessary resources to finish the task.

There are many individuals and organizations that are experienced with the ADA and other issues of accessibility. If the event you are planning is being held in your own city, consult the telephone book for listings under organizations, associations, and government agencies dealing with disabilities. Often, one or two contacts can provide many additional sources of assistance, as private and public groups often tend to work together on projects and issues. Consumer groups of people with disabilities can be especially valuable in providing advice on transportation services, accessible hotels, restaurants and places of entertainment, suppliers of services, devices and equipment, and sources of volunteers. If you are planning the event for another city, a little more detective work may be required.

For an excellent source of information, contact the Disability Business and Technical Assistance Center (DBTAC) in the region where the event is to take place. See page 100 for a listing of all ten regional DBTACs. These offices can be accessed by calling the nationwide toll free number to reach the regional office that serves the state you are calling from (1-800-949-4232 v/tty).

You can also secure necessary products and services by contacting:

- individuals with disabilities who work with the various local disability organizations;
- federal and state government agencies for publications and training;
- architects, designers, or organizations who have experience in the interpretation and application of accessibility codes and standards;
- professionals in the construction industry with experience in architectural modifications for accessibility; and
- event officials/managers who have successfully addressed accessibility issues for previous events.

Through a network of local offices, chapters, and members, you should be able to locate the services you require plus receive direct consumer input on a variety of accessibility issues relevant to your event site.

Unless you have a complete library of catalogs at your fingertips, locating accessible products and equipment can be frustrating. To assist you, there is a national website of adaptive equipment for people with all types of disabilities. Funded by the National Institute on Disability and Rehabilitation research (NIDRR), **assistivetechnet.net** contains thousands of listings and is continuously updated.

## CHAPTER 6

For more information or to access this web site, contact:

### **ASSISTIVETECH.NET**

**Center for Assistive Technology & Environmental Access**

**Georgia Institute of Technology**

490 Tenth Street

Atlanta, Georgia 30318

800-726-9119 (toll free)

404-894-0240 (phone)

404-894-9320 (fax)

[www.assistivetech.net](http://www.assistivetech.net)

## **LOCATING RESOURCES**

### **FEDERAL AGENCIES**

Federal agencies provide information, free publications and answers questions about the ADA.

**Department of Justice (DOJ)**

**Civil Rights Division, Disability Rights Section**

**P.O. Box 66738**

**Washington, DC 20035-6738.**

**(800) 514-0301 (V)**

**(800) 514-0383 (TTY)**

**(202) 307-1198 (Fax)**

[www.usdoj.gov/crt/ada/adahom1.htm](http://www.usdoj.gov/crt/ada/adahom1.htm)

Check the reference desk at your local library for the following documents (ask for the **ADA Information File**) or contact the DOJ directly at the above numbers. DOJ also offers a free fax service and additional free publications.

- Public Law 101-336 (The Americans with Disabilities Act of 1990 as enacted by Congress)
- Title I: Employment

- Title II: State and Local Governments
- Title III: Public Accommodations and Commercial Facilities
- Title I Technical Assistance Manual and Resource Directory
- Title II Technical Assistance Manual (1993 edition)
- Title III Technical Assistance Manual (1993 edition)
- ADA Standards for Accessible Design (The Standards)

**U.S. Department of Education National Institute on Disability and Rehabilitation Research (NIDRR), U.S. Department of Education**

This organization funds a network of ten (10) regional **Disability and Business Technical Assistance Centers (DBTACs)** that provide information, training, and technical assistance to businesses and agencies covered by the ADA and to people with disabilities who have rights under the Act. Each center may be contacted directly or you may be automatically connected to the center serving your region by calling: **1.800.949.4232 - Voice/TTY**

- **Region 1 (CT, ME, MA, NH, RI, VT)**  
**New England DBTAC**  
**Adaptive Environments Center, Inc.**  
**374 Congress Street, Suite 301**  
**Boston, MA 02210**  
**(617) 695-0085 (V/TTY)**  
**(617) 482-8099 (Fax)**  
**[adaptive@adaptenv.org](mailto:adaptive@adaptenv.org)**  
**<http://www.adaptenv.org>**
- **Region 2 (NJ, NY, PR, VI)**  
**Northeast DBTAC**  
**Cornell University**



- Training & Management Division  
 107 ILR Extension Building  
 Ithaca, NY 14853-3901  
 607-255-8348  
 607-255-2763 (Fax)  
<http://www.nedbtac.org>  
[ah45@cornell.edu](mailto:ah45@cornell.edu)
- **Region 3 (DE, DC, MD, PA, VA, WV)**  
 Mid-Atlantic DBTAC  
 TransCen, Inc.  
 451 Hungerford Drive, Suite 607  
 Rockville, MD 20850  
 (301) 217-0124 (V/TTY)  
 (301) 217-0754 (Fax)  
[adainfo@transcen.org](mailto:adainfo@transcen.org)  
<http://www.adainfo.org>
  - **Region 4 (AL, FL, GA, KY, NC, SC, MS, TN)**  
 Southeast DBTAC  
 Center for Assistive Technology and  
 Environmental Access at Georgia Tech  
 490 Tenth Street  
 Atlanta, GA 30318  
 (404) 385-0636 (V/TTY)  
 (404) 385-0641 (Fax)  
[se-dbtac@mindspring.com](mailto:se-dbtac@mindspring.com)  
<http://www.sedbtac.org>
  - **Region 5 (IL, IN, MI, MN, OH, WI)**  
 Great Lakes DBTAC  
 University of Illinois/Chicago  
 Department on Disability & Human  
 Development  
 1640 West Roosevelt Road  
 Chicago, IL 60608  
 (312) 413-1407 (V/TTY)  
 (312) 413-1856 (Fax)  
[gldbtac@uic.edu](mailto:gldbtac@uic.edu)  
<http://www.adagreatlakes.org>
  - **Region 6 (AR, LA, NM, OK, TX)**  
 Southwest DBTAC  
 Independent Living Research Utilization  
 2323 South Shepherd Boulevard,  
 Suite 1000  
 Houston, TX 77019  
 (713) 520-0232 (V/TTY)  
 (713) 520-5785 (Fax)  
[ilru@ilru.org](mailto:ilru@ilru.org)  
<http://www.ilru.org/dbtac>
  - **Region 7 (IA, KS, MO, NE)**  
 Great Plains DBTAC  
 ADA Project  
 University of Missouri/Columbia  
 100 Corporate Lake Drive  
 Columbia, MO 65203  
 (573) 882-3600 (V/TTY)  
 (573) 884-4925 (Fax)  
[adalh@showme.missouri.edu](mailto:adalh@showme.missouri.edu)  
<http://www.adaproject.org>
  - **Region 8 (CO, MT, ND, SD, UT, WY)**  
 Rocky Mountain DBTAC  
 Meeting the Challenge, Inc.  
 3630 Sinton Road, Suite 103  
 Colorado Springs, CO 80907  
 (719) 444-0268 (V/TTY)  
 (719) 444-0269 (Fax)  
[RegionVIII@mtc-inc.com](mailto:RegionVIII@mtc-inc.com)  
<http://www.ada-infonet.org>
  - **Region 9 (AZ, CA, HI, NV, Pacific Basin)**  
 Pacific DBTAC  
 California Public Health Institute  
 2168 Shattuck Avenue, Suite 301  
 Berkeley, CA 94704-1307  
 (510) 848-2980 (V)  
 (510) 848-1840 (TTY)  
 (510) 848-1981 (Fax)  
[adatech@pdbtac.com](mailto:adatech@pdbtac.com)  
<http://www.pacdbtac.org>
  - **Region 10 (AK, ID, OR, WA)**  
 Northwest DBTAC  
 Northwest ADA/IT Center  
 P.O. Box 574  
 Portland, Oregon 97207-0574  
 (503) 494-4001  
<http://www.nwada.org>

## STATE AGENCIES

Although the titles may vary, each state has an individual designated to act in the capacity of an **ADA Coordinator**. This position may be through the state's Department of Administration or Department of Human Resources. Each state also has its own protection and advocacy service system to help educate and protect people with disabilities about their rights under the law. Contact the National Association for Protection and Advocacy Systems (NAPAS) for the protection and advocacy agency in your area.

### NAPAS

900 Second Street NE, Suite 211

Washington, D.C. 20002

202-408-9514

202-408-9521 (TTY)

202-408-9520 (fax)

[www.protectionandadvocacy.com](http://www.protectionandadvocacy.com)

[napas@earthlink.net](mailto:napas@earthlink.net)

## CENTERS FOR INDEPENDENT LIVING

There are approximately 400 Independent Living Centers throughout the U.S. and Puerto Rico, with at least one located within each state. These Centers can be a valuable source for products and services available in or around the city where your event is being held. Independent Living Research Utilization (ILRU) in Houston, TX has an online directory of Centers at <http://www.ilru.org/jump1.htm>.

### ILRU Program

2323 South Shepherd, Suite 1000,

Houston, Texas 77019

(713)-520-0232 [voice]

(713)-520-5136 [TTY]

(713)-520-5785 [fax]

[ilru@ilru.org](mailto:ilru@ilru.org)

## NATIONAL ORGANIZATIONS

Many national organizations provide information in a variety of mediums about specific disabilities and appropriate auxiliary aids and services. In addition many can identify regional/local technical assistance and training resources.

For a detailed listing, consult the Directory of **National Information Sources on Disabilities** published in 1999 by the National Rehabilitation Information Center (NARIC) under contract to the National Institute on Disability and Rehabilitation Research (NIDRR), Office of Special Education and Rehabilitative Services, U.S. Department of Education. This publication aids in the location, identification, and description of all organizations supplying disability-related information, referral, and direct services on a nationwide basis. Call **1.800.346.2742** for more information.

## BOOKS/ARTICLES

- **ADA Title III Fact Sheet Series:**
  - #1 Who Has Obligations Under Title III?
  - #2 Providing Effective Communications
  - #3 Communicating with People with Disabilities
  - #4 Alternatives to Barrier Removal

Order through your regional DBTAC office, 800.949.4232. (voice/tty)

- *A Guide to Planning Accessible Meetings*, J.I. Kailes and D. Jones (1993). ILRU Program, 2323 S. Shepherd, Suite 1000, Houston, TX 77019, 713.520.0232 (Voice); 713.520.5136 (TTY).
- *Accommodating All Guests: The Americans with Disabilities Act of 1990 and the Lodging Industry*, J.P. Salmon (1992). American Hotel & Motel Association, 1201 New York Avenue, NW, Washington, DC 20005, 202.289.3100 (Voice).
- *Means ADA Compliance Pricing Guide* (1994). R.S. Means Company, Inc., 100 Construction Plaza, P.O. Box 800, Kingston, MA 02364-0800, 800.448.8182 (Voice); 800.632.6701 (Fax).
- "Set-Ups for Speeches: A Guide to Optimum Use of ALS and Interpreters," W.B. Cutler (1991). SHHH. Request in writing: Attn: Editor, Self Help for Hard of Hearing People, 7910 Woodmont Avenue, Suite 1200, Bethesda, MD 20814.
- *The Planner's Guide to Barrier Free Meetings* (1980). Barrier Free Environments, Inc., P.O. Box 30634, Raleigh, NC 27622, 919.782.7823 (Voice/TTY); 919.787.1984 (Fax).
- *UFAS Retrofit Guide: Accessibility Modifications for Existing Buildings* (1993). Van Nostrand Reinhold, 7525 Empire Drive, Florence, KY 41042, 800.225.5945 (Voice); 606.525.7778 (Fax).
- *Volunteers Who Produce Books*. Library of Congress, National Library Service for the Blind and Physically Handicapped, 1291 Taylor Street, NW, Washington, DC 20542, 800.424.8567 (Voice); 202.707.0744 (TTY); 202.707.0712 (Fax).
- "What Is Real-Time Captioning and How Can I Use It?" L. Miller (1989). SHHH. Request in writing: Attn: Editor, Self Help for Hard of Hearing People, 7910 Woodmont Avenue, Suite 1200, Bethesda, MD 20814.

**Checklists:**

- *ADA Compliance Guidebook: A Checklist for Your Building* (1991). BOMA International, P.O. Box 79330, Baltimore, MD 21279-0330, 800.426.6292 (Voice); 301.843.0159 (Fax).
- *Checklist for Existing Facilities (Version 2.1)* 1995. Order through your regional DBTAC office, 800.949.4232. (voice/tty)
- *Design for Accessibility: An Arts Administrator's Guide* (1994). National Assembly of State Arts Agencies, 1010 Vermont Avenue, Suite 920, Washington, DC 20005, 202.347.6352 (Voice).
- *The Accessibility Checklist: An Evaluation System for Buildings and Outdoor Settings* (1993). MIG Communications, 1802 Fifth Street, Berkeley, CA 94710, 510.845.0953 (Voice).

